

THE CITY OF EDMONTON

**PROJECT AGREEMENT
VALLEY LINE WEST LRT**

Schedule 5 – D&C Performance Requirements

Part 3: Civil

TABLE OF CONTENTS

PART 3 : CIVIL	3-1
SECTION 3-1 - TRACK.....	3-1
3-1.1 Design Basis and Criteria	3-1
3-1.2 Not Used	3-8
3-1.3 Functional and Technical Requirements	3-8
3-1.4 Trackway Integration	3-12
SECTION 3-2 – ROADWAYS, SIDEWALKS AND SHARED USE PATHS.....	3-14
3-2.1 Scope.....	3-14
3-2.2 Design Basis and Criteria	3-14
3-2.3 Safety Audit	3-17
3-2.4 Geometric Design	3-18
3-2.5 Pavement Design Requirements	3-21
3-2.6 Bus Stops	3-25
3-2.7 Bicycle Parking	3-31
3-2.8 Signing, Delineation and Pavement Markings	3-31
3-2.9 Road Appurtenances	3-32
3-2.10 Restoration of Infrastructure	3-32
3-2.11 Area Specific Requirements	3-33
SECTION 3-3 WEST EDMONTON MALL TRANSIT CENTRE.....	3-69
3-3.1 Scope.....	3-69
3-3.2 Design Basis and Criteria	3-69
3-3.3 Design Specific Requirements.....	3-72
SECTION 3-4 LEWIS FARMS PARK AND RIDE.....	3-76
3-4.1 Scope.....	3-76
3-4.2 Design Basis and Criteria	3-76
3-4.3 Design Specific Requirements.....	3-77
SECTION 3-5 STORMWATER MANAGEMENT	3-83
3-5.1 Scope.....	3-83
3-5.2 Reference Standards	3-83
3-5.3 Design Criteria	3-83
3-5.4 Minor Drainage	3-86
3-5.5 Major Drainage	3-88
3-5.6 Stormwater Management – Specific Facilities	3-91
3-5.7 Sewer Relocations	3-95
3-5.8 New Sewer Infrastructure	3-102

SECTION 3-6 UTILITIES	3-106
3-6.1 General	3-106
3-6.2 Access to and Protection, Abandonment and Removal of Utility Infrastructure	3-109
3-6.3 Utility Infrastructure Repairs	3-109
3-6.4 Pipeline Crossing Records	3-110
SECTION 3-7 STREET LIGHTING REQUIREMENTS	3-111
3-7.1 Scope.....	3-111
3-7.2 Design Basis and Criteria	3-111
3-7.3 Design Specific Requirements.....	3-111

TABLES AND FIGURES

TABLE 3-2.2.1 ROADWAYS POSTED SPEED (MAIN ALIGNMENT)	3-15
TABLE 3-2.2.2 ROADWAYS POSTED SPEED (CROSS STREETS)	3-15
TABLE 3-2.5.1 MINIMUM PAVEMENT STRUCTURES (MAIN ALIGNMENT).....	3-21
TABLE 3-2.5.2 MINIMUM PAVEMENT STRUCTURES (ANCILLARY LOCATIONS)	3-22
TABLE 3-2.5.3 MINIMUM PAVEMENT STRUCTURES (ALLEYS AND TURNAROUNDS)	3-23
TABLE 3-2.6 BUS STOP REQUIREMENTS	3-27
TABLE 3-2.7 BICYCLE RACKS REQUIRED AT EACH STOP/STATION	3-31
TABLE 3-2.11.1 ROAD CLOSURE AND ACCESS CLOSURE BYLAW EFFECTIVE DATES.....	3-34
TABLE 3-2.11.3 87 AVENUE (EXISTING ANTHONY HENDAY DRIVE BRIDGE TO EAST OF 182 STREET) SUP/SIDEWALK REQUIREMENTS.....	3-38
TABLE 3-2.11.4 87 AVENUE (EAST OF 182 STREET TO 159 STREET) SUP/SIDEWALK REQUIREMENTS.....	3-41
TABLE 3-2.11.5 MEADOWLARK ROAD AND 156 STREET (87 AVENUE TO STONY PLAIN ROAD) SUP/SIDEWALK REQUIREMENTS	3-47
TABLE 3-2.11.6 STONY PLAIN ROAD (156 STREET TO 149 STREET) SUP/SIDEWALK REQUIREMENTS.....	3-51
TABLE 3-2.11.7 STONY PLAIN ROAD (149 STREET TO 139 STREET) SUP/SIDEWALK REQUIREMENTS.....	3-53
TABLE 3-2.11.8 STONY PLAIN ROAD (139 STREET TO 121 STREET) SUP/SIDEWALK REQUIREMENTS.....	3-56
TABLE 3-2.11.9 104 AVENUE (121 STREET TO 105 STREET) SUP/SIDEWALK REQUIREMENTS.....	3-62
TABLE 3-2.11.10 107 STREET (104 AVENUE TO 102 AVENUE) SUP/SIDEWALK REQUIREMENTS.....	3-64

TABLE 3-2.11.11 102 AVENUE (107 STREET TO 102 STREET) SUP/SIDEWALK REQUIREMENTS.....	3-66
FIGURE 3-3.2.3-1 CITY OF EDMONTON BUS PROFILE	3-70
FIGURE 3-3.2.3-2 CITY OF EDMONTON ARTICULATED BUS PROFILE.....	3-71
FIGURE 3-3.2.3-3 CITY OF EDMONTON ELECTRIC BUS PROFILE	3-71
TABLE 3-4.3.1 MINIMUM PAVEMENT STRUCTURES (LEWIS FARMS PARK AND RIDE)	3-82
TABLE 3-5.7.1 SEWER MAIN REMOVAL AND REPLACEMENT WITH CASING LOCATIONS	3-95
TABLE 3-5.7.2 SEWER SERVICES REMOVAL AND REPLACEMENT WITH CASING LOCATIONS.....	3-96
TABLE 3-5.7.3 MINIMUM CASING PIPE SIZING	3-98
TABLE 3-5.7.4 SEWER SERVICES IN PARTIALLY ACQUIRED LANDS – SINGLE FAMILY AND DUPLEX	3-101
TABLE 3-5.7.5 SEWER SERVICES IN PARTIALLY ACQUIRED LANDS- COMMERCIAL AND MULTI-FAMILY	3-101

APPENDICES

APPENDIX 5-3A ACCESS AND ROAD CLOSURE DRAWINGS

APPENDIX 5-3B 102 AVENUE GRADING CONSTRAINTS DRAWINGS

PART 3: CIVIL

Section 3-1 - TRACK

3-1.1 DESIGN BASIS AND CRITERIA

3-1.1.1 Reference Standards

- A. Without limiting Section 1-1.7 [*Reference Documents*] of this Schedule, and except as otherwise specified herein, develop and implement design standards for the Track alignment, Track and all associated infrastructure (the "**Track Design Criteria**") based upon with the following guidance, standards and regulations, as adjusted to accommodate all On-track Vehicles:
1. TCRP Report 155 – Track Design Handbook for Light Rail Transit, Second Edition;
 2. AREMA Manual for Railway Engineering;
 3. AREMA Portfolio of Trackwork Plans;
 4. EN 13232: Track - Switches and crossings;
 5. EN 14811 – Special Purpose Rail; and
 6. EN 13674-4 – Part 3: Check Rail.
- B. The Track Design Criteria shall provide all design criteria limits (i.e. minimum and maximums) and shall account for all factors affecting the safe and efficient operation of the Infrastructure.
- C. In the event of any conflict, ambiguity or inconsistency between or among the requirements of Section 3-1.1.1A of this Schedule, the requirements of TCRP Report 155 shall prevail.
- D. All track material, special trackwork and practices described herein shall govern the design of track and include the required interfacing of trackwork with other elements of the Infrastructure such as, but not limited to, trackway, bridges, track slabs, transition slabs, electrification system, signal system, drainage.
- E. Submit Track Design Criteria 60 days after the Effective Date.
- F. Submit Design Drawings and construction specifications for trackwork and related track materials addressing interface requirements as well as other trackwork requirements. Include this information in the Track Design Report and provide all the key trackwork design aspects.
- G. For any trackwork component or assembly to be accepted for inclusion in new construction, it shall be based on existing, service proven technology and have a record of performance acceptable to the City. All trackwork components shall be demonstrated to be capable of withstanding the climate conditions as specified in Section 1-2.1.10 [*Edmonton Climatic Requirements*] of this Schedule. Any trackwork component that is not service proven shall be submitted to the City for acceptance.

3-1.1.2 Track Alignment

- A. Using the Track Design Criteria as a basis and complying with Section 1-1.2.1 [*Infrastructure Alignment and Design Constraints*] of this Schedule, perform a Track alignment optimization study, as part of the design development process, to determine the optimal Track alignment necessary to ensure the safe and efficient operation of the Infrastructure (the "**Track Optimization Study**"). The Track Optimization Study shall be submitted to the City with the first Interim Design submission and revised and re-submitted with each of the second Interim Design and Final Design submissions for

the Mainline Track Alignment as described in Appendix 4B [*Project Specific Submission Requirements*]. Demonstrate how the Track alignment is optimized for the Infrastructure, including:

1. performance characteristics of the Stage 1 LRVs, including acceleration and braking capability;
 2. all potential Train configurations for normal operations and emergency towing events, including LRV dimensions and bogie spacing;
 3. Rail/wheel interface, including characteristics of the rail and wheel profiles for the On-track Vehicles;
 4. the effect of different operating speeds, up to and including the Maximum Design Speed;
 5. LRT Corridor constraints, including Station and Stop locations, LRV Platform Interface, available stopping distance (including results from stopping sight distance study), horizontal curvature, spiral transition, superelevation, grade and overlapping condition of horizontal curve with vertical curve and steep grade;
 6. interfaces between the Track and adjacent structures, including the effect of Special Trackwork anti-creep devices, sliding rail joints, rail lubricators and rail restraining devices in areas where differential structural movement is anticipated;
 7. the passenger ride comfort requirements identified in TCRP Report 155;
 8. track design speed in accordance with Section 3-1.1.3 [*Design Speeds*] of this Schedule; and
 9. track structure limits and transition requirements.
- B. Optimize the Track alignment in accordance with the results of the Track Optimization Study, subject to the following requirements:
1. Passengers shall not be subjected to excessive accelerations, vibrations, or shocks, as defined in TCRP Report 155, *Section 2.4.6 Light Rail Vehicle Ride Quality and 3.2.4 Curvature, Speed, and Superelevation—Theory and Basis of Criteria*, when the Train is travelling at the Maximum Design Speed; and
 2. lateral acceleration and jerk rate due to curvature of Track shall not exceed the following acceleration of gravity values:
 - a. Ballasted Track: 0.1 g maximum lateral acceleration;
 - b. Direct Fixation Track and Embedded Track: 0.15 g maximum lateral acceleration; and
 - c. the maximum jerk rate for any spiral length of Mainline Track shall not exceed 0.03 g/sec.

3-1.1.3 Design Speeds

- A. Design for the Maximum Design Speed for each section of the alignment up to 80 km/h and include all relevant calculations with the applicable Final Design package.
- B. For each section of the alignment include all relevant calculations with the applicable first Interim Design, second Interim Design, and Final Design package for Maximum Operating Speed and Maximum Design Speed.
- C. Yard track shall have a design speed of no less than 15 km/h.

3-1.1.4 Track General

3-1.1.4.1 Standard Trackwork Components

- A. All running rails for LRT tracks shall be new and of 115RE rail section. All rail shall be fully head hardened having a Brinell hardness of 365 to 380 BHN.
- B. Bolted rail joints shall only be used in locations where insulation joints (IJ) are used or in Yard track.
- C. Zero-gap joints are permitted in Special Trackwork as indicated in Section 3-1.3.6 [*Turnout Standards and Geometry*] of this Schedule.
- D. Continuous Welded Rail (CWR) requires rails to be joined together by welding. Rail shall be welded into the longest strings practical by means of Electric Flash-Butt (EFB) welding. The EFB equipment shall be programmed appropriately for the specific rail chemistry being welded.
- E. Thermite welds may be used to join rail strings and for joining rails in situations where EFB welding is not practical.
- F. Wherever it is necessary to electrically isolate contiguous rails from each other in order to comply with track signalling or Traction Power criteria, insulated rail joints shall be used.

3-1.1.4.2 Track Configuration

- A. All Mainline Track shall consist of two sets of nominally parallel Tracks designed for revenue service, right hand running operation with a nominal length Train of 90m and shall include provision for the impact of emergency towing.
- B. The track is a structure in which the weight of the running rail, type and size of track fastener, depth of foundation slab, and elastomer stiffness are all interrelated. The characteristics of the track system provided in the Design must not be changed without submitting the change to the City for review pursuant to Schedule 2 [*Submittal Review Procedure*] and considering the impact on: public safety, track stability, track stiffness, noise and vibration, electrical insulating characteristics, track maintainability and track life cycle cost.
- C. Design of the Trackway and all other infrastructure shall meet the requirements of Section 1-2.1.8 [*LRV Accommodation*] of this Schedule.
- D. The Trackway design must address the following:
 - 1. stray current in accordance with Section 1-2.4 [*Stray Current and Corrosion Control Program*] of this Schedule;
 - 2. noise in accordance with Section 1-2.1.5 [*Noise Control*] of this Schedule; and
 - 3. vibration in accordance with Section 1-2.1.7 [*Vibration Control*] of this Schedule.
- E. Provide shop drawings and design reports demonstrating that the products used within the design accommodate noise and vibration requirements
- F. The Trackway shall interface with civil structures provided to manage surface water runoff within and/or adjacent to the Trackway.
 - 1. The trackwork design shall accommodate this interface without compromising track strength or stability.

2. In Embedded Track designated areas, where the Trackway is higher than the adjacent road curb and emergency vehicle access is required in accordance with Section 3-2.4.6 [*Curb and Gutter*] of this Schedule, a maximum slope of 6% may be provided from the outside of the rail towards the adjacent road curb, except:

- a. in areas where the top of concrete within the entire Trackway must be flush with top of rail, as specified in Schedule 5, Section 2-4 [*Urban Realm*].

- G. In locations such as below grade utility crossings, coordination with the Utility Company shall be undertaken to develop Trackway solutions to protect/accommodate the utility installation.

3-1.1.4.3 Track Gauge

- A. All Track shall be a standard gauge of 1435 mm, measured at a point 16 mm below top of the running rail.

3-1.1.4.4 Track Superelevation

- A. Provide Track superelevation on curved sections of the alignment where required to ensure compliance with the passenger ride comfort and operational safety requirements of this Schedule.
- B. Track superelevation shall not be permitted on any Track sections that include turnouts, crossovers or diamond crossings, nor on Yard Track.

3-1.1.4.5 Horizontal Curves

- A. The minimum radius of all curves on Mainline Track shall accommodate all On-track Vehicles.
- B. The minimum radius curves on the Mainline Track shall be 35 m.
- C. The minimum radius curves on Yard Track shall be 25 m.
- D. The minimum length of tangent between reverse curves and curves in the same direction shall accommodate all On-track Vehicles.
- E. The minimum spiral length for all Mainline Track shall be no less than that required to accommodate the bogie spacing of any Train configuration.
- F. Horizontal curves are not permitted through Stop or Station platform limits.
- G. Tangent track shall extend beyond the platform limits as long as possible, at a minimum length required to prevent the Dynamic Envelope of all On-Track Vehicles from intercepting the platform, while maintaining the gap tolerances between the stopped train and platform edge, but such extension shall be no shorter than 9.5m.

3-1.1.4.6 Vertical Curves

- A. All vertical curves shall be parabolic, with a minimum rate of change (K value), as required to accommodate all Trains.
- B. Changes in grade shall not be permitted on any Track sections that include switches, crossovers or at Stop or Station locations.

3-1.1.5 Trackway

3-1.1.5.1 General

- A. Rail deflection shall not exceed the allowable rail deflection as specified in TCRP Report 155.

- B. Rail break gap shall not exceed the allowable rail break gap as specified in TCRP Report 155, and shall not be greater than 50 mm.
- C. Design the Trackway based on the neutral temperature applicable to each section of the alignment.
- D. Design all Trackway systems to address all the technical and interface requirements as well as the environmental conditions described in Section 1-2.1.10 [*Edmonton Climatic Requirements*] of this Schedule and:
 - 1. the environmental conditions related to winter conditions including resistance to the effects of road gritting, heavy salt and de-icing chemicals, cold temperatures, heavy snow falls, icing conditions, the high potential for frost heaving conditions and design solutions that are not susceptible to damage from snow plowing. One of the key technical issues is designing the embedded trackway for use by rubber-tired traffic.
- E. The Trackway shall be constructed within the suggested construction tolerances identified in TCRP Report 155 section 4.2.6.3, or tighter, as determined by Project Co.
- F. All Trackway, including Mainline Track, Yard Track and Shop Track shall be designed and constructed to minimize settlement in accordance with the suggested maintenance tolerances identified in TCRP Report 155, section 3.8.1.2.
- G. The Trackway shall be designed to minimize differential settlement in order to maintain the ride quality in accordance with 3-1-1.2 [*Track Alignment*] of this Schedule.
- H. Maximum vertical settlement of the Trackway in embedded/DF track: To be determined based on geotechnical recommendations in order to accommodate longitudinal differential settlement, but no more than 25mm total settlement over the Design Service Life of the Trackway.
- I. Longitudinal differential settlement of the Trackway shall be no greater than 15 mm (5/8") measured over 9.4m (31').

3-1.1.5.2 Embedded Track

- A. Embedded track shall be designed and constructed to provide a suitable running surface for rubber-tired traffic (including snow ploughs in operation), meeting corrosion control requirements, providing a suitable walking surface for pedestrian crossing movements and presenting a clean and aesthetically appropriate appearance for location specific form and function.
- B. Project Co shall tie-in and transition the embedded track design to the existing embedded track construction completed by Others as part of Valley Line LRT Stage 1, including any modifications to the existing Track infrastructure necessary to provide a seamless transition in accordance with all requirements in this Schedule.
- C. Embedded track is to be provided, at minimum, in the following locations:
 - 1. at each Grade Crossing except:
 - a. at Grade Crossings from the western Project limit of the alignment to the west approach of the 87 Avenue Elevated Guideway Ramp east of 182 Street (except for any Integrally Coloured Concrete crosswalks within a PPZ), precast panels matching the finish and colour of any adjacent cast-in-place concrete Trackway may be used to provide a flush, walkable/driveable surface;
 - 2. through all Stops, including the zones delineated by crosswalks and intersections adjacent to the applicable Stop;

3. from the eastern Project limit to the east approach of the 87 Avenue Elevated Guideway Ramp west of 163 Street using Integrally Coloured Concrete in accordance with Section 2-4.2E [*Streetscape*] of this Schedule, except:
 - a. at switch locations, precast Integrally Coloured Concrete panels matching the finish and colour of the adjacent cast-in-place Integrally Coloured Concrete Trackway may be used to provide a flush, walkable/driveable surface;
 4. for a distance of 50m in the TUC, centred longitudinally on the gore between the future eastbound to southbound and westbound to southbound ramps onto Anthony Henday Drive, as shown in Figures 5-1A-02 of Appendix 5-1A [*Project Description Drawings*] in Part 1 [*General*] and in accordance with Alberta Transportation's Hwy 216 / Anthony Henday Drive Functional Planning Study 2008;
 5. for a distance of 10m east from the east curblineline of the ramp to and from northbound Anthony Henday Drive to accommodate the crossing of a future second northbound to eastbound right turn lane; and
 6. within the Maintenance and Storage Facilities as described in Section 3-1.1.5.5 [*Shop Tracks*] and Section 3-1.1.5.6 [*Yard and Yard Tracks*] of this Schedule.
- D. Embedded track shall be provided with a flangeway on the gauge side of the rail plus field side relief to accommodate all On-Track Vehicles plus maintenance considerations, including rail and wheel wear, and in accordance with TCRP Report 155.
- E. Embedded track shall be designed to minimize snow and ice build up within the flangeway by providing a centre swale between the rails extending from the bottom of the flangeway with the low point along the centre of the track, except:
1. at Grade Crossings, where a centre swale would create a tripping hazard; and
 2. in areas requiring the top of concrete between the rails to match the elevation of the top of rail as specified in Sections 2-4.7E [*Downtown Opportunity Area Special Requirements*] and 2-4.8D [*Jasper Place Opportunity Area Special Requirements*] of this Schedule.

3-1.1.5.3 Direct Fixation Track

- A. Provide Direct Fixation Track at the following locations:
1. except as noted in Section 3-1.1.5.2.C [*Embedded Track*] of this Schedule, from the east limit of Elevated Guideway Ramp west of 163 Street to Lewis Farms Stop; and
 2. within the Maintenance and Storage Facilities as described in section 3-1.1.5.5 [*Shop Tracks*] and Section 3-1.1.5.6 [*Yard Tracks*] of this Schedule.
- B. Direct Fixation Track shall be designed and constructed in accordance with the following requirements:
1. the rail fastening system shall be raised above the track slab on a direct fixation support, such as a concrete plinth, to mitigate stray current and the potential for snow/ice and debris build up on the rail fasteners;
 2. provide at least 50 mm of clearance beneath the base of the rail fastener and the Track slab to accommodate installation of traction power and signal cables across the rails without having to be trenched within the Track slab/bridge deck;

3. Direct Fixation support structures shall accommodate Trackway drainage requirements specified in Section 3-5.6.1.D [*Track Drainage*] of this Schedule; and
4. the structural design of the direct fixation support, including anchoring requirements are in accordance with Section 4-2.13 [*Direct Fixation Support*] of this Schedule.

3-1.1.5.4 Transition Zone

- A. Where two types of track construction with varying track modulus abut against one another, a gradual change in track stiffness shall be provided by introducing a transition zone between the two types.
- B. The transition track shall be of sufficient length to be traversed in a minimum of two seconds at the design speed. The track stiffness shall transition uniformly along its length.

3-1.1.5.5 Shop Tracks

- A. Shop Tracks shall be designed and constructed in accordance with this Section 3-1 [*Track*] and Section 8-2.6.3 [*Shop Tracks*] and Section 8-3.6.3 [*Shop Tracks*] of this Schedule.
- B. Direct Fixation track shall be provided on Shop Tracks where drainage is the primary concern, and where under-vehicle access and pedestrian or non-rail equipment movements are infrequent.
 1. Direct Fixation Track may be provided where pedestrian or non-rail equipment movements are frequent within an LRV Storage Area if the design allows for easy passage of pedestrian or non-rail equipment over the rails at these locations.
- C. Embedded Track shall be designed and constructed for Shop Tracks not designated as Direct Fixation Track or Pedestal Track. Embedded Track within the Shop Tracks may be constructed in a similar manner to mainline Embedded Tracks.
- D. All Shop Tracks in the first 5 m immediately inside of an exterior door can slope slightly downward toward the door so as promote drainage and supplemental drainage shall be provided at shop doorways.

3-1.1.5.6 Yard Tracks

- A. Design and Construct all Yard Tracks in accordance with this Section 3-1 [*Track*], Section 8-1.3.3 [*Yards and Yard Tracks*], Section 8-2.5.2 [*Yard and Yard Tracks*] and Section 8-3.5.2 [*Yard and Yard Tracks*] of this Schedule.
- B. All Yard Tracks shall be Embedded Track for a minimum of 5 m in length around all buildings in order to provide a driveable apron.
- C. Track over pipelines within the Gerry Wright OMF West Utility ROW shall be designed and constructed to the requirements identified in this Section 3-1 [*Track*] and Section 8-2.11 [*Pipeline Crossing*] of this Schedule.
- D. Ballasted track may be provided for Yard Tracks within the Gerry Wright OMF where Embedded Track and Direct Fixation Track is not prescribed.
- E. Provide Direct Fixation Track for all Yard and Lead Tracks within the Lewis Farms Storage Facility Site except at grade crossings where the track shall be Embedded Track.

3-1.1.5.7 Lead Tracks

- A. Lead Tracks shall be designed and constructed in accordance with this Section 3-1 [*Track*] and Section 8-2.9 [*Yard Lead Track*] of this Schedule.

3-1.1.5.8 Stations

- A. Provide Direct Fixation Track throughout the WEM and Misericordia Stations with precast panels at the designated crossing points to permit level track crossings.

3-1.2 NOT USED

3-1.3 FUNCTIONAL AND TECHNICAL REQUIREMENTS

3-1.3.1 Track Components

- A. All Track materials shall be new and follow the guidelines and standard practices based on the following reference documents:
 - 1. AREMA Manual for Railway Engineering;
 - 2. AREMA Portfolio of Trackwork Plans;
 - 3. EN Railway Application Standards; and
 - 4. VDV Permanent Way Directives.
- B. Ballast, sub-ballast and tee rail shall adhere to AREMA Standards.

3-1.3.2 Rail

3-1.3.2.1 Running Rail

- A. All running rail on Mainline Track shall be a minimum of 115 lb. RE CWR conforming to the standard carbon steel rail manufacturing standards of Section 3-1 [*Track*] of this Schedule and be fully compatible with the wheel profile of the Stage 1 LRVs, as included in Disclosed Data.
- B. Notwithstanding the requirements of Section 3-1.3.2.1A [*Running Rail*] of this Schedule, Girder Rail compatible with 115 lb. RE rail size, rail profile, metallurgy and the rail/wheel interface requirements may be used.
- C. All running rail and guard rails shall be new and conform to the requirements of AREMA Chapter 4 and be fully head hardened having a Brinell Hardness (BHN) of 365 to 380.
- D. Jointed rail is permitted in Yard Track.

3-1.3.2.2 Restraining Rail

- A. Determine the need for restraining rail in accordance with TCRP Report 155, Sections 2.5.5.4 *Inboard versus Outboard Bearing Trucks* and 4.3 *Guarded Curves and Restraining Rails*, and considering the risk of derailment caused by wheel climb.
 - 1. Where deemed necessary, restraining rail shall be designed and constructed for the rail/wheel interface characteristics and curve radius.
 - 2. Restraining rail may use bolted joints to avoid differences in thermal stress levels between the restraining rail and the adjacent CWR running rail. Restraining rail shall be electrically bonded at joints. The ends of the restraining rail shall be electrically bonded to the adjoining running rail except where track circuits are employed by the Train Control System.
 - 3. In all areas of track requiring restraining rail, ensure the restraining rail fastening assembly is compatible with the Track Clearance Envelope.

3-1.3.2.3 Derailment Protection

- A. Provide guard rail or another form of derailment protection within the Direct Fixation Track sections of the Trackway, where the Trackway is located on:
 - 1. an Elevated Guideway having a vertical height difference between the edge of the Trackway and the immediately adjacent surface of 1 m or greater;
 - 2. an embankment fill section having a slope steeper than 3H:1V, with a total vertical height difference between the edge of the Trackway and the bottom of the slope greater than 1 m;
 - 3. an embankment fill section having a slope equal to, or shallower than, 3H:1V, with a total vertical height difference between the edge of the Trackway and the bottom of the slope greater than 3 m; and
 - 4. at locations where a derailed train would likely impact critical non-transit facilities such as high tension power line poles.
- B. All guard rail and other derailment protection structures shall be designed and constructed to contain the Train within the Trackway in the event of derailment.
- C. Guard rail shall be installed inside the running rails in Direct Fixation Track at bridges and Elevated Guideways.
- D. Where restraining rail is used at guard rail locations, guard rail shall be installed only on the side having no restraining rail.
- E. The ends of guard rail shall be bent into flares pointing toward the track centreline.
- F. Guard rail shall be electrically isolated from the running rail.
- G. Guard rail is not required on Tracks where structural lateral restraints are present which are strong enough to contain a derailed vehicle.

3-1.3.3 Rail Fastening Systems

- A. Mechanical rail fasteners may be provided in lieu or in addition to flexible two-component elastomeric grout for Embedded Track, where deemed necessary by Project Co to ensure lateral stability and constructability. Project Co shall demonstrate the Design meets all performance criteria as specified in this Schedule.
- B. Provide mechanical fasteners for all Direct Fixation Track.
- C. Rail fastening systems shall:
 - 1. hold gauge and absorb the rail forces caused by temperature fluctuation; and
 - 2. dampen vibrations and prevent rail creep caused by rail/wheel interaction.
- D. All fasteners within Direct Fixation Track and Ballasted Track shall permit lateral gauge adjustment. Direct Fixation Track shall allow for vertical adjustment by use of shims.
- E. Fasteners shall resist corrosion and have Design Service Life as defined in Section 1-2.9 [*Design Service Life*] of this Schedule
- F. Standard spacing between Direct Fixation Track and Ballasted Track rail fasteners shall accommodate the rail deflection and rail break gap in accordance with Section 3-1.1.5.1A and

Section 3-1.1.5.1B [*General*] of this Schedule, track design speed in accordance with Section 3-1.1.3 [*Design Speeds*] of this Schedule and loading of all On-track Vehicles.

3-1.3.4 Tie and Ballast

- A. Tie and ballast shall not be permitted on Mainline Track.
- B. All ties shall be pretensioned monoblock concrete ties.
- C. Submit to the City for acceptance a minimum of 30 days before installation the source(s) of ballast that will be used and the test results demonstrating that the ballast meets all of the requirements of this Schedule.
- D. Submit to the City for acceptance a minimum of 14 days before installation the source(s) of sub-ballast that will be used and the test results demonstrating that the sub-ballast and ballast meet all of the requirements of this Schedule.

3-1.3.5 Elastomers and Isolating Materials

- A. All LRT track construction types shall include materials and components that electrically insulate the rail from ground, absorb noise and vibration, and facilitate adjustment of track modulus.
- B. Materials shall be selected that are appropriate to operate in the track environment for a Design Service Life as defined in Section 1-2.9 [*Design Service Life*] of this Schedule.

3-1.3.6 Turnout Standards and Geometry

- A. All turnouts and crossovers shall be designed and constructed to match the turnout size and locations as identified on Figures 5-1A-01 to 5-1A-47 of Appendix 5-1A [*Project Description Drawings*] in Part 1 [*General*] of this Schedule and shall match the geometry and component parts including rail type and rail hardness of Valley Line LRT Stage 1 turnout and crossovers for each Track type as included in the Disclosed Data, except:
 - 1. turnout sizes identified in Figures 5-1A-01 to 5-1A-47 of Appendix 5-1A [*Project Description Drawings*] in Part 1 [*General*], which are not used in Valley Line LRT Stage 1 shall match the same general trackwork requirements and specifications used for the Valley Line LRT Stage 1 turnouts, with the revised geometry and frog angle to fit the Project.
- B. Turnouts are not permitted on any Elevated Guideway or within the limits of a Grade Crossing or pedestrian crossing.
- C. All turnouts within Embedded Track sections shall be constructed using cast-in-place concrete or pre-cast panels as infill material and designed to:
 - 1. maintain the functionality of the switch;
 - 2. not interfere with operation of the Closure Rail; and
 - 3. sustain loading from emergency vehicles including, but not limited to, the weight and turning radius of a standard ladder truck used by Edmonton Fire Rescue Services.
- D. Special trackwork used within the Yard Track shall be of tee rail design, based on 115RE rail section.
- E. All turnouts shall be located on planar, tangent track. Turnouts shall not be located on superelevated track.

- F. All turnouts with a radius 150 m or less shall be designed with an inner restraining rail that creates a fully guarded condition throughout the turnout, and if applicable, throughout the crossover track between two turnouts.
- G. Turnouts shall be fully welded or connected with zero-gap joints.

3-1.3.7 Track Drainage System

- A. All Track, including Mainline Track, Secondary Track, Shop Track and Yard Track shall comply with the applicable requirements of Section 3-5.6 [*Stormwater Management – Specific Facilities*] of this Schedule.
- B. Shop Track shall comply with Section 8-1.3.A11 [*General Requirements*] of this Schedule.

3-1.3.8 Vehicle Overrun Protection

- A. Provide vehicle overrun protection at the end of the Mainline Track, and at all stub-ended Secondary Track, to prevent On-track Vehicles from overrunning the end of the Track.
- B. Determine the requirements for vehicle overrun protection based upon a hazard analysis which shall consider, as a minimum, the following items:
 1. the distance from the normal stopping point to the end of Track;
 2. the Maximum Operating Speed at the approach to the end of the Track, in accordance with Section 1-2.1.2A.4e [*Operational Design Parameters*] of this Schedule;
 3. the likelihood of an overrun incident, considering all plausible events leading up to the incident;
 4. the likelihood of Passengers being onboard the Train at the time of an overrun incident; and
 5. other consequences of an overrun incident, including consideration of pedestrians, vehicles and property beyond the end of Track.
- C. The hazard analysis may also consider mitigations to lessen the probability or consequences of an overrun incident, including:
 1. Driver cab crashworthiness;
 2. operation and responsiveness of Driver's safety device; and
 3. application of a Driver awareness monitoring system.
- D. Where the probability and consequences of an overrun incident can be demonstrated to be low, as consented to by the City, acting reasonably, non-energy absorbing devices may be considered; otherwise, energy absorbing devices shall be provided that, in the event of an overrun incident, shall:
 1. bring a single LRV at AW0 loading to a gradual stop, reflecting the need to balance the risk of damage and/or injury in the stopping zone versus damage to the vehicle and/or injury to the onboard passengers; and
 2. prevent an On-track Vehicle from passing beyond the end of the Track, considering a Train of maximum length and fully loaded to AW4 or other rail-borne auxiliary equipment, if heavier.
- E. The use of landscaping features and/or earth mounds may be considered as overrun protection subject to Acceptance by the City, based upon the results of the hazard assessment completed by Project Co.

3-1.3.9 Switch Blower and Heat Tracing Requirements

- A. Provide a system to keep all switches and associated Closure Rails clear of snow and ice at all times.
 - 1. Heat tracing shall be used for all switches installed in Embedded Track.
 - 2. Cold-air switch blowers shall be used for all Direct Fixation or Ballasted Track.
- B. Where switch blowers are used, they shall be housed within noise reduction enclosures as required to comply with the requirements of Section 1-2.1.5 [*Noise Control*] and Section 2-9.4 [*Wayside Equipment Enclosures*] of this Schedule.
- C. Where heat tracing is used it shall be extended as required to comply with track drainage requirements of Section 3-5.6.1 [*Track Drainage*] of this Schedule.
- D. Any snow clearing systems generating snow melt shall prevent freezing of any run-off generated by the system within the track ROW and within the track drainage that carries the melt away from point of source. All track drainage shall meet the requirements of Section 3-5.6.1 [*Track Drainage*] of this Schedule.

3-1.4 TRACKWAY INTEGRATION

3-1.4.1 Trackway Integration Design Approach

- A. Trackway systems are composed of several elements, each of which has a definite interaction with the other elements of the Infrastructure.
- B. Design for Trackway shall consider track systems in accordance with Section 5 [*System and Safety Assurance*] of Schedule 4 [*Design and Construction Protocols*]. In performing this Trackway design, consideration of associated factors such as safety, Stray Current, ride comfort, noise, and vibration shall not be overlooked. In addition, the relationship of Trackway design to the design of other elements of the Infrastructure, such as train control, drainage and type of LRVs, shall be recognized and accommodated early in the design process.
- C. Design for Trackway shall be fully integrated and optimized with the adjacent Roadway and associated civil design.
- D. The essential elements of a Trackway system include, but are not limited to:
 - 1. roadbed, drainage, and Track foundation slab;
 - 2. loads and environment factors;
 - 3. Direct Fixation Track structure or Embedded Track structure;
 - 4. Ballasted Track structure;
 - 5. rail;
 - 6. rail fastening systems (including elastomers);
 - 7. Special Trackwork; and
 - 8. other Track devices including rail heaters/blowers, lubricators, switch machines, bumping posts and the like.
- E. Without limiting Section 3-1.1.1 [*Reference Standards*] of this Schedule, vertical and horizontal loading from the light rail vehicle shall be in accordance with Stage 1 LRV.

- F. The Design shall accommodate the space requirements for rail profile grinding and rail corrugation grinding.
- G. Project Co shall design and construct the Track to tie-in and be fully integrated with Valley Line LRT Stage 1 Track in accordance with this Section 3-1 [*Track*], and Section 1-1.4 [*Integration with Valley Line LRT Stage 1*].
- H. The rail/wheel interface Design of Valley Line LRT Stage 2 shall be fully compatible for the Valley Line LRT Stage 1.
- I. Project Co shall adhere to the Valley Line LRT Stage 1 rail/wheel interface and rail grinding requirements.
- J. The top of rail to Platform edge and Track centreline to Platform edge dimensions shall match those on Valley Line LRT Stage 1.
- K. Project Co shall ensure that the tolerances between the Track and Stop/Stations Platforms are met and are compliant with TCRP Report 155 requirements.
- L. The Trackway shall be designed and constructed in accordance with Section 4-1.9.1.K [*Geotechnical*] of this Schedule. In addition, the platform and track relationship shall be compliant with TCRP Report 155 requirements and therefore shall be resistant to frost heaving or any other differential settlement condition which may be introduced between the track and platform based upon the results of Project Co's geotechnical investigation

Section 3-2 – ROADWAYS, SIDEWALKS AND SHARED USE PATHS

3-2.1 SCOPE

- A. This section sets out the requirements for all Roadways, sidewalks and Shared Use Paths (SUPs), including all elements of Design and Construction pertaining to streets, alleys, private and commercial accesses, bus stops, signage, delineation, and pavement markings.

3-2.2 DESIGN BASIS AND CRITERIA

3-2.2.1 Design Standards

- A. Without limiting Section 1-1.7 [*Reference Documents*] of this Schedule and except as otherwise specified herein, the Roadways, sidewalks, SUPs and all associated infrastructure shall comply with the requirements of the following codes, standards and regulations:
1. Valley Line West LRT Roadways Design and Construction Standards;
 2. City of Edmonton Access Management Guidelines
 3. City of Edmonton Access Design Guide;
 4. TAC “Geometric Design Guide for Canadian Roads”;
 5. TAC “Manual of Uniform Traffic Control Devices for Canada”;
 6. Alberta Transportation Roadside Design Guide;
 7. TAC “Bikeway Traffic Control Guidelines for Canada”;
 8. TAC “Pedestrian Crossing Control Guide”; and
 9. AASHTO “A Policy on Geometric Design of Highways and Streets”.
- B. In the event of any conflict, ambiguity or inconsistency between or among the requirements of the above listed codes, standards and regulations, the requirements shall apply in the order listed in Section 3-3.2.1A [*Design Standards*] of this Schedule.
- C. The Roadways, sidewalks, SUPs and all associated Roadways infrastructure within the TUC shall comply with the following codes, standards and regulations, except as otherwise specified in this Section 3-2 [*Roadways, Sidewalks and Shared Use Paths*] or in Part 4 [*Transportation Structures and Building Structures*] of this Schedule.
1. Alberta Transportation Standard Specifications for Highway Construction;
 2. Alberta Transportation Highway Geometric Design Guide;
 3. Alberta Transportation Roadside Design Guide; and
 4. Alberta Transportation Standard Specifications for Bridge Construction.

3-2.2.2 Roadways Design Speed

- A. Design all Roadways in accordance with the roadways posted speeds and classifications specified in Tables 3-2.2.1 [*Roadways Posted Speed (Main Alignment)*] and 3-2.2.2 [*Roadways Posted Speed (Cross Streets)*] of this Schedule.

Table 3-2.2.1 Roadways Posted Speed (Main Alignment)

	Roadway	Roadways Posted Speed	Roadway Classification
1.	87 Avenue/Webber Greens Drive (west of 178 Street)	60 km/h	Arterial, transit route
2.	87 Avenue (east of 178 Street)	50 km/h	Arterial, transit route
3.	Meadowlark Road	50 km/h	Arterial, transit route
4.	156 Street	50 km/h	Arterial, transit route
5.	Stony Plain Road (west of 149 Street)	50 km/h	Arterial, transit route
6.	Stony Plain Road (149 Street to 102 Avenue)	50 km/h	Arterial, transit route
7.	Stony Plain Road (east of 102 Avenue)	50 km/h	Arterial, transit route
8.	104 Avenue (west of 116 Street)	50 km/h	Arterial, transit route
9.	104 Avenue (east of 116 Street)	50 km/h	Arterial, truck route
10.	107 Street	50 km/h	Collector
11.	102 Avenue	30 km/h	Arterial

Table 3-2.2.2 Roadways Posted Speed (Cross Streets)

	Roadway	Roadways Posted Speed	Roadway Classification
12.	Access to Lewis Farms Park and Ride/access to West Henday Promenade commercial development	50 km/h	Collector, transit route
13.	East access to Lewis Farms Transit Centre	50 km/h	Collector, transit route
14.	199 Street	50 km/h	Collector
15.	Ramp from southbound Anthony Henday Drive	70 km/h	Arterial, transit route
16.	Ramp to southbound Anthony Henday Drive	50 km/h	Arterial, transit route
17.	Anthony Henday Drive	100 km/h	Freeway
18.	Ramp from northbound Anthony Henday Drive	80 km/h	Arterial, transit route
19.	Ramp to northbound Anthony Henday Drive	35 km/h	Arterial, transit route
20.	TUC Access	30 km/h	Private access
21.	189 Street	50 km/h	Collector, transit route
22.	182 Street	50 km/h	Collector, transit route
23.	178 Street	60 km/h	Arterial, transit route
24.	WEM parkade access	30 km/h	Private access
25.	175 Street	50 km/h	Collector
26.	WEM parking access/west WEM Transit Centre access	30 km/h	Private access, transit route
27.	East WEM Transit Centre access	30 km/h	Collector, transit route
28.	WEM parking access	30 km/h	Private access
29.	172 Street	50 km/h	Local
30.	WEM parking access	30 km/h	Private access

	Roadway	Roadways Posted Speed	Roadway Classification
31.	170 Street	60 km/h	Arterial, transit route, truck route
32.	West access to Misericordia Hospital	50 km/h	Private access
33.	East access to Misericordia Hospital	50 km/h	Private access
34.	169 Street	50 km/h	Collector, transit route
35.	165 Street	50 km/h	Collector, transit route
36.	164 Street	50 km/h	Local
37.	163 Street	50 km/h	Arterial
38.	161 Street	50 km/h	Local
39.	87 Avenue (east) of 159 Street	60 km/h	Arterial, transit route
40.	159 Street	60 km/h	Arterial, transit route
41.	88A Avenue	50 km/h	Local
42.	88B Avenue	50 km/h	Local
43.	89 Avenue	50 km/h	Local
44.	90 Avenue	50 km/h	Local
45.	156 Street (south)	50 km/h	Arterial
46.	91 Avenue	50 km/h	Local
47.	92 Avenue	50 km/h	Collector
48.	92A Avenue	50 km/h	Local
49.	93A Avenue	50 km/h	Local
50.	95 Avenue	50 km/h	Collector, transit route
51.	96 Avenue	50 km/h	Local
52.	97 Avenue	50 km/h	Local
53.	98 Avenue	50 km/h	Local
54.	99 Avenue	50 km/h	Local
55.	100 Avenue (west)	50 km/h	Arterial, transit route
56.	100 Avenue (east)	60 km/h	Arterial
57.	100A Avenue	50 km/h	Collector
58.	Stony Plain Road (west)	50 km/h	Arterial, transit route
59.	156 Street (north)	50 km/h	Arterial, transit route
60.	155 Street	50 km/h	Local
61.	154 Street	50 km/h	Local
62.	153 Street	50 km/h	Local
63.	152 Street	50 km/h	Shared Street
64.	151 Street	50 km/h	Local, transit route
65.	150 Street	50 km/h	Local
66.	149 Street	60 km/h	Arterial, transit route
67.	148 Street	50 km/h	Local
68.	147 Street	50 km/h	Local
69.	146 Street	50 km/h	Local
70.	145 Street	50 km/h	Local
71.	144 Street	50 km/h	Local
72.	143 Street	50 km/h	Local
73.	142 Street (north)	50 km/h	Arterial, transit route
74.	142 Street (south)	60 km/h	Arterial, transit route
75.	140 Street	50 km/h	Local
76.	102 Avenue	50 km/h	Arterial, transit route
77.	139 Street	50 km/h	Local
78.	138 Street	50 km/h	Local

	Roadway	Roadways Posted Speed	Roadway Classification
79.	137 Street	50 km/h	Local
80.	136 Street	50 km/h	Collector
81.	135 Street	50 km/h	Local
82.	134 Street	50 km/h	Local
83.	133 Street	50 km/h	Local
84.	132 Street	50 km/h	Local
85.	131 Street/Glenora Crescent	50 km/h	Local
86.	Connaught Drive	50 km/h	Local
87.	Groat Road	50 km/h	Arterial
88.	129 Street	50 km/h	Local
89.	128 Street	50 km/h	Local
90.	127 Street	50 km/h	Collector
91.	126 Street	50 km/h	Local
92.	125 Street	50 km/h	Local
93.	124 Street	50 km/h	Arterial, transit route
94.	123 Street	50 km/h	Local
95.	122 Street	50 km/h	Local
96.	121 Street	50 km/h	Collector
97.	120 Street	50 km/h	Local, transit route
98.	119 Street	50 km/h	Local
99.	118 Street	50 km/h	Local
100.	117 Street	50 km/h	Local
101.	116 Street (north)	50 km/h	Arterial, transit route, truck route
102.	116 Street (south)	50 km/h	Arterial, transit route
103.	115 Street	50 km/h	Local
104.	114 Street	50 km/h	Local
105.	113 Street	50 km/h	Local
106.	112 Street	50 km/h	Collector
107.	111 Street	50 km/h	Collector
108.	110 Street	50 km/h	Local
109.	109 Street	50 km/h	Arterial, transit route, truck route
110.	108 Street	50 km/h	Collector
111.	103 Ave	50 km/h	Arterial
112.	106 Street	50 km/h	Arterial
113.	105 Street	50 km/h	Arterial, transit route
114.	104 Street	50 km/h	Collector
115.	103 Street	50 km/h	Collector, transit route
116.	102 Street	50 km/h	Collector

B. Design for Roadway and associated civil design shall be fully integrated and optimized with the adjacent Trackway.

3-2.3 SAFETY AUDIT

A. Roadway Safety Audits shall be carried out in accordance with Section 5.8 [*Road Safety Audits*] of Schedule 4.

3-2.4 GEOMETRIC DESIGN

3-2.4.1 General

- A. All Roadways, including existing Roadways that are modified or reconstructed, but not including Roadways within the TUC, shall comply with the standard requirements as specified in the *Valley Line West LRT Roadways Design and Construction Standards*, except as specified in Section 3-2.11 [Area Specific Requirements] of this Schedule.
- B. All Roadways within the TUC shall comply with the standard requirements as specified in the *Alberta Transportation Standard Specifications for Highway Construction*, except as specified in Section 3-2.11 [Area Specific Requirements] of this Schedule.

3-2.4.2 Cross Fall

- A. The cross fall of all Roadways shall be a minimum 0.020 m/m.
- B. The cross fall of all sidewalks and SUPs shall be as prescribed in the *Valley Line West LRT Roadways Design and Construction Standards* except:
 - 1. the maximum crossfall of monolithic sidewalks and SUPs shall be 0.035 m/m.

3-2.4.3 Lane Width

- A. Roadway lane widths shall be the actual finished pavement dimensions measured between pavement markings or between pavement marking and face-of-curb, as applicable.

3-2.4.4 Shy-way Width

- A. The shy-way between the face of curb or vehicular travel lane and any vertical obstruction shall be 1.25m, except:
 - 1. the shy-way between the Track Clearance Envelope and any vehicular travel lane, bike lane or pedestrian area shall be 600 mm;
 - 2. the shy-way between any vehicular travel lane and any vertical obstruction or slab-on median on 102 Avenue between and including 102 Street and 107 Street shall be 600 mm; and
 - 3. the shy-way between the face-of-curb and the elevated guideway piers shall be 1.2 m except between the northbound lanes and any median pier on 170 Street where the shy-way shall be 3.0 m.

3-2.4.5 Median Width

- A. The minimum width of any raised median shall be 1.20 m from face-of-curb to face-of-curb.
- B. Painted medians shall not be greater than 1.20 m in width.

3-2.4.6 Curb and Gutter

- A. Curbs and gutters adjacent to the Trackway shall comply with drawing #5023 in the *Valley Line West LRT Roadways Design and Construction Standards*, except:
 - 1. where there is a marked pedestrian crosswalk across the Tracks. In these locations, the design shall allow for the Trackway to be flush with the Roadway to allow the Barrier-Free passage of pedestrians; and
 - 2. as specified in Section 3-2.11 [Area Specific Requirements] of this Schedule.

- B. All other curbs and gutters throughout the Lands shall comply with drawing #5000 in the *Valley Line West LRT Roadways Design and Construction Standards*, except as specified in Section 3-2.11 [*Area Specific Requirements*] of this Schedule.
- C. All curbs and gutters shall be new construction.
- D. All curbs and gutters along 102 Avenue between and including 102 Street and 107 Street shall be as specified in Section 2-4.7 [*Downtown Opportunity Area Special Requirements*] of this Schedule.
- E. At intersections, the curbs and gutters adjacent to the Trackway shall continue through the intersection, except:
 - 1. at intersections where there are legal vehicular turning movements or through movements across the Trackway; and
 - 2. at pedestrian crosswalks, as referenced in this Section 3-2.4.6A [*Curb and Gutter*] of this Schedule.
- F. Curbs, medians and Trackway shall be constructed such that the Trackway shall be accessible by emergency service vehicles from the adjacent road lane(s) at all locations where there is Embedded Track except where obstructed by a stop platform.

3-2.4.7 Slopes

- A. Slopes located adjacent to Roadways, sidewalks and SUPs shall not be steeper than 3.5H:1V, except:
 - 1. on Groat Road at Stony Plain Road, the side slopes shall be graded to match existing;
 - 2. in McKinnon Ravine, between 149 Street and 147 Street, the ravine slopes shall be shallower or equal to the existing slope steepness in any location; and
 - 3. through the TUC, slopes shall meet the requirements of the *Alberta Transportation Standard Specifications for Highway Construction* and the *Alberta Transportation Standard Specifications for Bridge Construction*.
- B. In areas where these slopes cannot be achieved, retaining walls shall be constructed in accordance with Section 2-11.5 [*Walls*] of this Schedule in order to meet the requirements of Section 3-2.4.7A [*Slopes*] of this Schedule.

3-2.4.8 Width of Ditch

- A. The minimum width of any ditch bottom shall be 1.0 m.

3-2.4.9 Horizontal Clearances

- A. All horizontal clearances shall comply with the requirements specified in Section 3-2.2.1 [*Design Standards*] of this Schedule.

3-2.4.10 Intersections

- A. Intersection design shall comply with the *Valley Line West LRT Roadways Design and Construction Standards*. Intersections shall be designed to the classification of each incoming Roadway, as defined in Table 3-2.2.1 [*Roadways Posted Speed (Main Alignment)*] and Table 3-2.2.2 [*Roadways Posted Speed (Cross Streets)*] of this Schedule and in the City of Edmonton Transportation System Bylaw 15101.

- B. For each section of Roadway, the "Stopping Sight Distance", as defined in the *TAC Geometric Design Guide for Canadian Roads*, shall meet or exceed the upper limit for the design speed of the applicable Roadway section.

3-2.4.11 Shared-Use Paths

- A. All SUPs shall be 3.0 m in width and separated from the Roadway by a boulevard, except as specified in Section 3-2.11 *[Area Specific Requirements]* of this Schedule.
- B. Where a curbline (monolithic) SUP (no boulevard) is specified in Section 3-2.11 *[Area Specific Requirements]* of this Schedule, it shall be a minimum 3.5 m in width, measured from the back of curb.
- C. All SUPs shall allow a clear path of travel, free of obstructions. Connecting curb ramps shall also be free of obstructions.
- D. Boulevard SUPs (SUPs that are separated from the Roadway by a boulevard) shall be detoured behind bus pads to create the required clear space as set out in Section 4000 of the *Valley Line West LRT Roadways Design and Construction Standards*, except as specified in Section 3-2.11 *[Area Specific Requirements]* of this Schedule.

3-2.4.12 Sidewalks

- A. All sidewalks shall be a minimum 1.8 m in width and separated from the Roadway by a boulevard, except as specified in Section 3-2.11 *[Area Specific Requirements]* of this Schedule.
- B. Where a curbline (monolithic or monowalk) sidewalk is specified in Section 3-2.11 *[Area Specific Requirements]* of this Schedule, it shall be a minimum 2.3 m in width measured from the back of curb except:
 - 1. as specified in Section 3-2.11 *[Area Specific Requirements]* of this Schedule; and
 - 2. along 107 Street, 102 Avenue and on adjacent cross streets, and along Stony Plain Road between 149 Street and 156 Street, the width of the sidewalks shall be equal to the distance between the Roadway curb and gutter and the adjacent buildings or property lines.
- C. All sidewalks shall allow a clear path of travel, free of obstructions. Connecting curb ramps shall also be free of obstructions.
- D. Boulevard sidewalks (sidewalks that are separated from the Roadway by a boulevard) shall be detoured behind bus pads to create the required clear space as set out in Section 4000 of the *Valley Line West LRT Roadways Design and Construction Standards*, except as specified in Section 3-2.11 *[Area Specific Requirements]* of this Schedule.

3-2.4.13 Turnarounds

- A. Design all turnarounds to comply with drawing #3040 in the *Valley Line West LRT Roadways Design and Construction Standards*, except as specified in Section 3-2.11 *[Area Specific Requirements]* of this Schedule.

3-2.4.14 Grading

- A. All grading tie-in elevations for private properties shall be at or below existing ground elevations at property line.

3-2.5 PAVEMENT DESIGN REQUIREMENTS

3-2.5.1 New Construction

- A. The minimum pavement structures for the following Roadways shall be as specified in Table 3-2.5.1 [Minimum Pavement Structures (Main Alignment)], Table 3-2.5.2 [Minimum Pavement Structures (Ancillary Locations)] and Table 3-2.5.3 [Minimum Pavement Structures (Alleys and Turnarounds)].

Table 3-2.5.1 Minimum Pavement Structures (Main Alignment)

Roadway	Segment	10mm-HT Asphalt (mm)	20mm-B Asphalt (mm)	3-20mm Granular Base (mm)	Cement Stabilized Subgrade (mm)
Webber Greens Drive/87 Avenue	Future 199 Street to Ramp to/from southbound Anthony Henday Drive	60	120	300	150
87 Avenue (AT jurisdiction)	Anthony Henday Drive Bridge to TUC east boundary	50	90	300	150
87 Avenue	TUC east boundary to 182 Street (all lanes)	50	195	300	150
87 Avenue	182 Street to 178 Street (all lanes)	50	195	300	150
87 Avenue	178 Street to 165 Street	50	215	300	150
87 Avenue	165 Street to 159 Street (all lanes)	50	210	300	150
Meadowlark Road/156 Street	87 Avenue to Stony Plain Road (all lanes)	50	110	300	150
Stony Plain Road	156 Street to 149 Street (all lanes)	50	110	300	150
Stony Plain Road	149 Street to 121 Street (all lanes)	50	175	300	150
104 Avenue	121 Street to 109 Street (all lanes)	50	175	300	150
104 Avenue	109 Street to 105 Street (all lanes)	50	195	300	150
107 Street	104 Avenue to 102 Avenue (all lanes)	250 mm Portland Cement Concrete over 150 mm 3-20mm Ganular Base Course over 150 mm prepared subgrade, in accordance with Section 2-4.7 [Downtown Opportunity Area Special Requirements] of this Schedule			
102 Avenue	107 Street to 102 Street (all lanes)	100mm Concrete Paving Blocks over 25mm Sand over 150 mm Class B Concrete Base over 300 mm 3-20mm Granular Base Course over 150mm Cement Stabilized Subgrade in accordance with Section 2-4.7 [Downtown Opportunity Area Special Requirements] of this Schedule			

Table 3-2.5.2 Minimum Pavement Structures (Ancillary Locations)

Roadway	Segment	10mm-HT Asphalt (mm)	20mm-B Asphalt (mm)	3-20mm Granular Base (mm)	Cement Stabilized Subgrade (mm)
Ramp to/from southbound Anthony Henday Drive	87 Avenue to north construction limit	55	120	300	120
Ramp to/from northbound Anthony Henday Drive	87 Avenue to south construction limit	55	120	300	120
170 Street	To construction limits north and south of 87 Avenue	50 (Stone Mastic Asphalt)	250	400	150
Misericordia Hospital internal roads	From 87 Avenue at the west access to 87 Avenue at the east access	50	100	300	150
Former Meadowlark bus loop	Meadowlark Road	75		300	150
Service Road south of 92 Avenue along Meadowlark Road	South entrance to north entrance	No mill and overlay required			
100A Avenue	Transit Centre to 156 Street	150 mm Jointed Plain Class A Concrete Pavement		150	150
102 Avenue	Stony Plain Road to 138 Street	50	100	300	150
Service Road east of Groat Road along Stony Plain Road	Woodbend Place to Sylvanecroft Lane	90 10mm-LT		300	150

Table 3-2.5.3 Minimum Pavement Structures (Alleys and Turnarounds)

Roadway	Required Pavement Structure
Alley SW corner of 156 Street/Stony Plain Road (100A Avenue to existing alley between 100 Avenue and 100A Avenue)	150 mm Jointed Plain Class A Concrete Pavement; 150mm 3-20mm Granular Base Course; 150 mm Cement Stabilized Subgrade
Alley turnaround between 106 Street and 105 Street – North construction limit to 102 Avenue	As specified in Section 2-4.7 [<i>Downtown Opportunity Area Special Requirements</i>] of this Schedule
Other Residential Alleys	100 mm 10mm-LT; 175 mm 3-20mm Granular Base Course centre and 250mm 3-20mm Granular Base Course edge; 150 mm Cement Stabilized Subgrade or geogrid
Other Residential Turnarounds	100 mm 10mm-LT; 250mm 3-20mm Granular Base Course; 150 mm Cement Stabilized Subgrade or geogrid
Other Commercial Alleys	50 mm 10mm-HT; 75 mm 20mm-B; 300 mm 3-20mm Granular Base Course centre and 375mm 3-20mm Granular Base Course edge; 150 mm Cement Stabilized Subgrade or geogrid
Other Commercial Turnarounds	50 mm 10mm-HT; 75 mm 20mm-B; 300 mm 3-20mm Granular Base Course centre and 375mm 3-20mm Granular Base Course edge; 150 mm Cement Stabilized Subgrade or geogrid

- B. All Roadways, alleys, parking lots, and service roads not listed in Table 3-2.5.1 [*Minimum Pavement Structures (Main Alignment)*], Table 3-2.5.2 [*Minimum Pavement Structures (Ancillary Locations)*] and Table 3-2.5.3 [*Minimum Pavement Structures (Alleys and Turnarounds)*] shall be constructed of asphalt, in accordance with the *Valley Line West LRT Roadways Design and Construction Standards*, to match existing pavement structure.
- C. All sections of Roadway listed in Table 3-2.5.1 [*Minimum Pavement Structures (Main Alignment)*] shall be fully reconstructed, including the curbs.
- D. All sections of Roadway listed in Table 3-2.5.2 [*Minimum Pavement Structures (Ancillary Locations)*] shall be fully reconstructed as required to tie into the existing roadway in accordance with this Section 3-2.5 [*Pavement Design Requirements*] of this Schedule unless specified otherwise.
- E. Removal of existing pavement structure shall be such that the edge of any pavement structure that is to be retained shall be in the centre or along the lane lines of the future traffic lanes.
- F. If the distance from the final surface elevation to the top of an existing vault structure on 102 Avenue is less than the required 102 Avenue pavement structure depth in Table 3-2.5.1 [*Minimum Pavement Structures (Main Alignment)*] of this Schedule, but more than the paver thickness in accordance with Section 2-4.7B [*Downtown Opportunity Area Special Requirements*] of this Schedule plus 25 mm and the structural integrity of the vault is confirmed by the vault owner, then the pavement structure may be reduced to the paver thickness plus 25 mm bedding sand and 150 mm minimum Class B concrete base over the existing vault structure.
- G. If the distance from the final surface elevation to the top of an existing vault structure on 102 Avenue is nominally the thickness of the paver in accordance with Section 2-4.7B [*Downtown Opportunity Area Special Requirements*] of this Schedule plus 25 mm bedding sand and the structural integrity of

the vault is confirmed by the vault owner, then the pavement structure may be reduced to the paver plus the nominal 25 mm bedding sand.

- H. Final stage paving for Roadways parallel to the LRT Trackway shall be completed from lip of gutter to lip of gutter for the length of each Roadway segment from cross street to cross street as a minimum, including any existing pavement structure that remains and shall not be completed for a minimum of 365 days from the time base paving is completed. Prefill may be required prior to final stage paving.
- I. For final stage paving for Roadways that cross the LRT Trackway, mill and overlay to the full width of any lane or lanes impacted or adjacent to work on that Roadway.
- J. Roadways that are not impacted by Construction do not require an overlay other than to tie in.
- K. Pavement structures for SUPs and sidewalks shall comply with the following:
 - 1. *Valley Line West LRT Roadways Design and Construction Standards*;
 - 2. where SUPs or sidewalks will be utilized as an access for maintenance or emergency vehicles as specified in Section 3-2.11 [*Area Specific Requirements*] of this Schedule, the pavement structure shall be designed to accommodate such use;
 - 3. all boulevard SUPs shall be constructed of asphalt, in accordance with *Valley Line West LRT Roadways Design and Construction Standards*;
 - 4. the SUP between the trail around the existing stormwater pond and the former 199 Street south of the the Lewis Farms Storage Facility may be constructed from gravel to match the appearance of the trail around the existing stormwater pond;
 - 5. all curblines (monolithic) SUPs shall be constructed of concrete, in accordance with *Valley Line West LRT Roadways Design and Construction Standards*;
 - 6. all sidewalks shall be constructed of concrete, in accordance with *Valley Line West LRT Roadways Design and Construction Standards* except as set out in this Section 3-2.5.1K.6 [*New Construction*] of this Schedule; and
 - 7. all sidewalks along 107 Street, 102 Avenue and on adjacent cross streets, shall be constructed as specified in Section 2-4.7 [*Downtown Opportunity Area Special Requirements*] and Section 2-14.10 [*Downtown Character Zone Landscape Requirements*] of this Schedule.
- L. All bus stop amenity pads shall be constructed of concrete in accordance with the *Valley Line West LRT Roadways Design and Construction Standards*.
- M. The minimum pavement structures for the on-street bus pads required by Section 3-2.6 [*Bus Stops*] of this Schedule shall be as specified on drawing #4250 of the *Valley Line West LRT Roadways Design and Construction Standards*.
- N. All alley, residential, commercial and industrial crossings shall be concrete, in accordance with the *Valley Line West LRT Roadways Design and Construction Standards*.
- O. For any Roadway where there is a mix of partial depth pavement removal, full depth pavement removal and mill and overlay, ensure the transition between existing and new pavement structure provides consistency between the performance of the existing and new pavement through the full section.
- P. Where new curb and gutter ties into existing curb and gutter, any transition in the curb height shall occur over a distance of 10 horizontal to 1 vertical. Lip of gutter tie-ins shall be designed to match.

- Q. Except as specified in Table 3-2.5.1 [*Minimum Pavement Structures (Main Alignment)*], Table 3-2.5.2 [*Minimum Pavement Structures (Ancillary Locations)*] and Table 3-2.5.3 [*Minimum Pavement Structures (Alleys and Turnarounds)*], where new Roadway ties in to existing Roadway, the new pavement structure shall match the existing pavement structure and shall not impede sub-surface drainage.

3-2.6 BUS STOPS

- A. Provide bus stops, bus lay-bys and amenity pads at the locations specified in Table 3-2.6 [*Bus Stop Requirements*].
- B. Bus stops shall comply with the *Valley Line West LRT Roadways Design and Construction Standards*.
- C. Bus lay-bys shall be designed to accommodate a City of Edmonton Articulated Bus, as defined in Figure 3-3.2.3-2 [*City of Edmonton Articulated Bus Profile*] of this Schedule, entering, exiting, and stopping parallel to the curb face, except as otherwise specified in Table 3-2.6 [*Bus Stop Requirements*].
1. An additional 1.2 m shall be added to the front overhang shown in Figure 3-3.2.3-2 [*City of Edmonton Articulated Bus Profile*] of this Schedule, to allow for an extended bike rack.
 2. The width of the buses shown in Figure 3-3.2.3-1 [*City of Edmonton Bus Profile*], 3-3.2.3-2 [*City of Edmonton Articulated Bus Profile*] and Figure 3-3.2.3-3 [*City of Edmonton Electric Bus Profile*] of this Schedule shall be increased to 3.15m to include the wing mirrors.
- D. Not used.
- E. The City shall design, supply and install all shelters, bus stop signs, benches, litter receptacles and other furniture associated with the new bus stops. Notify the City in writing, not less than 17 Business Days and not more than 25 Business Days prior to a bus stop amenity pad being complete and ready for opening, in accordance with Section 1-1.3 [*City Works*] of this Schedule. The number of bus stops opening in any week shall not exceed five (5).
- F. Replacement bus service stops are required to allow LRT passengers to access replacement buses in the event that the LRT cannot operate due to an emergency or scheduled maintenance. Provide a replacement bus service stop in each direction at each LRT Stop, except:
1. at Lewis Farms Stop in the westbound direction;
 2. at Jasper Place Stop in the southbound direction;
 3. at NorQuest Stop in the southbound direction; and
 4. at Alex Decoteau Stop in the westbound direction.
- G. Each replacement bus service stop shall be located within line of sight of the platform it is replacing and be located along the mainline roadway within 100m of the platform. Bus stops listed in Table 3-2.6 [*Bus Stop Requirements*] can be used as replacement bus service stops if they meet the sightline and distance requirements of the *Valley Line West LRT Roadways Design and Construction Standards*. If no regular bus stop is available, the replacement bus service bus may be located on a section of roadway where there is only one lane of traffic in that direction. Provide a hard surfaced, accessible connection between each replacement bus service stop and the platform it is replacing.
- H. Where a replacement bus service stop is not located at a regular bus stop, provide the following at each replacement bus service stop:

1. a 17 m length straight faced curb to comply with drawing #5000 in the *Valley Line West LRT Roadways Design and Construction Standards*;
2. a 17 m long concrete pad behind the curb joining the curb with the adjacent boulevard sidewalk or SUP. If the adjacent sidewalk or SUP is curblined (monolithic) sidewalk or SUP, then no concrete pad is required; and
3. to allow easy access to the bus doors, no physical obstructions are permitted in the following locations along the 17m contingency bus service bus stop, measured from the head of the bus stop:
 - a. 0 m to 1.5 m for the front doors;
 - b. 4.5 m to 8.5 m for the rear doors; and
 - c. 11.5 m to 14 m for the rear doors (articulated bus).

Table 3-2.6 Bus Stop Requirements

Bus Stop Street	Direction	Location	Shown on Schedule 5 Part 1, Appendix 5-1A, Figure #	Lay-by Required	Bus Stop Pad (In Street) Length	Amenity Pad Required	Notes
Webber Greens Drive	Westbound	East of Suder Greens Drive/206 Street	N/A	N/A	N/A	N/A	Existing bus stop
Webber Greens Drive	Eastbound	East of Suder Greens Drive/206 Street	N/A	N/A	N/A	N/A	Existing bus stop
87 Avenue	Westbound	West of 189 Street	5-1A-5	No	21 m	9 m x 4 m in front of SUP	New bus stop to replace the existing stop in similar location.
87 Avenue	Westbound	East of 189 Street	5-1A-5	No	21 m	9 m x 4 m in front of SUP	New bus stop to replace the existing bus stop which is ~140 m east of the new location.
87 Avenue	Eastbound	East of 189 Street	5-1A-5	No	21 m	12 m x 3 m between roadway and track	New bus stop to replace the existing stop in similar location.
87 Avenue	Westbound	West of 182 Street	5-1A-6	No	21 m	12 m x 3 m in front of SUP	New bus stop to replace the existing stop which is ~140 m east of the new location.
87 Avenue	Eastbound	West of 182 Street	5-1A-6	No	21 m	12 m x 3 m in between roadway and track	New bus stop to replace existing stop in similar location
182 Street	Southbound	South of 87 Avenue	5-1A-7	No	21 m	9 m x 4 m behind sidewalk	New bus stop to replace the existing stop in similar location
87 Avenue	Eastbound	East of 182 Street	5-1A-7	No	21 m	9 m x 4 m in front of walk	New bus stop to replace the existing stop in similar location.
87 Avenue	Westbound	East of 182 Street	5-1A-7	No	21 m	12 m x 3 m in front of SUP	New bus stop. Does not replace an existing stop.

Bus Stop Street	Direction	Location	Shown on Schedule 5 Part 1, Appendix 5-1A, Figure #	Lay-by Required	Bus Stop Pad (In Street) Length	Amenity Pad Required	Notes
87 Avenue	Westbound	Halfway between 182 Street and 178 Street	5-1A-7	No	21 m	12 m x 3 m in front of SUP	New bus stop to replace the existing bus stop which is ~135 m east of the new location
87 Avenue	Eastbound	Halfway between 182 Street and 178 Street	5-1A-8	No	21 m	12 m x 3 m in front of sidewalk	New bus stop to replace the existing stop which is ~30 m west of new location.
178 Street	Southbound	South of 87 Avenue	5-1A-8	No	21 m	12 m x 3 m in front of sidewalk	New bus stop to replace the existing stop in similar location.
87 Avenue	Eastbound	East of 178 Street	5-1A-8	No	21 m	12 m x 3 m in front of SUP	New bus stop to replace the existing stop which is ~8 m east of the new location.
87 Avenue	Westbound	In front of West Edmonton Mall Transit Centre	5-1A-45	See Section 3-3 [West Edmonton Mall Transit Centre] of this Schedule			
87 Avenue	Eastbound	East of 175 Street	5-1A-9	No	21 m	12 m x 3 m within sidewalk	New bus stop to replace the existing stop in similar location.
175 Street	Southbound	South of 87 Avenue	5-1A-9	No	21 m	9 m x 4 m behind sidewalk	New bus stop to replace the existing stop in similar location.
87 Avenue	Westbound	West of 172 Street	5-1A-10	No	21 m	9 m x 4 m in front of SUP	New bus stop to replace the existing stop in similar location.
87 Avenue	Eastbound	East of 172 Street	5-1A-10	No	21 m	12 m x 3 m in front of sidewalk	New bus stop to replace the existing stop in similar location.
87 Avenue	Westbound	West of 169 Street	5-1A-13	No	21 m	9 m x 4 m in front of SUP	New bus stop to replace the existing stop in similar location.
87 Avenue	Eastbound	West of 169 Street	5-1A-13	No	21 m	12 m x 3 m in front of sidewalk	New bus stop to replace the existing stop in similar location.
87 Avenue	Westbound	West of 165 Street	5-1A-13	No	21 m	9 m x 4 m in front of SUP	New bus stop to replace the existing stop in similar location.
87 Avenue	Eastbound	West of 165 Street	5-1A-13	No	21 m	9 m x 4 m in front of sidewalk	New bus stop to replace the existing stop which is ~85 m east) of the new location.

Bus Stop Street	Direction	Location	Shown on Schedule 5 Part 1, Appendix 5-1A, Figure #	Lay-by Required	Bus Stop Pad (In Street) Length	Amenity Pad Required	Notes
87 Avenue	Westbound	West of 163 Street	5-1A-14	No	21 m	9 m x 4 m in front of sidewalk	New bus stop to replace the existing stop which is ~18 m west of the new location.
163 Street	Northbound	North of 87 Avenue	5-1A-14	No	21 m	No	New bus stop to replace the existing stop in median adjacent to service road.
87 Avenue	Eastbound	East of 163 Street	5-1A-15	No	21 m	12 m x 3 m in front of sidewalk	New bus stop to replace the existing stop which is ~196 m east of the new location
87 Avenue	Eastbound	East of 161 Street	5-1A-15	No	21 m	9 m x 4 m in front of sidewalk	New bus stop to replace the existing stop in similar location. New location shall avoid proposed new access to Meadowlark Professional Building.
87 Avenue	Westbound	West of 159 Street	5-1A-15	No	21 m	12 m x 3 m in behind sidewalk	New bus stop to replace the existing stop in similar location.
87 Avenue	Eastbound	East of 159 Street	5-1A-16	No	21 m	12 m x 3 m behind sidewalk	New bus stop to replace the existing stop in similar location.
87 Avenue	Westbound	East of 159 Street	5-1A-16	No	21 m	9 m x 4 m behind sidewalk	New bus stop to replace the existing stop in similar location.
95 Avenue	Eastbound	East of 156 Street	5-1A-21	No	21 m	12 m x 3 m in behind sidewalk	New bus stop to replace the existing stop which is ~40 m east of the new location.
Stony Plain Road	Westbound	West of 148 Street	5-1A-26	No	21 m	9 m x 4 m within the plaza area	New bus stop in combined layby/right turn bay stop to replace the existing stop which is ~100m east of the new location.
Stony Plain Road	Eastbound	West of 147 Street	5-1A-27	Yes, 30 m	Full length of bus stop and lay-by.	9 m x 4 m behind sidewalk	New bus stop to replace the existing stop in similar location.

Bus Stop Street	Direction	Location	Shown on Schedule 5 Part 1, Appendix 5-1A, Figure #	Lay-by Required	Bus Stop Pad (In Street) Length	Amenity Pad Required	Notes
Stony Plain Road	Westbound	West of 145 Street	5-1A-27	Yes, 25 m	Full length of bus stop and lay-by.	No	New bus stop to replace the existing stop which is ~105 m west of the new location.
Stony Plain Road	Eastbound	West of 145 Street	5-1A-27	Yes, 25 m	Full length of bus stop and lay-by.	9 m x 4 m behind sidewalk	New bus stop to replace the existing stop ~30 m west of the new location.
Stony Plain Road	Westbound	West of 142 Street	5-1A-28	Yes, 35 m	Full length of bus stop and lay-by.	12 m x 3 m at end of sidewalk	New bus stop to replace the existing stop in similar location.
Stony Plain Road	Eastbound	West of 142 Street	5-1A-28	No	21 m	9 m x 4 m within the plaza area	New bus stop to replace the existing stop in similar location.
Stony Plain Road	Eastbound	East of 142 Street	5-1A-29	No	21 m	12 m x 3 m on island between Stony Plain Road and service road	New bus stop to replace the existing stop which is on the right-turn island ~55 m west of the new location.
104 Avenue	Eastbound	West of 107 Street	5-1A-40	No	21 m	9 m x 4 m behind sidewalk	New bus stop to replace existing stop in similar location.
104 Avenue	Westbound	West of 107 Street	5-1A-40	No	21 m	12 m x 3 m in front of sidewalk	New bus stop to replace existing stop in similar location.
104 Avenue	Westbound	West of 105 Street	5-1A-41	No	21 m	Extend existing bus pad to the curb	New bus stop to replace the existing stop in similar location.

3-2.7 BICYCLE PARKING

- A. At a minimum, provide the number of bicycle racks specified in Table 3-2.7 [*Bicycle Racks Required at Each Stop/Station*], which shall be constructed in accordance with the requirements of Section 2-10.2.10 [*Bicycle Racks*] of this Schedule.

Table 3-2.7 Bicycle Racks Required at Each Stop/Station

Stop/Station	Number of Bicycle Racks
Lewis Farms Stop	in accordance with Section 3-4.3.4 [<i>Bicycle Facilities</i>] of this Schedule
Aldergrove/Belmead Stop	20
West Edmonton Mall Station	in accordance with Section 3-3.3.5A [<i>West Edmonton Mall Transit Centre Bicycle Parking</i>] of this Schedule
Misericordia Station	15
Meadowlark Stop	25
Glenwood/Sherwood Stop	15
Jasper Place Stop	30
Stony Plain Road/149 Street Stop	10
Grovenor/142 Street Stop	10
Glenora Stop	15
124 Street	25
Brewery/120 Street Stop	15
The Yards/116 Street Stop	10
MacEwan Arts/112 Street Stop	None
NorQuest Stop	10
Alex Decoteau Stop	10

- B. Locate the bicycle racks at Lewis Farms Stop in accordance with Section 3-4.3.4 [*Bicycle Facilities*] of this Schedule.
- C. Locate the bicycle racks at West Edmonton Mall Station in accordance with Section 3-3.3.5A [*West Edmonton Mall Transit Centre Bicycle Parking*] of this Schedule.
- D. Bicycle racks at all other Stops and Stations shall be located within 50 m of a Platform Access Point and may be clustered in groups.
- E. All existing bicycle racks removed to accommodate the Construction shall be replaced with racks of an equal or better design or shall be stored by Project Co and reinstalled within the same street block, so as to accommodate the same number of bicycles.
- F. Bicycle racks shall be provided at Amenity Nodes as specified in Section 2-4.4 [*Amenity Nodes*] of this Schedule.

3-2.8 SIGNING, DELINEATION AND PAVEMENT MARKINGS

3-2.8.1 Signing

- A. Provide all Roadway, pedestrian, and bicycle signage required to guide, regulate and control traffic and reinstate all existing information signage within the Lands in accordance with the requirements of MUTCD (Canada), except as follows:
1. the City shall supply all “regulatory”, “traffic control” and “information” signs as defined in MUTCD (Canada) in accordance with the Accepted Final Designs provided by Project Co; and

2. the City shall install all “regulatory”, “traffic control” and “information” signs as defined in MUTCD (Canada) in accordance with the Accepted Final Designs provided by Project Co, including “regulatory” and “traffic control” signs to be mounted on traffic signal poles or arms. Provide the City with sufficient notice that the Roadway or SUP will be complete and ready for opening, in accordance with Section 1-1.3 [*City Works*] of this Schedule.
- B. Provide all other active and static Roadways signage required for operation of the Valley Line West LRT.
 - C. Maintain all existing or temporary “regulatory” and “traffic control” signage until permanent signage is installed.

3-2.8.2 Delineation Markers

- A. Where delineation markers are required, they shall comply with the requirements of MUTCD (Canada).

3-2.8.3 Pavement Markings

- A. Provide all Roadway, pedestrian, and bicycle pavement markings required to guide, regulate and control traffic within the Lands in accordance with the requirements of *City of Edmonton Design and Construction Standards*, Volume 8 – Pavement Markings, 2012 and the TAC manuals referred to in Section 3-2.2.1A [*Design Standards*] of this Schedule, except:
 1. the City shall supply and install all permanent pavement markings except for the lane lines and crosswalk lines on 107 Street and 102 Avenue that are integrated into the pavers described in Section 2-4.7B [*Downtown Opportunity Area Special Requirements*] of this Schedule, in accordance with the Accepted Final Designs provided by Project Co. Provide the City with sufficient notice that the Roadway will be complete and ready for public use, in accordance with Section 1-1.3 [*City Works*] of this Schedule.
- B. Maintain all existing or temporary pavement markings until permanent pavement markings are installed.

3-2.9 ROAD APPURTENANCES

- A. Provide all road appurtenances required by the Road Safety Audits, including traffic barriers, pedestrian barriers, and protective netting, or an alternative which has been accepted by the City.
- B. Where median or roadside barriers are required, such barriers, including end treatments, shall be designed in accordance with the *Alberta Transportation Roadside Design Guide* and comply with *Alberta Transportation Standard Specifications for Highway Construction*.

3-2.10 RESTORATION OF INFRASTRUCTURE

- A. Where Existing Infrastructure is impacted by Construction, restore or reconstruct all such infrastructure, including all Roadways, sidewalks, driveways, SUPs, curbs and gutters, medians, traffic islands, storm drain systems, Utilities, signs, markings, street lighting, streetscape and landscaping.
- B. Where elevation or grading of Existing Infrastructure, including sidewalks, driveways and other accesses, is impacted by Construction, restore existing conditions so that the new infrastructure shall match the existing grades at the boundary of the City Lands. Where final grading does not permit the restoration of existing sidewalks and driveways to within 10 mm of the existing grade without introduction of a step(s), transitions shall be provided using a ramp meeting the NBCAE requirements, without adversely affecting the grades and drainage within the adjacent land. Where access to property outside the Lands is required in order to complete such tie-ins, obtain temporary

access easements and remedial construction agreements to allow access in accordance with Section 4.16 *[Work on Adjoining Lands]* of the Agreement and Section 3-2.4.7 *[Slopes]* of this Schedule.

3-2.11 AREA SPECIFIC REQUIREMENTS

3-2.11.1 General Requirements

- A. The lane assignments, lane direction and vehicle turning movement requirements along the length of the LRT Corridor shall be as shown on Figures 5-1A-01 to 5-1A-44 of Appendix 5-1A *[Project Description Drawings]* in Part 1 *[General]* of this Schedule.
- B. The minimum, maximum and recommended lane widths shall be as set out in the *Valley Line West LRT Roadways Design and Construction Standards*.
- C. Turning bay lengths at intersections shall be as shown on Figures 5-1A-01 to 5-1A-44 of Appendix 5-1A *[Project Description Drawings]* in Part 1 *[General]* of this Schedule.
- D. Signalized intersections shall be provided in the locations listed in Table 6-4.3-1 *[Traffic Intersections]* in Part 6 *[[Systems]* of this Schedule.
- E. Left turns shall be prohibited at all intersections except in those locations shown on Figures 5-1A-01 to 5-1A-44 of Appendix 5-1A *[Project Description Drawings]* in Part 1 *[General]* of this Schedule.
- F. In any intersections where traffic running parallel to the Trackway is permitted to make a left or right turning movement across the Trackway, a separate left turn or right turn bay shall be provided for that turning movement.
- G. Provide crosswalks on all sides of signalized intersections except as otherwise specified in this Section 3-2.11 *[Area Specific Requirements]* of this Schedule.
- H. Provide “mid-block” crosswalks in the locations listed in Table 6-4.3-2 *[Pedestrian Activated Signal Locations]* and Table 6-4.3.3 *[Pedestrian Crossing of LRT Locations]* in Part 6 *[[Systems]* of this Schedule.
- I. Provide curb extensions at all crosswalks across Roadways with on-street parking to minimize pedestrian crossing distances.
- J. All crosswalks which cross the track shall be controlled by pedestrian signals as detailed in Section 6-4.3 *[Traffic Signal Equipment]* of this Schedule.
- K. Multiple stage crosswalks, where the crossing of opposite directions of roadway or the crossing of the roadway and track are on separate traffic signal phases, shall have a horizontal stagger between crosswalks for each stage. The stagger shall be a minimum offset of the crosswalk width plus 1 m.
- L. Provide curb ramps at all crosswalks. The width of the ramp shall equal the width of the adjacent walk or SUP.
- M. All sidewalks, SUPs and Roadways constructed as part of the Project shall provide a seamless transition into the applicable existing infrastructure.
 - 1. Where a sidewalk, SUP or Roadway is provided parallel to an existing parking lot and abuts the existing parking lot, provide a curb at the edge of the City Lands. Where the distance between the edge of sidewalk or SUP and the edge of the City Lands is less than 0.5 m, a hard surface shall be provided in accordance with the applicable Character Zone. Where the distance between the edge of sidewalk or SUP and the edge of the City Lands is greater than 0.5 m, a grassed surface shall be provided.

2. Where an existing SUP or sidewalk has been realigned as part of the Construction, all private walk connections from all residences, businesses and other facilities adjacent to the SUP or sidewalk shall be re-established without negative impacts on existing infrastructure.
- N. Except as otherwise specified in this Section 3-2.11 *[Area Specific Requirements]* of this Schedule, re-establish all SUPs and sidewalks that are impacted by the Construction in accordance with *Valley Line West LRT Roadways Design and Construction Standards*, but to the same geometrical standard as the applicable existing SUPs and sidewalks.
- O. Where SUPs are leading to a sidewalk or plaza area, there must be clear visual cues of the different uses through delineation, pavement material types and signage. Set design elevations and grading such that the grade difference between the back of Platform and the integrated sidewalk or adjacent property is no greater than 10 mm at the following locations:
1. south Platform at Aldergrove/Belmead Stop;
 2. west Platform at Jasper Place Stop;
 3. north Platform at Grovenor/142 Street Stop; and
 4. west Platform at NorQuest Stop.
- P. Preserve all vehicular and pedestrian accesses between a Roadway and land adjacent to that Roadway, including accesses to existing parkades, alleys, private driveways, and commercial properties except as otherwise specified in this Section 3-2.11 *[Area Specific Requirements]* or as shown in Appendix 5-3A *[Access and Road Closure Drawings]* of this Schedule.
- Q. Coordinate permanent Road Closures, Access Closures and Connection Removals in accordance with Appendix 5-3A *[Access and Road Closure Drawings]* of this Schedule.
1. For Road Closures and Access Closures, Project Co shall block vehicular access with physical means no earlier than the bylaw effective date and no later than 12 months after the bylaw effective date as listed in Table 3-2.11.1 *[Road Closure and Access Closure Bylaw Effective Dates]* except as otherwise specified in this Section 3-2.11 *[Area Specific Requirements]* of this Schedule.

Table 3-2.11.1 Road Closure and Access Closure Bylaw Effective Dates

Closure Group	Road Closure and Access Closure identifications	Bylaw effective date
1 (City owned Properties)	108-H; 109-K; 116-J; 120-P; 120-Q; 120-V2; 120-X; 120-Y; 123-P; 123-BB; 127-R; 130-E; 130-L; 130-Q; 130-W; 131-B; 131-L; 131-T; 131-V; 132-I; 132-J; 132-N; 132-S; 132-T; 133-C; 134-I; 134-L; 139-I; 139-N; 139-O	April 1, 2021
2 (Area 1)	139-P; 139-Q; 139-R; 141-D; 141-G	June 1, 2021
3 (Area 2)	135-L; 136-J	May 1, 2021
4 (Area 3)	128-J; 129-A; 129-D; 130-O; 131-N; 131-Y; 132-C; 134-B; 134-H	November 1, 2021
5 (Area 4)	123-E; 123-J; 123-K; 123-M; 123-O; 123-EE; 123-PP; 126-N1; 126-N2; 127-H; 127-P	July 1, 2021
6 (Area 5a)	113-A; 113-H; 114-F; 116-E; 116-F; 116-H; 116-I; 116-Q; 116-R; 116-W; 118-A; 118-B; 118-C	June 1, 2022

Closure Group	Road Closure and Access Closure identifications	Bylaw effective date
7 (Area 5b)	118-H; 119-E; 119-F; 119-P; 119-Q; 119-R; 119-S; 119-U; 119-V; 119-X; 119-Y; 119-Z; 119-AA; 119-BB; 119-CC; 119-DD; 119-EE; 119-FF; 119-GG; 119-HH	June 1, 2021
8 (Area 5c)	120-F; 120-G1; 120-G2; 120-H1; 120-H2; 120-O; 120-S; 120-T; 120-U; 120-V1; 122-L; 122-N; 122-O	June 1, 2021
9 (Area 6)	105-A; 111-M; 112-G; 112-H; 112-N	March 1, 2021

2. For Road Closures and Access Closures, provide the City six (6) months advance notice prior to the closure of a Roadway or access except:
 - a. for Group 1 accesses, no notice shall be required; and
 - b. as otherwise specified in this Section 3-2.11 *[Area Specific Requirements]* of this Schedule.
 3. Notice of Road Closures or Access Closures as identified in Appendix 5-3A *[Access and Road Closure Drawings]* of this Schedule, shall be given by group as listed in Table 3-2.11.1 *[Road Closure and Access Closure Bylaw Effective Dates]* and not by individual access.
 4. A Road Closure or Connection Removal cannot be implemented until any new Roadway, alley or turnaround acting as an alternative route for traffic using that road or alley has been constructed, if no alternative exists. Provide the required signage, barricades and restore the closed Roadway or alley to a natural landscaped area and comply with the requirements of the applicable road closure permits.
 5. Connection Removals shown on Figures 5-3A-1 to 5-3A-44 of Appendix 5-3A *[Access and Road Closure Drawings]* of this Schedule shall be treated in the same manner as temporary road closures and require submission of a Traffic Accommodation Request (TAR) and Traffic Accommodation Plan (TAP) in accordance with Section 1-4 *[Transportation Management]* of this Schedule, except as otherwise specified in this Section 3-2.11 *[Area Specific Requirements]* of this Schedule.
- R. Where the Trackway runs along the centre of the Roadway, left turns shall be prohibited out of and into all private accesses and alley accesses adjacent to the Roadway.
- S. On-street parking facilities including parking lanes, DATS parking, maintenance vehicle parking and Kiss and Rides, shall be in the locations shown on Figures 5-1A-1 to 5-1A-43 of Appendix 5-1A *[Project Description Drawings]* in Part 1 *[General]* of this Schedule.
- T. In consultation with the City, provide a safe location at each Stop or Station for a maintenance vehicle to park without impeding traffic or the LRT.
1. The design vehicle for the maintenance bays shall be a Light Single Unit Truck, as defined in TAC.

3-2.11.2 Webber Greens Drive (West Project Limit to Existing Anthony Henday Drive Bridge)

- A. Webber Greens Drive (west project limit to Existing Anthony Henday Drive Bridge) shall be as shown on Figures 5-1A-01 to 5-1A-03 of Appendix 5-1A *[Project Description Drawings]* in Part 1 *[General]* of this Schedule.
- B. All existing Roadways and sidewalks shall be retained between the west project limit and the Existing Anthony Henday Drive Bridge with the exception of the following sections:

1. between the entrance to West Henday Promenade (the commercial area on the north side of Webber Greens Drive) west of the project limits and the ramp to and from southbound Anthony Henday Drive, provide an additional westbound through lane;
 2. provide an additional crosswalk across the east leg of the Webber Greens Drive / Lewis Farms Park and Ride Access intersection; and
 3. it is anticipated that 199 Street will be relocated from its current location westwards to opposite the east access to Lewis Farms Transit Centre at some point during the Construction Period. This work is driven by the development to the north and will be completed by Other Contractors. The Webber Greens Drive / Future 199 Street intersection shall be constructed as a signalized intersection as shown on Figure 5-1A-02 of Appendix 5-1A [*Project Description Drawings*] in Part 1 [*General*] of this Schedule.
- C. Road Closures, Access Closures and Connection Removals along Webber Greens Drive (West Project Limit to Existing Anthony Henday Drive Bridge) shall be as shown on Figures 5-3A-01 to 5-3A-03 of Appendix 5-3A [*Access and Road Closure Drawings*] of this Schedule.
- D. The minimum, maximum and recommended lane widths within the TUC shall be as set out in the *Valley Line West LRT Roadways Design and Construction Standards*. Where new roadway ties into existing roadway with lane widths that exceed the design widths, a suitable transition shall be included.
- E. The layout of the Trackway and Roadway through the TUC shall allow for changes to the interchange configuration with Anthony Henday Drive in accordance with Alberta Transportation's Hwy. 216 / Anthony Henday Drive Functional Planning Study 2008, including the trackway elevation in the TUC where it will be crossed by the future ramp to southbound Anthony Henday Drive.
- F. The layout of the Trackway and Roadway at the ramp to/from southbound Anthony Henday Drive shall allow for the addition of Automatic Grade Crossing Warning Systems as required.

3-2.11.3 87 Avenue (87 Avenue from Existing Anthony Henday Drive Bridge to East of 182 Street)

- A. 87 Avenue (Existing Anthony Henday Drive Bridge to East of 182 Street) shall be as shown on Figures 5-1A-04 to 5-1A-07 of Appendix 5-1A [*Project Description Drawings*] in Part 1 [*General*] of this Schedule.
- B. All existing Roadways and sidewalks shall be retained between the Existing Anthony Henday Drive Bridge and the ramp to/from northbound Anthony Henday Drive with the exception of the following sections:
1. along the south side of 87 Avenue between the Existing Anthony Henday Drive Bridge and the ramp to/from northbound Anthony Henday Drive where a right turn bay shall be added, and the existing pork chop island removed.
- C. Provide a signalized stop line on the northbound to eastbound ramp lane at the trackway.
- D. The minimum, maximum and recommended lane widths within the TUC shall be as set out in the *Valley Line West LRT Roadways Design and Construction Standards*. Where new roadway ties into existing roadway with lane widths that exceed the design widths, a suitable transition shall be included.
- E. The layout of the Trackway and Roadway through the TUC shall allow for changes to the interchange configuration with Anthony Henday Drive in accordance with Alberta Transportation's Hwy. 216 / Anthony Henday Drive Functional Planning Study 2008.

- F. The layout of the Trackway and Roadway at the ramp to/from northbound Anthony Henday Drive shall allow for the addition of Automatic Grade Crossing Warning Systems as required.
- G. Not used.
- H. Provide SUPs and sidewalks as specified in Table 3-2.11.3 *[87 Avenue (Existing Anthony Henday Drive Bridge to East of 182 Street) SUP/Sidewalk Requirements]*.

Table 3-2.11.3 87 Avenue (Existing Anthony Henday Drive Bridge to East of 182 Street) SUP/Sidewalk Requirements

Road	From	To	Side	Minimum Boulevard Width	Minimum Sidewalk/SUP Width	Notes
87 Avenue	Anthony Henday Drive	Ramp to/from northbound Anthony Henday Drive	North	No sidewalk or SUP		
87 Avenue	Anthony Henday Drive	Ramp to/from northbound Anthony Henday Drive	South	2.25 m	3.00 m SUP	
87 Avenue	Ramp to/from northbound Anthony Henday Drive	East TUC boundary	North	4.00 m	3.00 m SUP	
87 Avenue	Ramp to/from northbound Anthony Henday Drive	East TUC boundary	South	No sidewalk or SUP		
87 Avenue	East TUC boundary	Walk from 87A Avenue east of 188 Street	North	N/A	3.50 m mono SUP	
87 Avenue	East TUC boundary	New walk from 86A Avenue east of 188 Street	South	No sidewalk or SUP		
87 Avenue	New walk from 86A Avenue east of 188 Street	Bus stop east of new walk from 86A Avenue east of 188 Street	South	N/A	2.30 m monowalk	
New walk east of 188 Street	86A Avenue	87 Avenue	N/A	N/A	3.00 m walk	This walk shall be constructed to support maintenance vehicles accessing the adjacent ATCO facility.
87 Avenue	Walk from 86A Avenue east of 188 Street	Walk from 184 Street	South	~1.60 m	1.80 m walk	This walk is located on the south side of the tracks. Boulevard is measured between Track Clearance Envelope and sidewalk.

Road	From	To	Side	Minimum Boulevard Width	Minimum Sidewalk/SUP Width	Notes
87 Avenue	Walk from 184 Street	Aldergrove / Belmead Stop	South	Varies	3.25 m walk	This walk is located on the south side of the tracks.
87 Avenue	Walk from 184 Street	Aldergrove / Belmead Stop	South	N/A	3.10 m walk	This walk is located on the north side of the tracks.
87 Avenue	New walk from 87A Avenue east of 188 Street	~100 m west of 182 Street	North	2.60 m	3.00 m SUP	
87 Avenue	~100 m west of 182 Street	~40 m east of 182 Street	North	N/A	3.50 m mono SUP	
87 Avenue	Aldergrove / Belmead Stop	182 Street	South	N/A	3.00-4.00 m walk	This walk is located on the south side of the tracks.
87 Avenue	Aldergrove / Belmead Stop	182 Street	South	N/A	4.00-5.00 m monowalk	This walk is located on the north side of the tracks.

- I. Road Closures, Access Closures and Connection Removals along 87 Avenue (Anthony Henday Drive Bridge to East of 182 Street) shall be as shown on Figures 5-3A-04 to 5-3A-07 of Appendix 5-3A [Access and Road Closure Drawings] of this Schedule.
- J. The access to 8660 – 182 Street (Pembroke Estates) parking lot on the south side of 87 Avenue immediately west of 182 Street, shall be closed except for emergency access. Curb and gutter across this access shall comply with drawing #5023 in the *Valley Line West LRT Roadways Design and Construction Standards*. Install lockable bollards to prevent access by all but emergency vehicles.
- K. Access from westbound 87 Avenue to the north TUC shall be a standard commercial access.
- L. Provide a new 9.0 m wide access to the south TUC off the ramp from northbound Anthony Henday Drive to 87 Avenue. This access shall be located roughly in line with 86A Avenue to the east. The access shall be constructed of gravel and the apron shall extend 10.0 m upstream and 10.0 m downstream of the centreline of the access to allow a large mower to stop fully outside of the through traffic lanes.
- M. Provide a lockable gate(s) across the full width of the new access to the south TUC in accordance with Drawing CB-6-2.12M2 [Class 'B' Fence] of the Alberta Transportation Highway Geometric Design Guide.
- N. Remove the existing connection to the south TUC from 87 Avenue denoted as 103-E on Figure 5-3A-04 of Appendix 5-3A [Access and Road Closure Drawings] of this Schedule in accordance with Section 3-2.11.1 [General Requirements]. The connection shall not be removed until the new access to the south TUC is fully operational. Provide 6 months' notice to the City prior to removing the connection.

3-2.11.4 87 Avenue (East of 182 Street to 159 Street)

- A. 87 Avenue (East of 182 Street to 159 Street) shall be as shown on Figures 5-1A-7 to 5-1A-16 of Appendix 5-1A [Project Description Drawings] in Part 1 [General] of this Schedule.
- B. The eastbound to northbound left turn bay at 178 Street shall be located on the north side of the 87 Avenue Elevated Guideway.
- C. Remove the existing service roads in the following locations:
 - 1. along the north side of 87 Avenue between the 165 Street intersection and the 159 Street intersection; and
 - 2. along the south side of 87 Avenue between the 169 Street intersection and the 161 Street intersection.
- D. Adjust the service roads on 163 Street so that they terminate between 87 Avenue and the alley immediately north of 87 Avenue.
- E. Provide SUPs and sidewalks as specified in Table 3-2.11.4 [87 Avenue (East of 182 Street to 159 Street) SUP/Sidewalk Requirements].

Table 3-2.11.4 87 Avenue (East of 182 Street to 159 Street) SUP/Sidewalk Requirements

Road	From	To	Side	Minimum Boulevard Width	Minimum Sidewalk/SUP Width	Notes
87 Avenue	182 Street	Start of the elevated guideway	South	Varies	1.80 m walk	
87 Avenue	182 Street	Walk along the east side of Aldergrove Park	South	N/A	1.80 m	This walk is located on the south side of the tracks.
87 Avenue	Start of the elevated guideway	Walk along the east side of Aldergrove Park	South	N/A	2.30-4.20 m monowalk	Width of walk to extend between the roadway and the elevated guideway ramp.
87 Avenue	~40 m east of 182 Street	178 Street	North	2.60 m	3.00 m SUP	
87 Avenue	Walk along the east side of Aldergrove Park	178 Street	South	2.50 m	1.80 m walk	
178 Street	87 Avenue	North project limits	West	Varies	1.50 m walk	Walk to tie in with existing at project limits
178 Street	87 Avenue	South project limits	West	2.50 m	1.80 m walk	Walk to tie in with existing at project limits
178 Street	87 Avenue	North project limits	East	Varies	1.80 m walk	Walk to tie in with existing at project limits
178 Street	87 Avenue	South project limits	East	2.50 m	1.80 m walk	Walk to tie in with existing at project limits
87 Avenue	178 Street	Mall exit east of 178 Street	North	N/A	2.30 m monowalk	
87 Avenue	178 Street	Mall exit east of 178 Street	South	2.50 m	3.00 m SUP	
87 Avenue	Mall exit east of 178 Street	~65 m west of 175 Street	North	2.50 m	1.80 m walk	
87 Avenue	~65 m west of 175 Street	175 Street	North	N/A	2.50 m monowalk	Adjacent to Kiss and Ride bay
87 Avenue	~65 m west of 175 Street	175 Street	North	N/A	1.80 m walk	Secondary walk towards guideway

Road	From	To	Side	Minimum Boulevard Width	Minimum Sidewalk/SUP Width	Notes
87 Avenue	Mall exit east of 178 Street	~130 m west of 175 Street	South	1.00 m	3.00 m SUP	
87 Avenue	~130 m west of 175 Street	~60 m west of 175 Street	South	2.50 m	3.00 m SUP	
87 Avenue	~60 m west of 175 Street	175 Street	South	N/A	3.90 m SUP	
87 Avenue	175 Street	East Transit Centre access	North	N/A	N/A	~4 m wide South Passenger Loading Area of WEM Transit Centre
87 Avenue	East Transit Centre access	WEM parking access east of the Transit Centre	North	Varies	3.00 m SUP	SUP shall run from the bike parking under the station to the maintenance vehicle bay and then along 87 Avenue.
87 Avenue	East Transit Centre access	~40m east of east Transit Centre access	North	Varies	1.80 m walk	Joins with the SUP
87 Avenue	WEM parking access east of the Transit Centre	WEM parking access east of 172 Street	North	3.60 m	3.00 m SUP	
87 Avenue	WEM parking access east of 172 Street	170 Street	North	2.50 m	3.00 m SUP	Immediately west of 170 Street, the SUP shall become a 3.50 m mono SUP and connections shall be provided to West Edmonton Mall parking
87 Avenue	175 Street	WEM parking access east of the Transit Centre	South	N/A	Monowalk varies	Full width walk to property line
87 Avenue	WEM parking access east of the Transit Centre	172 Street	South	1.00 m	1.80 m walk	
87 Avenue	172 Street	~35 m west of 170 Street	South	Varies	1.80 m walk	
87 Avenue	~35 m west of 170 Street	170 Street	South	N/A	2.30 m monowalk	
87 Avenue	170 Street	~30m west of Misericordia west access	North	N/A	3.00 m SUP	Runs along the north side of the elevated guideway.

Road	From	To	Side	Minimum Boulevard Width	Minimum Sidewalk/SUP Width	Notes
87 Avenue	~20 m east of 170 Street	~30 m west of Misericordia west access	North	2.85 m	1.80 m walk	
87 Avenue	~30 m west of Misericordia west access	Misericordia west access	North	2.85 m	3.00 m SUP	
87 Avenue	~30 m west of Misericordia west access	Misericordia west access	North	N/A	1.80 m walk	Walk wraps around the north side of the elevated guideway
87 Avenue	Misericordia west access	Misericordia east access	North	2.50m	N/A	Full width sidewalk around Misericordia Station. Boulevard shall be provided adjacent to 87 Avenue where there is no kiss and ride layby or bus pad.
87 Avenue	Misericordia west access	Misericordia Utility Complex	North	N/A	Monowalk varies	Plaza area in front of Utility Complex
87 Avenue	Misericordia east access (169 Street)	165 Street	North	Varies	3.00 m SUP	Maximize boulevard, while accommodating bridge piers and bus stop pad.
87 Avenue	170 Street	165 Street	South	2.50 m	1.80 m walk	
87 Avenue	165 Street	~70 m east of 165 Street	North	1.30 m	1.80 m walk	
87 Avenue	~70 m east of 165 Street	~50 m west of 163 Street	North	N/A	2.30 m monowalk	
87 Avenue	~50 m west of 163 Street	~30 m east of 163 Street	North	Varies	2.30 m walk	
87 Avenue	~30 m east of 163 Street	159 Street	North	N/A	2.30 m monowalk	
87 Avenue	165 Street	~160 m west of 161 Street (at bus pad)	South	N/A	2.30 m monowalk	
87 Avenue	~160 m west of 161 Street	159 Street	South	2.50 m	1.80 m walk	
87 Avenue	159 Street	~80 m east of 159 Street	North	N/A	2.30 m monowalk	Walk continues to the west side of vehicle access.

Road	From	To	Side	Minimum Boulevard Width	Minimum Sidewalk/SUP Width	Notes
87 Avenue	159 Street	~60 m east of 159 Street	South	N/A	2.30 m monowalk	
159 Street	87 Avenue	~50 m south of 87 Ave	East	N/A	2.30 m monowalk	Walk to tie into existing 1.50 m walk.

- F. Road Closures, Access Closures and Connection Removals along 87 Avenue (East of 182 Street to 159 Street) shall be as shown on Figures 5-3A-07 to 5-3A-16 of Appendix 5-3A [*Access and Road Closure Drawings*] of this Schedule.
- G. Provide a new access road into the Misericordia Hospital from the 169 Street intersection. This access road shall link with the west Misericordia Hospital access from 87 Avenue. It shall have two inbound lanes and one outbound lane, except on the approach to the 87 Avenue / 169 Street intersection where there shall be one inbound lane and two outbound lanes. Three (3) Barrier-Free angled parking stalls and three (3) regular angled parking stalls shall be provided between the hospital building and the Misericordia Station.
- H. Reconfigure the east access to 16438 – 87 Avenue (gas station) so that it is perpendicular to 87 Avenue.
- I. Reconfigure the west access to the parking behind 8700 Meadowlark Road (the Meadowlark Professional Building) so that it is perpendicular to 87 Avenue.
- J. Provide a retaining wall adjacent to the road along the west side of 170 Street, south of 87 Avenue, that connects into the existing retaining wall. The height of the adjacent berm at any location along 170 Street shall not be reduced.

3-2.11.5 Meadowlark Road and 156 Street (87 Avenue to Stony Plain Road)

- A. Meadowlark Road and 156 Street (87 Avenue to Stony Plain Road) shall be as shown on Figures 5-1A-16 to 5-1A-24 of Appendix 5-1A [*Project Description Drawings*] in Part 1 [*General*] of this Schedule.
- B. The southbound to westbound right turn onto 99 Avenue at 156 Street shall be prohibited.
- C. 100A Avenue shall be closed to vehicular traffic at 156 Street.
- D. Provide a pork chop island on the north east side of the 156 Street/Stony Plain Road intersection.
- E. Remove the existing service roads in the following locations:
 - 1. along the west side of Meadowlark Road between the 87 Avenue intersection and the 91 Avenue intersection.
 - 2. along the west side of 156 Street between the 92 Avenue intersection and north of the 93A Avenue intersection.
 - 3. along the west side of 156 Street between the 98 Avenue intersection and the 99 Avenue intersection.
- F. The service road the west side of 156 Street between 91 Avenue and 92 Avenue shall be retained and an overlay applied.
- G. Curb and gutter along both sides of Meadowlark Road, adjacent to the Platforms of the Meadowlark Stop shall comply with drawing #5023 in the *Valley Line West LRT Roadways Design and Construction Standards*.
- H. Curb and gutter along the west side of 156 Street, adjacent to the outbound Platform of the Glenwood Sherwood Stop shall comply with drawing #5023 in the *Valley Line West LRT Roadways Design and Construction Standards*.

- I. Curb and gutter along the east side of 156 Street, adjacent to the inbound Platform of the Glenwood Sherwood Stop shall comply with drawing #5023 in the *Valley Line West LRT Roadways Design and Construction Standards*.
- J. Curb and gutter along both sides of 100A Avenue between 156 Street and Jasper Place Transit Centre shall comply with drawing #5023 in the *Valley Line West LRT Roadways Design and Construction Standards*.
- K. Provide SUPs and sidewalks as specified in Table 3-2.11.5 [*Meadowlark Road and 156 Street (87 Avenue to Stony Plain Road) SUP/Sidewalk Requirements*].

Table 3-2.11.5 Meadowlark Road and 156 Street (87 Avenue to Stony Plain Road) SUP/Sidewalk Requirements

Road	From	To	Side	Minimum Boulevard Width	Minimum Sidewalk/SUP Width	Notes
Meadowlark Road	87 Avenue	88B Avenue	West/ Northwest	N/A	2.30 m monowalk	
Meadowlark Road	87 Avenue	~75 m north of 87 Avenue at access off Meadowlark Road	East	N/A	2.30 m monowalk	
Meadowlark Road	~75 m north of 87 Avenue at access off Meadowlark Road	88A Avenue	East/ Southeast	2.50 m	1.80 m walk	
Meadowlark Road	88A Avenue	~45m SW of 89 Avenue	Southeast	N/A	N/A	Plaza located along this stretch (~9.2 m wide)
Meadowlark Road	88B Avenue	89 Avenue	Northwest	2.50 m	1.80 m walk	
Meadowlark Road	~45 m SW of 89 Avenue	89 Avenue	Southeast	1.80 m	1.80 m walk	
Meadowlark Road	89 Avenue	Start of service road (along 156 Street)	Northwest	N/A	2.30 m monowalk	Monowalk widens at the large curb bulb outs at 90 Avenue and 156 Street to be ~4.00-4.80 m.
Meadowlark Road	89 Avenue	~50 m SW of 90 Avenue	Southeast	2.10 m	1.80 m walk	
Meadowlark Road	~50 m SW of 90 Avenue	90 Avenue	Southeast	4.10 m	1.80 m walk	
Meadowlark Road	90 Avenue	156 Street	Southeast	2.00 m	1.80 m walk	
Meadowlark Road/156 Street	156 Street	92 Avenue	East	2.60 m	1.80 m walk	Walk also ties in to existing two walks to the south.
156 Street	End of service road (along 156 Street)	~90 m north of 93A Avenue	West	N/A	2.30 m monowalk	

Road	From	To	Side	Minimum Boulevard Width	Minimum Sidewalk/SUP Width	Notes
92 Avenue	156 Street	~40 m west of 156 Street	North	N/A	1.50 m walk and 2.00 m walk	1.50m walk runs parallel to 92 Avenue and ties into existing. 2.00 m width for curved walk and section intersecting triangle.
92 Avenue	156 Street	~65 m east of 156 Street	South	2.00 m	2.00 m walk	
156 Street	92 Avenue	92A Avenue	East	3.25 m	1.80 m walk	
156 Street	92A Avenue	93A Avenue	East	3.75 m	1.80 m walk	
156 Street	93A Avenue	~120 m north of 93A Avenue	East	2.60 m	1.80 m walk	
156 Street	~120 m north of 93A Avenue	95 Avenue	East	N/A	5.00 m monowalk	Plaza area around Glenwood / Sherwood Stop
156 Street	~90 m north of 93A Avenue	~120 m north of 93A Avenue	West	N/A	5.00 m monowalk	Plaza area around Glenwood / Sherwood Stop
156 Street	~120 m north of 93A Avenue	~65 m south of 95 Avenue	West	N/A	2.30 m monowalk	
156 Street	~65 m south of 95 Avenue	95 Avenue	West	N/A	5.00 m monowalk	Plaza area around Glenwood / Sherwood Stop
156 Street	95 Avenue	~80 m south of 96 Avenue	West	N/A	2.30 m monowalk	
156 Street	~80 m south of 96 Avenue	96 Avenue	West	Varies	1.80 m walk	
156 Street	95 Avenue	~50 m north of 95 Avenue	East	N/A	Varies, ~4.00 m monowalk	Plaza area around Glenwood / Sherwood Stop
156 Street	~50 m north of 95 Avenue	96 Avenue	East	N/A	5.00 m monowalk	Plaza area around Glenwood / Sherwood Stop
156 Street	96 Avenue	98 Avenue	West	N/A	2.30 m monowalk	
156 Street	96 Avenue	98 Avenue	East	3.50 m	1.80 m walk	
156 Street	98 Avenue	~75 m north of 98 Avenue	West	3.50 m	1.80 m walk	
156 Street	~75 m north of 98 Avenue	99 Avenue W	West	Varies	1.80 m walk	
156 Street	98 Avenue	~85 m north of 98 Avenue	East	4.00 m	1.80 m walk	

Road	From	To	Side	Minimum Boulevard Width	Minimum Sidewalk/SUP Width	Notes
156 Street	~85 m north of 98 Avenue	99 Avenue E	East	N/A	2.30 m monowalk	Walk remains 1.80 m wide until it transitions into monowalk.
156 Street	99 Avenue W	100 Avenue	West	2.00 m	2.00 m walk	
156 Street	99 Avenue E	100 Avenue	East	1.95 m	1.80 m walk	
156 Street	100 Avenue	100A Avenue	West	N/A	4.00m monowalk	
156 Street	100A Avenue	Stony Plain Road	West	N/A	Monowalk varies	Full width walk to property line
156 Street	100 Avenue	Stony Plain Road	East	N/A	Monowalk varies	Full width walk to property line
100A Avenue	156 Street	Jasper Place Transit Centre	North	N/A	~10.0 m monowalk	Full width walk to property line
100A Avenue	156 Street	Jasper Place Transit Centre	South	N/A	~1.5 m monowalk	To match into existing
156 Street	Stony Plain Road	~55 m north of Stony Plain Road	West	N/A	Monowalk varies, (~5.00 m-6.30 m)	Full width walk to property line
156 Street	~55 m north of Stony Plain Road	~80 m north of Stony Plain Road	West	N/A	2.00 m monowalk	

- L. Road Closures, Access Closures and Connection Removals along Meadowlark Road and 156 Street (87 Avenue to Stony Plain Road) shall be as shown on Figures 5-3A-16 to 5-3A-24 of Appendix 5-3A *[Access and Road Closure Drawings]* of this Schedule.
- M. Meadowlark Transit Centre shall be closed and restored to parking lot. The concrete bus loop may be retained. Remove all existing islands and replace with asphalt pavement in accordance with Section 3-2.5 *[Pavement Design Requirements]* of this Schedule. Provide notice of the closure in accordance with Section 1-3.6.8 *[Construction Around Meadowlark Health and Shopping Centre (156 Street and 87 Avenue)]* in Part 1 *[General]* of this Schedule.
- N. Reconfigure the north access to the parking behind 8700 Meadowlark Road (the Meadowlark Professional Building) so that it is perpendicular to 156 Street.
- O. The existing access from 99 Avenue to 15603 – 99 Avenue (St. Gregorios Orthodox Church) may be relocated westwards by Other Contractors before the start of construction. If this is the case, the parking layby currently shown to the west of the existing access on Figure 5-1A-23 of Appendix 5-1A *[Project Description Drawings]* in Part 1 *[General]* of this Schedule shall be moved the east side of the relocated access.
- P. Provide a new 6 m wide north-south alley link adjacent to the west side of 156 Street between the east-west alley north of 100 Avenue and 100A Avenue.
- Q. Provide a new 6 m wide north-south alley along the east side of 15626 100A Avenue, between 100A Avenue and the alley between 100A Avenue and Stony Plain Road.
- R. Provide a turnaround at the east end of the east-west alley west of 156 Street between 100A Avenue and Stony Plain Road.
- S. Provide a new 6 m wide north-south alley link adjacent to the east side of 156 Street between the private parking area along the south side of Stony Plain Road between 156 Street and 155 Street and the east-west alley between Stony Plain Road and the Orange Hub.
- T. The access on the east side of 156 Street from the east-west alley between Stony Plain Road and the Orange Hub shall be right out only and shall be constructed in a manner that deters all other turning movements.
- U. For Connection Removal 123-I as shown on Figure 5-3A-24 of Appendix 5-3A *[Access and Road Closure Drawings]* of this Schedule, provide the City six (6) months advance notice prior to implementing the Connection Removal in addition to the requirements of Section 3-2.11.1Q *[General Requirements]* of this Schedule.

3-2.11.6 Stony Plain Road (156 Street to 149 Street)

- A. Stony Plain Road (156 Street to 149 Street) shall be as shown on Figures 5-1A-24 to 5-1A-26 of Appendix 5-1A *[Project Description Drawings]* in Part 1 *[General]* of this Schedule.
- B. Curb and gutter along both sides of Stony Plain Road, adjacent to the platforms of the Stony Plain Road/149 Street stop shall comply with drawing #5023 in the *Valley Line West LRT Roadways Design and Construction Standards*.
- C. Existing perpendicular parking facilities on the side streets shall be retained except where Figures 5-1A-24 to 5-1A-26 of Appendix 5-1A *[Project Description Drawings]* require them to be replaced by parallel parking.
- D. Provide SUPs and sidewalks as specified in Table 3-2.11.6 *[Stony Plain Road (156 Street to 149 Street) SUP Requirements]*.

Table 3-2.11.6 Stony Plain Road (156 Street to 149 Street) SUP/Sidewalk Requirements

Road	From	To	Side	Minimum Boulevard Width	Minimum Sidewalk/SUP Width	Notes
Stony Plain Road	156 Street	149 Street	North	N/A	Monowalk varies	Full width walk to property line / URW
Stony Plain Road	156 Street	151 Street	South	N/A	Monowalk varies	Full width walk to property line / URW
154 Street	Stony Plain Road	~45 m north of Stony Plain Road	East	N/A	~4.80 m monowalk	New curb alignment to replace parking stalls with parallel parking. Sidewalk ties into existing at north end.
154 Street	Stony Plain Road	~45 m south of Stony Plain Road	East	N/A	~3.80 m monowalk	New curb alignment to replace parking stalls with parallel parking. Sidewalk ties into existing at south end.
Stony Plain Road	152 Street	151 Street	South	N/A	~2.0 m monowalk	Full width walk to property line
Stony Plain Road	151 Street	150 Street	South	N/A	Monowalk varies	Full width walk to property line
Stony Plain Road	150 Street	149 Street	South	N/A	2.30 m monowalk	

- E. Provide cycle crossing facilities for the north/south movements at the 153 Street intersection in accordance with Section 6-4.3.5.3 [*Bike Signals and Detection*] of this Schedule.
- F. Road Closures, Access Closures and Connection Removals along Stony Plain Road (156 Street to 149 Street) shall be as shown on Figures 5-3A-24 to 5-3A-26 of Appendix 5-3A [*Access and Road Closure Drawings*] of this Schedule.
- G. Construct the entrances to 152 Street north and south from Stony Plain Road as concrete commercial accesses.

3-2.11.7 Stony Plain Road (149 Street to 139 Street)

- A. Stony Plain Road (149 Street to 139 Street) shall be as shown on Figures 5-1A-26 to 5-1A-29 of Appendix 5-1A [*Project Description Drawings*] in Part 1 [*General*] of this Schedule.
- B. The southbound to westbound right turn out of 139 Street onto Stony Plain Road shall be prohibited.
- C. The existing bus loop on the south side of Stony Plain Road west of the 147 Street intersection shall be closed and reinstated in accordance with Section 2-14.9 [*Grovenor and Glenora Character Zone Landscape Requirements*] of this Schedule.
- D. Provide SUPs and sidewalks as specified in Table 3-2.11.7 [*Stony Plain Road (149 Street to 139 Street) SUP Requirements*].

Table 3-2.11.7 Stony Plain Road (149 Street to 139 Street) SUP/Sidewalk Requirements

Road	From	To	Side	Minimum Boulevard Width	Minimum Sidewalk/SUP Width	Notes
Stony Plain Road	149 Street	148 Street	North	N/A	Monowalk varies	Full width walk to property line / URW
Stony Plain Road	149 Street	145 Street	South	N/A	2.30 m monowalk	Monowalk continues around SE corner of 149 Street to Summit Drive.
Stony Plain Road	148 Street	146 Street	North	N/A	2.30 m monowalk	
Stony Plain Road	146 Street	~55 m east of 146 Street	North	2.40m	1.80 m walk	
Stony Plain Road	~55m east of 146 Street	145 Street	North	N/A	2.20 m monowalk	
Stony Plain Road	145 Street	144 Street	North	N/A	2.30 m monowalk	
Stony Plain Road	145 Street	~40 m east of 144 Street	South	N/A	1.50 m monowalk	
Stony Plain Road	~40 m east of 144 Street	143 Street	South	Varies	1.80 m walk	
Stony Plain Road	144 Street	~60 m east of 144 Street	North	N/A	3.00 m SUP / 3.00 m Furnishing Zone	
Stony Plain Road	~60 m east of 144 Street	142 Street	North	Varies	3.00 m SUP / 3.00 m Furnishing Zone	3.00 m SUP / 3.00 m Furnishing Zone is a varying distance from the curb, all on north side of LRT tracks.
Stony Plain Road	~45 m west of 142 Street	142 Street	North	N/A	2.00 m monowalk	On south side of LRT tracks, connects new bus pad to NW corner at 142 Street (wider than 2.00 m at curb bulb).
Stony Plain Road	143 Street	142 Street	South	N/A	Monowalk varies	Full width walk to property line
142 Street	~10 m north of Stony Plain Road	~40 m north of Stony Plain Road	East	N/A	1.50 m monowalk	Monowalk continues north on east side of 142 Street, until ~5 m past existing bus stop.
Stony Plain Road	142 Street	~115 m east of 142 Street	North	N/A	2.00 m walk	Walk along north side of Grovenor/142 Street Station.

Road	From	To	Side	Minimum Boulevard Width	Minimum Sidewalk/SUP Width	Notes
Stony Plain Road	~25 m east of 142 Street	~50 m east of 142 Street	South	3.50 m	1.80 m walk	Walk to tie in to existing south sidewalk and connect to crosswalk to access new bus pad.
Stony Plain Road	~35 m west of 140 Street	140 Street	North	N/A	3.00 m walk	This walk is on the north side of the LRT tracks, distance from tracks varies.
Stony Plain Road	140 Street	139 Street	North	N/A	3.00 m SUP	This SUP is on the north side of the LRT tracks.
Stony Plain Road	~35 m west of 140 Street	~10 m east of 140 Street	North	N/A	~3.00 m monowalk	This monowalk is on the south side of the LRT tracks, along the curb.
Stony Plain Road	~10 m east of 140 Street	102 Ave Intersection	North	4.00 m	3.00 m SUP	This SUP is on the south side of the LRT tracks, connecting to crosswalk across Stony Plain Road.
102 Avenue	West Crosswalk	East Crosswalk	Centre Boulevard	N/A	1.20 m walk	Walk is in centre boulevard, connecting two crosswalks across 102 Avenue (~14 m length).
Stony Plain Road	102 Avenue	~35 m north of 102 Avenue	South	1.65 m	1.80 m walk	
Stony Plain Road	~35 m north of 102 Avenue	~65 m west of 138 Street	South	N/A	2.00 m monowalk	

- E. The existing T-bollards at the sidewalk connection to Ravine Point shall be relocated to accommodate the realigned sidewalk along the south side of Stony Plain Road.
- F. Road Closures, Access Closures and Connection Removals along Stony Plain Road (149 Street to 139 Street) shall be as shown on Figures 5-3A-26 to 5-3A-29 of Appendix 5-3A [*Access and Road Closure Drawings*] of this Schedule.
- G. For Road Closure 127-P as shown as on Figure 5-3A-28 of Appendix 5-3A [*Access and Road Closure Drawings*] of this Schedule, 143 Street shall be closed to vehicular traffic between the north side of Stony Plain Road and the alley north of Stony Plain Road.
- H. For Road Closure 128-J as shown as on Figure 5-3A-29 of Appendix 5-3A [*Access and Road Closure Drawings*] of this Schedule, 140 Street shall be closed to vehicular traffic at Stony Plain Road.
- I. Provide a retaining wall at the back of the sidewalk around McKinnon Ravine between the 149 Street intersection and the existing bus loop where the requirements of 3-2.4.7 [*Slopes*] cannot be met.
- J. The north end of the MacKinnon Ravine Pedestrian Bridge shall be adjusted to tie in with the new sidewalk along the south side of Stony Plain Road.

3-2.11.8 Stony Plain Road (139 Street to 121 Street)

- A. Stony Plain Road (139 Street to 121 Street) shall be as shown on Figures 5-1A-29 to 5-1A-36 of Appendix 5-1A [*Project Description Drawings*] in Part 1 [*General*] of this Schedule.
- B. Across the Stony Plain Road Bridge, the lane width between lip of gutter adjacent to the trackway and face of barrier adjacent to the sidewalk/SUP shall be a minimum of 4.0m.
- C. Provide a new 6 m wide service road on the south side of Stony Plain Road between Woodbend Place and Sylvanecroft Lane.
- D. Provide a pork chop island on the north east side of the 134 Street/Stony Plain Road intersection.
- E. Curb and gutter along the north side of Stony Plain Road, adjacent to the outbound platform of the Glenora stop shall comply with drawing #5023 in the *Valley Line West LRT Roadways Design and Construction Standards*.
- F. Curb and gutter along the south side of Stony Plain Road, adjacent to the inbound platform of the Glenora stop shall comply with drawing #5023 in the *Valley Line West LRT Roadways Design and Construction Standards*.
- G. Provide SUPs and sidewalks as specified in Table 3-2.11.8 [*Stony Plain Road (139 Street to 121 Street) SUP Requirements*].

Table 3-2.11.8 Stony Plain Road (139 Street to 121 Street) SUP/Sidewalk Requirements

Road	From	To	Side	Minimum Boulevard Width	Minimum Sidewalk/SUP Width	Notes
Stony Plain Road	~65 m west of 138 Street	138 Street	South	N/A	2.30 m monowalk	
Stony Plain Road	139 Street	138 Street	North	2.25 m	1.80 m walk	
Stony Plain Road	138 Street	137 Street	North	N/A	1.80 m monowalk	
Stony Plain Road	138 Street	136 Street	South	N/A	1.70 m monowalk	
Stony Plain Road	137 Street	~55 m east of 137 Street	North	N/A	2.30 m monowalk	
Stony Plain Road	~55 m east of 137 Street	136 Street	North	2.00 m	1.80 m walk	
Stony Plain Road	136 Street	~45 m west of 135 Street	North	1.20 m	1.50 m walk	
Stony Plain Road	~45 m west of 135 Street	135 Street	North	N/A	1.80 m monowalk	
Stony Plain Road	136 Street	135 Street	South	2.00 m	1.80 m walk	
Stony Plain Road	135 Street	~45m west of 134 Street	North	2.00 m	2.30 m walk	
Stony Plain Road	~45m west of 134 Street	134 Street	North	N/A	2.30 m monowalk	
Stony Plain Road	135 Street	134 Street	South	N/A	~3.00 m monowalk	Full width walk to property line
Stony Plain Road	134 Street	~30 m west of 133 Street	North	2.00 m	Concrete Plaza the full width between the 2.00 m boulevard and the turnaround behind	2.00 m boulevard along south side of plaza from curb ramp at 134 Street to curb ramp at 133 Street
Stony Plain Road	~30 m west of 133 Street	133 Street	North	2.00 m	1.80 m walk	
Stony Plain Road	134 Street	133 Street	South	2.25 m	1.80 m walk	

Road	From	To	Side	Minimum Boulevard Width	Minimum Sidewalk/SUP Width	Notes
Stony Plain Road	133 Street	132 Street	North	N/A	2.30 m monowalk	
Stony Plain Road	133 Street	132 Street	South	N/A	3.80 m monowalk	
132 Street	Stony Plain Road	104 Avenue	West	~3.00 m	1.50 m walk	
Stony Plain Road	132 Street	~45 m east of 132 Street	North	2.50 m	1.80 m walk	
Stony Plain Road	~45 m east of 132 Street	131 Street (Glenora Crescent)	North	N/A	2.30 m monowalk	
Stony Plain Road	132 Street	Glenora Crescent	South	1.60 m	1.80 m walk	
Stony Plain Road	131 Street	~20 m west of Groat Road	North	2.25 m	1.80 m walk	
Stony Plain Road	Glenora Crescent	~25 m east of Glenora Crescent	South	N/A	2.30 m monowalk	
Stony Plain Road	~25 m east of Glenora Crescent	Connaught Drive	South	N/A	1.60 m monowalk	
Stony Plain Road	west end of Stony Plain Road Bridge (~20 m west of Groat Road)	east end of Stony Plain Road Bridge (~50 m west of 129 Street)	North	N/A	4.05 m walk	This is walk along north side of Stony Plain Road Bridge.
North greenspace corridor	Stony Plain Road	Alley between 129 and 130 Street	N/A	N/A	2.00 m walk	Walk connection through greenspace east of bridge over Groat Road, connecting to alley in between 129 Street and 130 Street.
Stony Plain Road	~50 m west of 129 Street	129 Street	North	2.25 m	1.80 m walk	
Stony Plain Road	Connaught Drive	129 Street	South	N/A	4.20 m mono SUP	4.20 m SUP from Connaught Drive to crosswalk across Stony Plain Road on west side of 129 Street, including along south side of Stony Plain Road Bridge.
Stony Plain Road	129 Street	127 Street	South	2.40 m	3.00 m SUP	

Road	From	To	Side	Minimum Boulevard Width	Minimum Sidewalk/SUP Width	Notes
Stony Plain Road	129 Street	128 Street	North	N/A	1.50 m monowalk	
Stony Plain Road	~30 m east of 128 Street	127 Street	North	2.40 m	1.80 m walk	West end of walk ties in to existing north walk (between 128 Street to 127 Street).
105 Avenue	127 Street	Tie in to existing	North/ South	~2.65 m / N/A	~1.50 m walk / ~2.00m monowalk	Tie existing walks in to new curb ramps on NE and SE corners of 105 Avenue & 127 Street
Stony Plain Road	127 Street	~25 m west of 126 Street	North	N/A	1.50m monowalk	
Stony Plain Road	~25 m west of 126 Street	126 Street	North	N/A	Varies, ~4.40-4.80 m monowalk	
Stony Plain Road	127 Street	126 Street	South	N/A	1.80 m monowalk	
Stony Plain Road	126 Street	~35 m west of 125 Street	North	N/A	1.50 m monowalk	
Stony Plain Road	~35 m west of 125 Street	124 Street	North	2.25 m	1.80 m monowalk	
Stony Plain Road	126 Street	125 Street	South	N/A	1.50 m monowalk	
Stony Plain Road	125 Street	~30 m east of 125 Street	South	N/A	~5.60 m monowalk	
Stony Plain Road	~30 m east of 125 Street	~40 m west of 124 Street	South	N/A	~2.00 m monowalk	
Stony Plain Road	~40 m west of 124 Street	124 Street	South	N/A	~5.70 m monowalk	
Stony Plain Road	124 Street	123 Street	North	N/A	5.00m monowalk	Tie ins to existing walks are less than 5.00 m wide.
Stony Plain Road	124 Street	123 Street	South	N/A	~4.80 m monowalk	
Stony Plain Road	123 Street	122 Street	North	N/A	5.00m monowalk	Reduced width to property line at 123 Street.
Stony Plain Road	123 Street	122 Street	South	N/A	1.50 m monowalk	
Stony Plain Road	122 Street	121 Street	North	N/A	1.50 m monowalk	

Road	From	To	Side	Minimum Boulevard Width	Minimum Sidewalk/SUP Width	Notes
Stony Plain Road	122 Street	121 Street	South	N/A	5.00 m monowalk	

- H. The LRT Corridor is constrained on the north side of the crosswalk between 122 Street and 121 Street. Provide a custom design for the traffic signals pole and base that will fit within the 0.6 m margin available behind the sidewalk in this location.
- I. Provide cycle crossing facilities for the north/south movements at the 136 Street intersection in accordance with Section 6-4.3.5.3 [*Bike Signals and Detection*] of this Schedule.
- J. Provide cycle crossing facilities for the north/south movements at the 121 Street intersection in accordance with Section 6-4.3.5.3 [*Bike Signals and Detection*] of this Schedule.
- K. Road Closures, Access Closures and Connection Removals along Stony Plain Road (139 Street to 121 Street) shall be as shown on Figures 5-3A-29 to 5-3A-36 of Appendix 5-3A [*Access and Road Closure Drawings*] of this Schedule.
- L. For Connection Removal 132-P as shown as on Figure 5-3A-33 of Appendix 5-3A [*Access and Road Closure Drawings*] of this Schedule, Glenora Pointe shall be closed to vehicular traffic at Stony Plain Road once the new service road detailed in Section 3-2.11.8B [*Stony Plain Road (139 Street to 121 Street)*] of this Schedule is constructed and open to traffic.
- M. Provide a new north-south alley between 102 Avenue and the existing east-west alley south of Stony Plain Road and west of 138 Street. The new alley shall be located through 13814 102 Avenue and shall be 6 m wide on the straight and a minimum of 3.5 m wide through the bend. The new section of alley shall be one way from east end of the existing alley to 102 Avenue, with traffic permitted to travel only westwards and southwards.
- N. Provide a new east-west alley between 131 Street and the existing north-south alley north of Stony Plain Road and east of 131 Street. This new alley shall be located through Samuel Dickson Rotary Park and shall be 6 m wide.
- O. Provide a retaining wall as required at the back of the SUP on the south east approach to the Stony Plain Road Bridge where the requirements of 3-2.4.7 [*Slopes*] of this Schedule cannot be met.
- P. Approximately 2 m of sidewalk on the south side of Stony Plain Road between 123 Street and the alley east of 123 Street shall be constructed over the northeast corner of an underground parkade belonging to the adjacent property. The parkade was surveyed from the outside using hydrovac and inside and this information is provided in the Disclosed Data. Appropriate measures shall be taken to protect the parkade from physical or water damage, and:
 - 1. modification of the parkade is prohibited;
 - 2. the finished grade behind the back of walk over the parkade shall be the same or lower than the existing grade to avoid increasing the weight of soil on the parkade;
 - 3. design of the adjacent alley access onto Stony Plain Road shall prevent vehicles from driving over the corner of the parkade; and
 - 4. if any portion of the sidewalk must be constructed over the parkade, the sidewalk shall be designed and constructed to avoid differential settlements between that section and the adjacent sections of sidewalk, which are supported on grade.
- Q. The existing perpendicular parking along the west side of 134 Street north of Stony Plain Road shall be replaced with parallel parking.

3-2.11.9 104 Avenue (121 Street to 105 Street)

- A. 104 Avenue (121 Street to 105 Street) shall be as shown on Figures 5-1A-36 to 5-1A-41 of Appendix 5-1A [*Project Description Drawings*] in Part 1 [*General*] of this Schedule.

- B. The existing roadways and sidewalks east of 106 Street shall be retained with the exception of the following section:
 - 1. The westbound right-hand lane is to be removed between 105 Street and 106 Street.
- C. At the 109 Street Intersection, no westbound to southbound left turn shall be provided.
- D. Provide SUPs and sidewalks as specified in Table 3-2.11.9 (*104 Avenue (121 Street to 105 Street) SUP Requirements*).

Table 3-2.11.9 104 Avenue (121 Street to 105 Street) SUP/Sidewalk Requirements

Road	From	To	Side	Minimum Boulevard Width	Minimum Sidewalk/SUP Width	Notes
104 Avenue	121 Street	120 Street	North	N/A	2.65 m mono SUP	
104 Avenue	121 Street	120 Street	South	2.25m	1.80 m walk	
104 Avenue	120 Street	118 Street	North	N/A	6.00 m mono SUP	
104 Avenue	120 Street	119 Street	South	N/A	2.30 m monowalk	
104 Avenue	119 Street	118 Street	South	2.25m	1.80 m walk	
104 Avenue	118 Street	112 Street	North	N/A	2.30 m monowalk	
116 Street	104 Avenue	~30 m north of 104 Avenue	East	N/A	2.05 m monowalk	Monowalk to continue north around corner for ~30 m and tie into existing.
104 Avenue	118 Street	117 Street	South	N/A	2.30 m monowalk	
104 Avenue	117 Street	116 Street	South	N/A	4.05 m monowalk	
104 Avenue	116 Street	111 Street	South	N/A	2.30 m monowalk	Monowalk continues through islands along this stretch.
104 Avenue	~20 m east of 112 Street	~75 m east of 112 Street	North	N/A	2.30 m monowalk	Tie into existing plaza at 112 Street
104 Avenue	~75 m east of 112 Street	East of 111 Street curb ramp	North	N/A	Varies, tie into existing sidewalk plaza	
104 Avenue	110 Street	105 Street	North	Existing Boulevard varies	N/A – tie in curb ramps to existing sidewalk plazas	Tie into existing sidewalk plazas at each corner around curb ramps; walks and boulevards along this stretch remain as existing.
104 Avenue	111 Street	109 Street	South	N/A	1.75 m monowalk	
104 Avenue	109 Street	~50 m east of 109 Street	South	N/A	~3.00 m monowalk	
104 Avenue	~50 m east of 109 Street	108 Street	South	N/A	2.00 m monowalk	
104 Avenue	108 Street	~45 m west of 107 Street	South	N/A	~2.90 m monowalk	
104 Avenue	~45 m west of 107 Street	107 Street	South	N/A	5.00 m monowalk	

- E. Provide cycle crossing facilities for the north/south movements at the 110 Street intersection in accordance with Section 6-4.3.5.3 [*Bike Signals and Detection*] of this Schedule.
- F. Provide cycle crossing facilities for the north/south movements at the 106 Street intersection in accordance with Section 6-4.3.5.3 [*Bike Signals and Detection*] of this Schedule.
- G. Road Closures, Access Closures and Connection Removals along 104 Avenue (121 Street to 105 Street) shall be as shown on Figures 5-3A-26 to 5-3A-41 of Appendix 5-3A [*Access and Road Closure Drawings*] of this Schedule, except:
 - 1. The access to MacEwan University on the north side of 104 Avenue opposite 108 Street is in the process of being closed off by University. Provide a continuous curb, sidewalk and boulevard through this location as shown on Figure 5-1A-40 of Appendix 5-1A [*Project Description Drawings*] in Part 1 [*General*] of this Schedule. The notice period set out in Section 3-2.11.1.Q [*General Requirements*] of this Schedule shall not apply for this access.
- H. Relocate the access to 11215 – 104 Avenue (Longstreet Shopping) at 114 Street approximately 4 m east so it aligns with 114 Street north of the intersection.
- I. Provide a complete retaining wall system at the back of the sidewalk along the north side of 104 Avenue between 118 Street and 114 Street where the requirements of 3-2.4.7 [*Slopes*] cannot be met. The retaining walls shall continue outside of the City Lands at the accesses and side roads as required to tie in to existing grades. Reinstate all existing pedestrian connections or as directed by the City.

3-2.11.10 107 Street (104 Avenue to 102 Avenue)

- A. 107 Street (104 Avenue to 102 Avenue) shall be as shown on Figures 5-1A-40 and 5-1A-42 of Appendix 5-1A [*Project Description Drawings*] in Part 1 [*General*] of this Schedule.
- B. Between 103 Avenue and 102 Avenue provide a bi-directional travel lane to the west of the northbound lane for exclusive use by Emergency Services.
- C. There shall be no curb and gutter between the Trackway and the bi-directional Emergency Services travel lane to the west of the northbound lane. This area shall be for exclusive use by Emergency Services. The Roadway shall be flush with the Trackway.
- D. Curb and gutter along the east side of 107 Street, adjacent to the platforms of the NorQuest Stop shall comply with drawing #5023 in the *Valley Line West LRT Roadways Design and Construction Standards*.
- E. Curb and gutter along the west side of 107 Street between the Trackway and the sidewalk shall comply with drawing #5023 or #5024 in the *Valley Line West LRT Roadways Design and Construction Standards*. It may be varied by street block in order to achieve allowable crossfalls.
- F. Provide SUPs and sidewalks as specified in Table 3-2.11.10 (*107 Street (104 Avenue to 102 Avenue) SUP Requirements*).

Table 3-2.11.10 107 Street (104 Avenue to 102 Avenue) SUP/Sidewalk Requirements

Road	From	To	Side	Minimum Boulevard Width	Minimum Sidewalk/SUP Width	Notes
107 Street	104 Avenue	north end of NorQuest Stop Platform	West	N/A	4.85 m monowalk	Monowalk on west side of 107 Street ends at the north end of the NorQuest Stop Platform.
107 Street	104 Avenue	103 Avenue	East	N/A	Monowalk varies	Full width walk to property line
107 Street	103 Avenue	102 Avenue	West	N/A	Monowalk varies	Full width walk to property line
107 Street	103 Avenue	102 Avenue	East	N/A	3.80 m monowalk	Full width walk to property line

- G. Road Closures, Access Closures and Connection Removals along 107 Street (104 Avenue to 102 Avenue) shall be as shown on Figures 5-3A-40 and 5-3A-42 of Appendix 5-3A *[Access and Road Closure Drawings]* of this Schedule.
- H. For Access Closures 139-Q and 139-R as shown on Figure 5-3A-40 of Appendix 5-3A *[Access and Road Closure Drawings]* of this Schedule, provide the City 12 months' advance Notice prior to the closure of these accesses. Closure of these two accesses shall not be permitted until construction work to reconfigure the adjacent parking lot and drive-through has been completed by Other Contractors.

3-2.11.11 102 Avenue (107 Street to 102 Street)

- A. 102 Avenue (107 Street to 102 Street) shall be as shown on Figures 5-1A-42 to 5-1A-44 of Appendix 5-1A *[Project Description Drawings]* in Part 1 *[General]* of this Schedule.
- B. There are various constraints with fixed elevations along the 102 Avenue corridor including property lines, building features such as doorways and windows, and utilities such as vault covers. These features are identified on Figures 5-3B-01 to 5-3B-05 of Appendix 5-3B *[102 Avenue Grading Constraints Drawings]* of this Schedule. Design elevations and grading on 102 Avenue between 107 Street and 103 Street shall tie in with these features along this section of road while meeting the requirements identified in this Schedule.
- C. Set design elevations and grading such that the back of the north Platform at Alex Decoteau Stop integrates with the Alex Decoteau Park in accordance with Sections 2-10.3.4 *[Alex Decoteau Stop]* and 2-14.10.3 *[Alex Decoteau Park]* of this Schedule.
- D. Curb and gutter along the north side of 102 Avenue between the trackway and the sidewalk shall comply with drawing #5023 or #5024 in the *Valley Line West LRT Roadways Design and Construction Standards*. It may be varied by street block in order to achieve allowable crossfalls.
- E. The eastbound traffic lane shall be located immediately adjacent to the Trackway except west of 106 Street and east of 102 Street where it shall deviate southwards to allow space for the Alex Decoteau stop and to tie in with the Valley Line LRT Stage 1 alignment respectively.
- F. Provide two way on-street bike lanes along the south side of 102 Avenue. The bike lanes shall be:
 - 1. a minimum of 1.5 m wide in each direction;
 - 2. at sidewalk level between 107 Street and 105 Street and separated from the sidewalk by a 0.6 m wide shy-way delineated by flush concrete header, consistent with sections of the 102 Avenue bike lanes to the east of the Lands; and
 - 3. at roadway level between 105 Street and 102 Street and separated from the roadway by a 0.6 m wide shy-way delineated by green flexible bollards, consistent with sections of the 102 Avenue bike lanes to the west of the Lands.
- G. Along the south side of 102 Avenue between 105 Street and the alley west of 105 Street provide a 150mm high slab-on curb at the back of the sidewalk.
- H. Provide SUPs and sidewalks as specified in Table 3-2.11.11 *[102 Avenue (107 Street to 102 Street) SUP/ Sidewalk Requirements]*.

Table 3-2.11.11 102 Avenue (107 Street to 102 Street) SUP/Sidewalk Requirements

Road	From	To	Side	Minimum Boulevard Width	Minimum Sidewalk/SUP Width	Notes
102 Avenue	107 Street	102 Avenue Station	North	N/A	Monowalk varies	Full width walk to property line
102 Avenue	107 Street	105 Street	South	N/A	Monowalk varies	Full width walk to property line. Includes two way-bike lanes
102 Avenue	105 Street	102 Avenue Station	South	N/A	Monowalk varies	Full width walk to property line

- I. Provide cycle crossing facilities for the north/south movements at the 106 Street intersection.
- J. Provide cycle crossing facilities for the north/south movements at the 103 Street intersection.
- K. Road Closures, Access Closures and Connection Removals along 102 Avenue (107 Street to 102 Street)) shall be as shown on Figures 5-3A-41 to 5-3A-43 of Appendix 5-3A [*Access and Road Closure Drawings*] of this Schedule.
- L. Provide a turnaround at the south end of the alley north of 102 Avenue between 107 Street and 106 Street before implementing Connection Removal 140-K as shown on Figure 5-3A-42 of Appendix 5-3A [*Access and Road Closure Drawings*] of this Schedule. This turnaround shall comply with the Standard Alley Offset Turnaround from drawing #3040 in the *Valley Line West LRT Roadways Design and Construction Standards*, and shall be located on the west side of the alley.
- M. Provide a turnaround at the south end of the alley north of 102 Avenue between 106 Street and 105 Street before implementing Connection Removal 141-E as shown on Figure 5-3A-43 of Appendix 5-3A [*Access and Road Closure Drawings*] of this Schedule. This turnaround shall comply with the Standard Alley Cul-de-sac from drawing #3040 in the *Valley Line West LRT Roadways Design and Construction Standards*, with the smaller area located on the west side of the alley and the larger area on the east. Integrate the turnaround with the Alex Decoteau Park in accordance with Section 2-14.10.3 [*Alex Decoteau Park*] of this Schedule.
- N. Provide a turnaround at the south end of the alley north of 102 Avenue and east of 105 Street before implementing Connection Removal 141-J as shown on Figure 5-3A-43 of Appendix 5-3A [*Access and Road Closure Drawings*] of this Schedule. This turnaround shall comply with the Standard Alley Offset Turnaround from drawing #3040 in the *Valley Line West LRT Roadways Design and Construction Standards*, and shall be located on the west side of the alley.
- O. Integration of the Roadways with the Valley Line LRT Stage 1 shall be in accordance with Section 1-1.4 [*Integration with Valley Line LRT Stage 1*] of this Schedule.
- P. For Connection Removal 140-K as shown on Figures 5-3A-42 of Appendix 5-3A [*Access and Road Closure Drawings*] of this Schedule, provide the City 12 months' advance Notice prior to the removal of this access. Removal of this access shall not be permitted until construction work to reconfigure the adjacent parking lot has been completed by Other Contractors.
- Q. For Connection Removal 141-E and Access Closure 141-D as shown on Figures 5-3A-43 of Appendix 5-3A [*Access and Road Closure Drawings*] of this Schedule, provide the City 12 months' advance Notice prior to the removal and closure at these locations. Closure of access 141-D shall not be permitted until construction work to reconfigure the adjacent parking lot and New Access 141-O has been completed by Other Contractors.

3-2.11.12 Gerry Wright OMF Site

- A. Access roads to and within the Gerry Wright OMF Site shall be in accordance with the requirements of Section 8-2.5.4 [*Site Access*] of this Schedule and:
 - 1. the design vehicles for the access roads to and within the Gerry Wright OMF Site shall be a WB-21 as defined in *TAC Geometric Design Guide for Canadian Roads* and a City of Edmonton Waste Collection Truck as defined in the *Valley Line West LRT Roadways Design and Construction Standards*;
 - 2. the minimum pavement structure for the access roads for the Gerry Wright OMF Site shall be as specified for the access road with truck traffic in Table 3-4.3.11 [*Minimum Pavement Structures (Lewis Farms Park and Ride)*] of this Schedule; and

3. access roads to and within the Gerry Wright OMF Site shall be constructed in accordance with Section 3-2.4 *[Geometric Design]* of this Schedule.
- B. Parking for the Gerry Wright OMF Site shall be in accordance with the requirements of Section 8-2.5.5 *[Parking Facilities]* of this Schedule and:
1. parking layouts shall meet the requirements of City of Edmonton Bylaw 12800 Clauses 54.2 and 54.4; and
 2. the minimum pavement structure for the parking facilities for the Gerry Wright OMF Site shall be as specified for the asphalt parking area in Table 3-4.3.11 *[Minimum Pavement Structures (Lewis Farms Park and Ride)]* of this Schedule.

3-2.11.13 Lewis Farms Storage Facility

- A. Access roads to and within the Lewis Farms Storage Facility site shall be in accordance with the requirements of Section 8-3.5.4 *[Site Access]* of this Schedule and:
1. the design vehicle for the access roads to Lewis Farms Storage Facility shall be an MSU as defined in *TAC*;
 2. the minimum pavement structure for the access roads for the Lewis Farms Storage Facility shall be as specified for the access road with truck traffic in Table 3-4.3.11 *[Minimum Pavement Structures (Lewis Farms Park and Ride)]* of this Schedule; and
 3. access roads to and within the Lewis Farms Storage Facility shall be constructed in accordance with Section 3-2.4 *[Geometric Design]* of this Schedule.
- B. Parking for the Lewis Farms Storage Facility shall be in accordance with the requirements of Section 8-3.5.5 *[Parking Facilities]* of this Schedule and:
1. parking layouts shall meet the requirements of City of Edmonton Bylaw 12800 Clauses 54.2 and 54.4; and
 2. the minimum pavement structure for the parking facilities for the Lewis Farms Storage Facility shall be as specified for the asphalt parking area in Table 3-4.3.11 *[Minimum Pavement Structures (Lewis Farms Park and Ride)]* of this Schedule.

Section 3-3 WEST EDMONTON MALL TRANSIT CENTRE

3-3.1 SCOPE

- A. This Section 3-3 [*West Edmonton Mall Transit Centre*] sets out the civil site development requirements for the West Edmonton Mall Transit Centre, including the requirements for the horizontal and vertical alignments of the busways and Passenger loading platforms and crosswalks.

3-3.2 DESIGN BASIS AND CRITERIA

3-3.2.1 Design Standards

- A. Without limiting Section 1-1.7 [*Reference Documents*] of this Schedule and except as otherwise specified herein, the civil site development requirements for the West Edmonton Mall Transit Centre and all associated infrastructure shall comply with the requirements of the following codes, standards and regulations:
1. Valley Line West LRT Roadways Design and Construction Standards;
 2. ETS Transit Centre Design Guidelines;
 3. City of Edmonton Access Design Guide;
 4. TAC "*Geometric Design Guide for Canadian Roads*";
 5. Age Friendly Edmonton Access Design Guide; and
 6. NBCAE.
- B. In the event of any conflict, ambiguity or inconsistency between or among the requirements of the above listed codes, standards and regulations, the requirements shall apply in the order listed in Section 3-3.2.1A [*Design Standards*] of this Schedule.

3-3.2.2 General Requirements

- A. The West Edmonton Mall Transit Centre shall be as shown on Figure 5-1A-45 of Appendix 5-1A [*Project Description Drawings*] in Part 1 [*General*] of this Schedule.
- B. The West Edmonton Mall Transit Centre shall include:
1. the WEM Central Passenger Loading Area;
 2. the WEM North Passenger Loading Area;
 3. the WEM South Passenger Loading Area;
 4. a minimum of twelve (12) sawtooth-style bus bays, of which two (2) shall be configured for City of Edmonton Articulated Buses and ten (10) shall accommodate City of Edmonton Buses and City of Edmonton Electric Buses, each as defined in Section 3-3.2.3 [*Design Vehicles*] of this Schedule. These bus bays shall be laid out as shown on Figure 5-1A-45 of Appendix 5-1A [*Project Description Drawings*] in Part 1 [*General*] of this Schedule; and
 5. a minimum of three (3) roadside articulated bus bays on the north side of 87 Avenue.
- C. The WEM Central Passenger Loading Area shall be integrated with the West Edmonton Mall Station and shall be located beneath the portion of the 87 Avenue Elevated Guideway.

- D. The existing fence along the south edge of the West Edmonton Mall Transit Centre south passenger loading area shall be removed in accordance with Section 1-7.5.4.1A [Existing WEM Transit Centre] of this Schedule and shall not be replaced.

3-3.2.3 Design Vehicles

A. Design vehicles for the West Edmonton Mall Transit Centre shall be:

1. City of Edmonton bus, as defined in Figure 3-3.2.3-1 [City of Edmonton Bus Profile];
2. City of Edmonton articulated bus, as defined in Figure 3-3.2.3-2 [City of Edmonton Articulated Bus Profile];
3. City of Edmonton electric bus, as defined in Figure 3-3.2.3-3 [City of Edmonton Electric Bus Profile];
4. DATS Buses;
5. City of Edmonton fire truck as defined the *Valley Line West LRT Roadways Design and Construction Standards*; and

B. an additional 1.2 m shall be added to the front overhang shown in Figure 3-3.2.3-1 [City of Edmonton Bus Profile], Figure 3-3.2.3-2 [City of Edmonton Articulated Bus Profile] and Figure 3-3.2.3-3 [City of Edmonton Electric Bus Profile] to allow for an extended bike rack.

C. The width of the buses defined in Figure 3-3.2.3-1 [City of Edmonton Bus Profile], 3-3.2.3-2 [City of Edmonton Articulated Bus Profile] and Figure 3-3.2.3-3 [City of Edmonton Electric Bus Profile] shall be increased to 3.15m to include the wing mirrors.

Figure 3-3.2.3-1 City of Edmonton Bus Profile

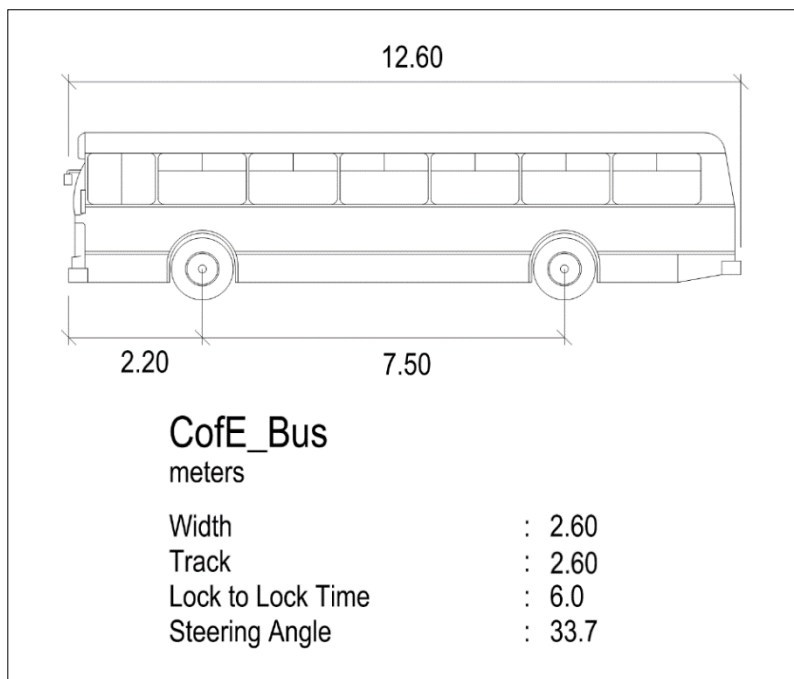

Figure 3-3.2.3-2 City of Edmonton Articulated Bus Profile

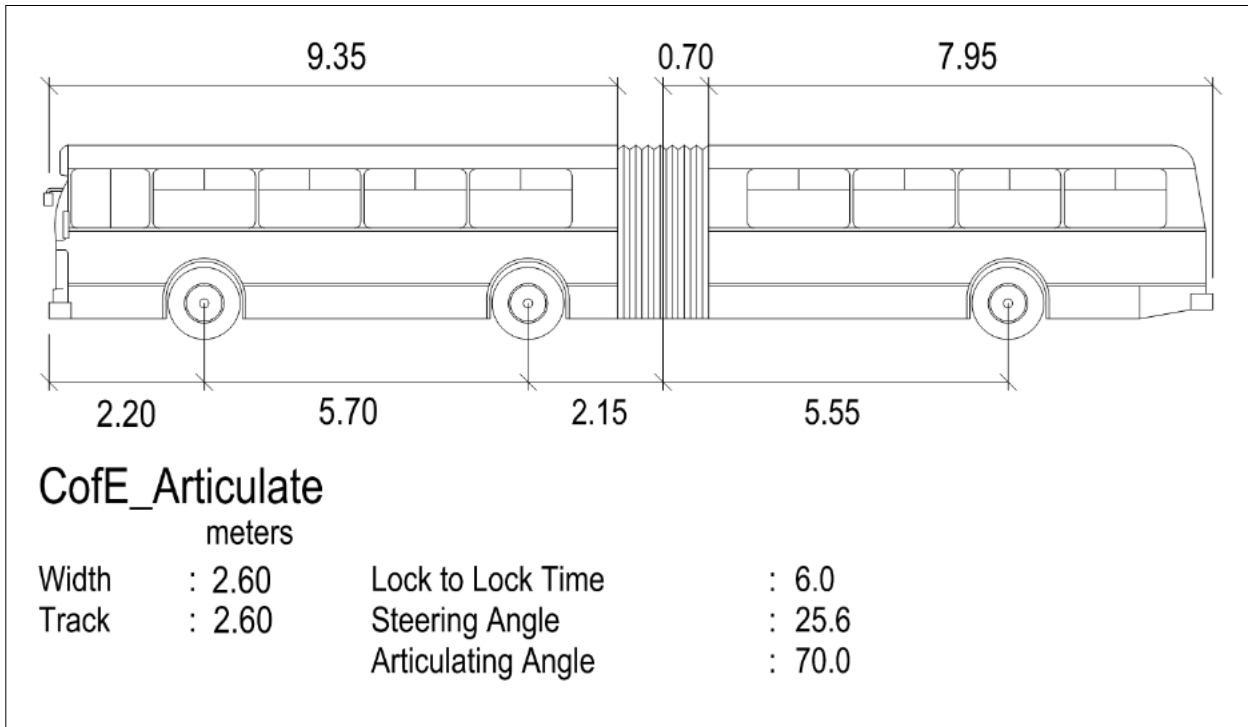
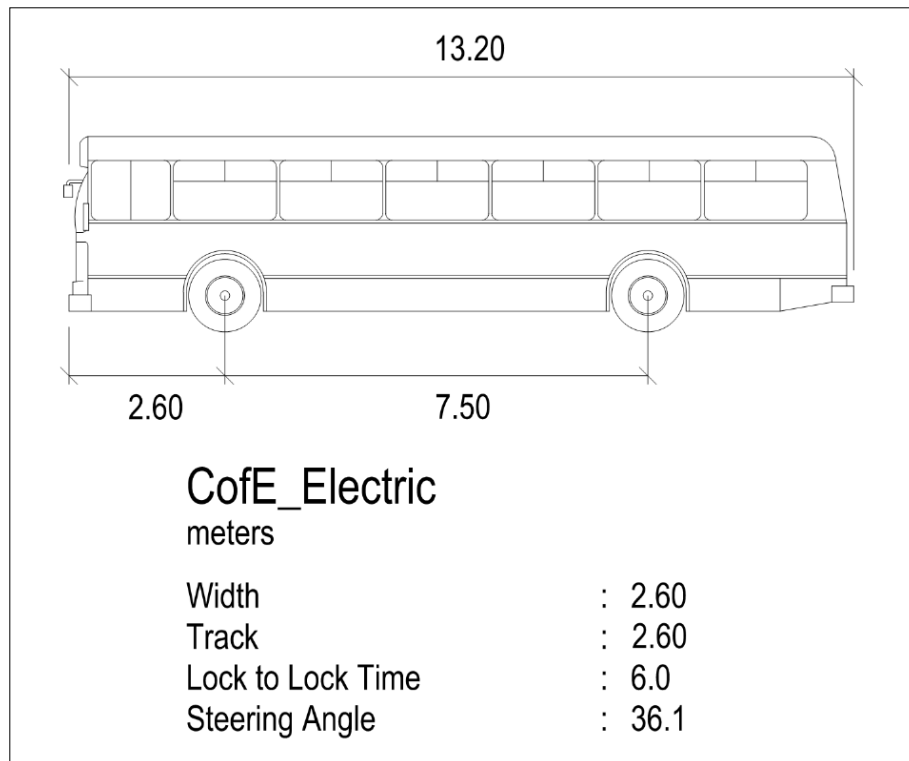

Figure 3-3.2.3-3 City of Edmonton Electric Bus Profile



3-3.3 DESIGN SPECIFIC REQUIREMENTS

3-3.3.1 West Edmonton Mall Transit Centre Busway

- A. The West Edmonton Mall Transit Centre busway layout shall be such that any combination of design vehicles can maintain two-way circulation through the north aisle of the West Edmonton Mall Transit Centre and one-way westbound circulation through the south aisle of the West Edmonton Mall Transit Centre, with all bus bays occupied by the design vehicle buses. There shall be no conflicting movements when travelling in opposite directions, including entering and leaving bus stop areas.
- B. All bus bays shall operate independently and shall be accessible to buses (in and out) regardless of the occupancy of any adjacent bays. All buses parked in a bus bay shall be accessible for safe loading and unloading of passengers, with rear doors as well as front doors against a curb.
- C. The busway design shall accommodate the turning path, sight distance, and clearance envelope requirements for all West Edmonton Mall Transit Centre design vehicles.
- D. Curb return radii shall accommodate all design vehicle minimum inside turning radii and allow simultaneous two-way design vehicle bus movements without lane encroachment.
- E. Due to the constrained nature of the WEM Transit Centre, the busway may be narrower than prescribed in the ETS Transit Centre Design Guidelines provided a swept path analysis demonstrates that the requirements of this Section 3-3.3.1 [*West Edmonton Mall Transit Centre Busway*] can be met.

3-3.3.2 Passenger Loading Platforms

- A. Passenger loading platforms refer to the areas adjacent to and connecting between the bus bays for passenger loading and unloading.
- B. Passenger loading platforms in the WEM North Passenger Loading Area and the WEM South Passenger Loading Area shall be constructed of concrete and each shall have a minimum clear width of 3.0 m from the back of the platform curbs along at least the length of the applicable design vehicle bus, as specified in Section 3-3.2.3 [*Design Vehicles*] of this Schedule. Any permanent obstructions or structures (including light standards, benches, shelters, landscape features, gas meters and other utilities) that could interfere with the loading or unloading of bus passengers, including those with wheelchairs, scooters and other mobility aids using buses or DATS vehicles with ramps deployed, shall be located outside of this clear width.
- C. Passenger loading platforms in the WEM Central Passenger Loading Area shall be constructed of concrete and shall have a minimum clear width of 1.9 m from the back of the platform curb along at least the length of the applicable design vehicle bus, as specified in Section 3-3.2.3 [*Design Vehicles*] of this Schedule. Any permanent obstructions or structures (including light standards, benches, shelters, landscape features, gas meters and other utilities) that could interfere with the loading or unloading of bus passengers, including those with wheelchairs, scooters and other mobility aids using buses or DATS vehicles with ramps deployed, shall be located outside of this clear width.
- D. Sidewalks associated with each passenger loading platform shall have:
 - 1. a minimum longitudinal grade of 0.5% and a maximum of 5%; and
 - 2. a minimum crossfall of 1.5% and a maximum of 2.5%.
- E. Due to the confined area on the WEM Central Passenger Loading Area, sawtooth bus bays as shown in Figure 3-3.2.3-1 [*City of Edmonton Bus Profile*] may be 1.0 m shorter than the required length as shown in Drawing #4400 of the *Valley Line West LRT Roadways Design and Construction Standards*. Sawtooth bus bays for articulated buses may be 3 m shorter than the length of a City of Edmonton

Articulated bus as shown in Figure 3-3.2.3-2 City of Edmonton Articulated Bus Profile, provided they are the last bay on the island.

- F. Provide four (4) Vangarde 4'x16' shelters adjacent to the clear area of the passenger loading platform in the WEM North Passenger Loading Area.
- G. Connections for Wi-Fi shall be provided to all bus stops at the West Edmonton Mall Transit Centre in accordance with Section 6-1.21.2.9 [*Public Wi-Fi*] of this Schedule.

3-3.3.3 Access

- A. Provide the following dedicated bus access to West Edmonton Mall Transit Centre:
 - 1. a signalized all directional access to/from 87 Avenue / WEM Transit Centre (174 Street) at the south-east end of the West Edmonton Mall Transit Centre; and
 - 2. a 'right in-left out' access to/from the West Edmonton Mall access road (175 Street) at the west end of the West Edmonton Mall Transit Centre.

3-3.3.4 Service, Maintenance and Security Vehicle Parking

- A. Provide a minimum of three (3) parking spaces, for exclusive City use, along the north side of 87 Avenue and within 80m of the WEM Central Passenger Loading Area.
- B. The three (3) parking spaces referred to in Section 3-3.3.4A [*Service, Maintenance and Security Vehicle Parking*] of this Schedule shall:
 - 1. be designed for a Light Single Unit Truck, as defined in TAC; and
 - 2. not impede vehicle flow along 87 Avenue.
- C. Provide a clear, hard surfaced path of travel from the parking spaces to the entire West Edmonton Mall Transit Centre area to support the safe movement of equipment.

3-3.3.5 Bicycle Parking

- A. Provide Covered Bicycle Racks in accordance with Section 2-10.2.10 [*Bicycle Racks*] of this Schedule for a minimum of eighteen (18) bicycles within 50 m of an entrance to the West Edmonton Mall Station. These bicycle racks shall be grouped either all together or in a maximum of three (3) smaller groups but shall not be located on the WEM North Passenger Loading Area, the WEM Central Passenger Loading Area or the WEM South Passenger Loading Area.

3-3.3.6 Kiss and Ride

- A. Provide a Kiss and Ride facility within 100 m walking distance of the WEM Central Passenger Loading Area.
- B. The Kiss and Ride shall have a minimum capacity of four (4) parked passenger cars, as defined in TAC.
- C. The design of the Kiss and Ride shall permit vehicles to safely pass parked vehicles.
- D. The Kiss and Ride shall be designed for safe passenger drop-off on the right-hand side of the vehicle. Provide a minimum 2.5 m wide concrete surface, clear of any obstructions, for passenger drop-off.

3-3.3.7 Pedestrians

- A. Provide direct, dedicated, Barrier-Free, safe and functional pedestrian paths of travel:

1. to and from all areas of the West Edmonton Mall Transit Centre and entrances to the West Edmonton Mall Station; and
2. from the West Edmonton Mall Site to existing, adjacent, offsite pedestrian facilities, including SUPs on 87 Avenue.

B. Pedestrian corridors within the West Edmonton Mall Site shall have a minimum 2.1 m clear width.

3-3.3.8 Crosswalks

A. Provide marked crosswalks within West Edmonton Mall Transit Centre in the following locations:

1. between the WEM North Passenger Loading Area and the north side of the WEM Central Passenger Loading Area;
2. between the WEM South Passenger Loading Area and the south side of the WEM Central Passenger Loading Area;
3. between the east end of the WEM Central Passenger Loading Area and the east side of the West Edmonton Mall Site; and
4. between the south-west corner of the WEM Central Passenger Loading Area and the WEM South Passenger Loading Area adjacent to the 175 Street intersection.

B. The crosswalks shall reflect the pedestrian desire lines as closely as possible in relation to entrances to West Edmonton Mall Station, locations of bicycle parking, accesses to WEM, and locations of pedestrian crosswalks outside of the West Edmonton Mall Site.

C. Crosswalks shall be located on tangents between the bus bays. A minimum 4.0 m tangent shall be provided in the location of the crosswalks. However, this may be reduced to 2.0 m on the WEM Central Passenger Loading Area for the north and south crosswalks due to the constrained area.

D. Crosswalks within the busways shall be inlaid thermoplastic yellow zebras.

3-3.3.9 Pavement Structure

A. Provide the following pavement structure within the West Edmonton Mall Transit Centre:

1. 270 mm jointed Class A one course concrete pavement complete with dowel baskets with a maximum joint spacing of 5.0 m over 300 mm 3-20mm Granular Base Course over 150 mm Cement Stabilized Subgrade.

3-3.3.10 Curbs, Gutters, Medians and Sidewalks

A. All curbs, gutters, medians and sidewalks within the West Edmonton Mall Site shall comply with the applicable requirements of the *Valley Line West LRT Roadways Design and Construction Standards*.

B. All curbs and gutters should be constructed monolithically when attached to a platform or sidewalk.

3-3.3.11 Pavement Marking and Signage

A. Design and install all permanent pavement markings in accordance with:

1. the *Valley Line West LRT Roadways Design and Construction Standards*; and
2. the *City of Edmonton Design and Construction Standards, Volume 8 – Pavement Markings*.

- B. In consultation with the City, provide all wayfinding and regulatory signs within the West Edmonton Mall Transit Centre including the following:
 - 1. signs specified in the *ETS Transit Centre Design Guidelines*; and
 - 2. crosswalk signs within the West Edmonton Mall Transit Centre, which shall have luminous sleeves.
- C. All ETS bus route signs shall be designed, supplied and installed by the City, in accordance with Section 1-1.3 [*City Works*] of this Schedule.

Section 3-4 LEWIS FARMS PARK AND RIDE

3-4.1 SCOPE

- A. This Section 3-4 [*Lewis Farms Park and Ride*] sets out the civil site development requirements for the Lewis Farms Park and Ride, including the requirements for the horizontal and vertical alignments of the parking lots, sidewalks, and Shared Use Paths.

3-4.2 DESIGN BASIS AND CRITERIA

3-4.2.1 Design Standards

- A. Without limiting Section 1-1.7 [*Reference Documents*] of this Schedule and except as otherwise specified herein, the civil site development requirements for the Lewis Farms Park and Ride and all associated infrastructure shall comply with the requirements of the following codes, standards and regulations:
1. Valley Line West LRT Roadways Design and Construction Standards;
 2. City of Edmonton Bylaw 12800;
 3. AASHTO Guide for Park and Ride Facilities;
 4. City of Edmonton Access Design Guide;
 5. TAC "*Geometric Design Guide for Canadian Roads*";
 6. Age Friendly Edmonton Access Design Guide; and
 7. NBCAE.
- B. In the event of any conflict, ambiguity or inconsistency between or among the requirements of the above listed codes, standards and regulations, the requirements shall apply in the order listed in Section 3-3.2.1A [*Design Standards*] of this Schedule.

3-4.2.2 General Requirements

- A. The Lewis Farms Park and Ride shall be as shown on Figure 5-1A-46 of Appendix 5-1A [*Project Description Drawings*] in Part 1 [*General*] of this Schedule
- B. The Lewis Farms Park and Ride shall include:
1. the Lewis Farms Stop;
 2. permanent asphalt parking areas;
 3. a temporary gravel parking area;
 4. associated access roads, sidewalks and SUPs; and
 5. vehicular access to the Lewis Farms Storage Facility.
- C. No alterations shall be made to the Lewis Farms Transit Centre with the following exceptions:
1. reconstruction of the south sidewalk of the Lewis Farms Transit Centre as required to tie into the Lewis Farms Stop and Trackway.

- D. The Lewis Farms Transit Centre shall remain fully functional during the Construction Period in accordance with Section 1-3.1.3 [*Lewis Farms Transit Centre and Park and Ride*] of this Schedule

3-4.2.3 Design Vehicles

- A. The design vehicle for the Lewis Farms Park and Ride, including the Kiss and Ride, shall be a passenger car, as defined in *TAC*.
- B. Notwithstanding the requirement of Section 3-4.2.3A [*Design Vehicles*] of this Schedule, the design vehicles for the access road to the Lewis Farms Storage Facility shall include a Medium Single Unit Truck, as defined in *TAC* and a City of Edmonton Waste Collection Truck as defined in the *Valley Line West LRT Roadways Design and Construction Standards*.
- C. Notwithstanding the requirement of Section 3-4.2.3A [*Design Vehicles*] of this Schedule, the design vehicle for the emergency access route from the north end of Potter Greens Drive near Christopher Cruz Park shall be a City of Edmonton fire truck as defined the *Valley Line West LRT Roadways Design and Construction Standards*.

3-4.3 DESIGN SPECIFIC REQUIREMENTS

3-4.3.1 Lewis Farms Park and Ride Requirements

- A. Provide no fewer than 892 passenger vehicle parking stalls. Stalls shall be designated for specific uses as follows, with the remainder being regular parking stalls:
1. twelve (12) parking stalls shall be Barrier-Free stalls as described in Section 3-4.3.5 [*Barrier-Free Parking*] of this Schedule;
 2. thirty-six (36) parking stalls shall be Kiss and Ride stalls as described in Section 3-4.3.6 [*Kiss and Ride*] of this Schedule;
 3. ten (10) stalls shall be quick turnover stalls for taxis and other ride hailing services, as described in Section 3-4.3.7 [*Other Use Parking*] of this Schedule;
 4. four (4) stalls shall be made ready for electric vehicle charging, as described in Section 3-4.3.7 [*Other Use Parking*] of this Schedule; and
 5. four (4) stalls shall be multiple occupancy vehicle stalls for car pooling or parent and child patrons, as described in Section 3-4.3.7 [*Other Use Parking*] of this Schedule.
- B. Separate Lewis Farms Park and Ride parking facilities into a permanent parking lot located south and east of the Lewis Farms Transit Centre containing no fewer than 629 stalls (the “**Lewis Farms Permanent Parking Facility**”) and a gravel parking lot within the TUC on the existing gravel parking lot and extension as set out in Section 3-4.3.1.K [*Lewis Farms Park and Ride Requirements*] of this Schedule, containing no fewer than 263 stalls (the “**Lewis Farms Temporary Parking Facility**”).
- C. In addition to the requirements of Section 3-4.3.1A [*Lewis Farms Park and Ride Requirements*] of this Schedule, provide an additional asphalt parking area in the area bounded by Lewis Farms Transit Centre and the TUC boundary on the north side of the LRT trackway, and accessed through the Lewis Farms Transit Centre, for the following specific uses:
1. four (4) parking stalls shall be for City maintenance vehicles, for exclusive City use, as described in Section 3-4.3.3 [*Service, Maintenance and Security Vehicle Parking*] of this Schedule; and
 2. twelve (12) stalls for City staff parking, for exclusive City use, as described in Section 3-4.3.8 [*Parking for City Personnel*] of this Schedule.

- D. The stalls for the specific uses listed in Section 3-4.3.1A [*Lewis Farms Park and Ride Requirements*] of this Schedule shall be located within the Lewis Farms Permanent Parking Facility.
- E. No infrastructure required to support the operation of the Infrastructure is to be installed within the Lewis Farms Park and Ride, with the exception of infrastructure required solely for the purpose of operating the Lewis Farms Park and Ride.
- F. Provide the geometric layout of the Lewis Farms Park and Ride in accordance with City of Edmonton Bylaw 12800 to accommodate the design vehicle turning movements and in compliance with the following additional design parameters:
 - 1. dead-end drive aisles are not permitted;
 - 2. parking rows shall be oriented perpendicular to the Lewis Farms Stop; and
 - 3. vehicle circulation within the main parking areas shall be two way.
- G. Delineate parking bays within the Lewis Farms Permanent Parking Facility by cast-in-place concrete curbed landscape islands on the ends. Minimum dimensions of the islands shall be 2.0 m x 10 m, measured from face-of-curb to face-of-curb; and
 - 1. the parking lot perimeter shall be defined by cast-in-place concrete curbing.
- H. Provide delineated parking bays within the Lewis Farms Temporary Parking Facility by placement of concrete curb stops between the parking rows, with small gaps in between each unit to allow for drainage, and around the perimeter of the site, and by placement of mini barriers at the end of each parking row.
- I. Provide the following vertical layout design parameters at the Lewis Farms Permanent Parking Facility:
 - 1. minimum grade in a parking stall shall be 0.5% and a maximum grade shall be 3.0%;
 - 2. minimum grade along a curb shall be 0.5%;
 - 3. minimum longitudinal grade in the drive aisle shall be 0.5% with a maximum of 5.0%; and
 - 4. minimum crossfall in the drive aisles and access roads shall be 0.020 m/m.
- J. Provide the following vertical layout design parameters at the Lewis Farms Temporary Parking Facility:
 - 1. minimum grade in a parking stall shall be 2% and a maximum grade shall be 3.0%; and
 - 2. minimum crossfall in the drive aisles shall be 0.020 m/m.
- K. The Lewis Farms Temporary Parking Facility shall be extended southwards by up to 40 m in order to accommodate the total 263 passenger vehicle stalls in the Lewis Farms Temporary Parking Facility.

3-4.3.2 Access

- A. Maintain an all directional access to the Lewis Farms Park and Ride located at the Webber Greens Drive intersection immediately west of the Lewis Farms Transit Centre as shown on Figure 5-1A-1 of Appendix 5-1A [*Project Description Drawings*] in Part 1 [*General*] of this Schedule.

- B. Provide an access road that extends from the all directional access to the Lewis Farms Park and Ride, south along the boundary of the Muskakosi Natural Area as shown on Figures 5-1A-1 and 5-1A-46 of Appendix 5-1A [*Project Description Drawings*] in Part 1 [*General*] of this Schedule.
- C. Provide appropriate measures on the northbound lanes of the access road south of the Lewis Farms Transit Centre access to ensure that vehicles do not queue across the Lewis Farms Transit Centre access.
- D. Provide an emergency vehicle access route along a new SUP linking the south end of the Lewis Farms Park and Ride with the north end of Potter Greens Drive near Christopher Cruz Park. The pavement structure shall be designed to accommodate such use.
- E. Provide a minimum of one (1) two-way vehicular accesses between the Lewis Farms Permanent Parking Facility and the Lewis Farms Temporary Parking Facility.
- F. Provide a two-way vehicular access between the busway of the Lewis Farms Transit Centre and the additional parking area identified in Section 3-4.3.1C [*Lewis Farms Park and Ride Requirements*] of this Schedule.
- G. Provide a gated access to the TUC from the south end of the Lewis Farms Temporary Parking Facility to allow the passage of farm equipment.
- H. The posted speed on the access roads shall be 40 km/h.

3-4.3.3 Service, Maintenance and Security Vehicle Parking

- A. Provide City service, maintenance, and security parking spaces in accordance with Section 3-4.3.1C [*Lewis Farms Park and Ride Requirements*] of this Schedule, for exclusive City use, within 50 m walking distance of the Platform of the Lewis Farms Stop that shall be designed for medium single unit truck, as defined in the *Valley Line West LRT Roadways Design and Construction Standards*, and shall not impede vehicle flow around the Lewis Farms Transit Centre

3-4.3.4 Bicycle Facilities

- A. Provide Covered Bicycle Racks in accordance with Section 2-10.2.10 [*Bicycle Racks*] of this Schedule for a minimum of 60 bicycles, within 70 m walking distance of the east or west ramp at the end of the Lewis Farms Stop. The bicycle racks shall either be grouped all together or in a maximum of three (3) smaller groups. The Covered Bicycle Racks shall be located within the Lewis Farms Permanent Parking Facility.
- B. Provide a continuous 3.0 m wide boulevard SUP along the west side of the Lewis Farms Park and Ride site linking Webber Greens Drive and the north end of Potter Greens Drive near Christopher Cruz Park. The south portion of the SUP shall be designed as a route for emergency vehicles as described in Section 3-4.3.2D [*Access*] of this Schedule.
- C. Provide a 3.0 m wide boulevard SUP along the south side of the Lewis Farms Park and Ride site linking the SUP on the west side of the Lewis Farms Park and Ride site and the old 199 Street via the existing trail around the storm pond.

3-4.3.5 Barrier-Free Parking

- A. Provide a separate Barrier-Free parking area and spaces in accordance with Section 3-4.3.1A [*Lewis Farms Park and Ride Requirements*] of this Schedule, within a 70 m Barrier-Free walking distance from the east or west ramp at the end of the Lewis Farms Stop.
- B. The Barrier-Free parking shall meet the requirements of the *Age Friendly Edmonton Access Design Guide* and the *NBCAE*.

- C. Vehicle circulation through the Barrier-Free parking area shall be one way and shall only serve the Barrier-Free parking area.

3-4.3.6 Kiss and Ride

- A. Provide a separate Kiss and Ride parking area and stalls in accordance with Section 3-4.3.1A [*Lewis Farms Park and Ride Requirements*] of this Schedule, within a 70 m walking distance of the east or west pedestrian ramp at the end of the Lewis Farms Stop.
- B. All Kiss and Ride stalls shall be one-way drive through stalls.
- C. Vehicle circulation through the Kiss and Ride parking area shall be one-way and shall only serve the Kiss and Ride parking area.
- D. Provide signage to designate the Kiss and Ride for temporary parking only, with a maximum duration of 15 minutes.

3-4.3.7 Other Use Parking

- A. Provide stalls in accordance with Section 3-4.3.1A [*Lewis Farms Park and Ride Requirements*] of this Schedule, for quick turnover vehicles including taxis and other ride hailing services such as Uber within an 80 m walking distance of the east or west pedestrian ramp at the end of the Lewis Farms Stop.
- B. Provide stalls in accordance with Section 3-4.3.1A [*Lewis Farms Park and Ride Requirements*] of this Schedule, for electric vehicle charging within an 80 m walking distance of the east or west pedestrian ramp at the end of the Lewis Farms Stop. Provide the underground infrastructure to enable the future charging of electric vehicles in these stalls in accordance with Section 6-1.23 [*Electric Vehicle Charging Stations*] of this Schedule.
- C. Provide multiple occupancy vehicle stalls in accordance with Section 3-4.3.1A [*Lewis Farms Park and Ride Requirements*] of this Schedule, for car pooling or parent and child patrons within an 80 m walking distance of the east or west pedestrian ramp at the end of the Lewis Farms Stop.
- D. Provide signage for the quick turnover, electric vehicle, and multiple occupancy vehicle stalls according to their uses.

3-4.3.8 Parking for City Personnel

- A. Provide stalls in accordance with Section 3-4.3.1C [*Lewis Farms Park and Ride Requirements*] of this Schedule, for City personnel parking, for exclusive City use, in a separate parking area bounded by the Trackway to the south, the TUC to the east, Webber Greens Drive to the north and Lewis Farms Transit Centre to the west.
- B. Provide access to the parking area for City personnel from the busway within the Lewis Farms Transit Centre.

3-4.3.9 Pedestrians

- A. Provide direct, dedicated, Barrier-Free, safe and functional pedestrian paths of travel:
 - 1. to and from all areas of the Lewis Farms Park and Ride, including Barrier-Free parking, Kiss and Ride, other use parking, bicycle parking, and the Lewis Farms Stop;
 - 2. between the Lewis Farms Park and Ride and the Lewis Farms Transit Centre; and

3. from the Lewis Farms Site to existing, adjacent, offsite pedestrian facilities, including the sidewalks along Webber Greens Drive.
- B. Provide longitudinal pedestrian walkways, a minimum of 4.0 m wide, to be located between two rows of parking. Provide one walkway for every four rows of parking.
- C. Provide transverse pedestrian walkways across all rows of parking where parking bay lengths are greater than 26 stalls. Transverse pedestrian walkways shall be a minimum of 2.6 m wide.
- D. Provide pedestrian sidewalks along both sides of the access road(s) within the site unless there is an SUP or there is no pedestrian desire line in a particular location. Access road sidewalks shall be separate (boulevard) walks and shall be a minimum of 1.8 m wide. If there is insufficient boulevard width to provide trees, 3.0 m wide monolithic (curb line) sidewalks may be used.
- E. Provide two pedestrian connections between the Lewis Farms Temporary Parking Facility and the Lewis Farms Permanent Parking Facility. If a pedestrian connection is adjacent to the access road between the two parking facilities, the portion within the TUC shall be constructed from gravel and separated from the adjacent driving lanes by concrete barriers.
- F. Within the Lewis Farms Temporary Parking Facility, longitudinal, and perimeter walkways are not required. Transverse walkways shall be provided, lining up with the pedestrian connections provided in this Section 3-4.3.9E [*Pedestrians*] and shall be constructed from gravel and separated from the adjacent driving lanes by concrete barriers.
- G. Comply with Section 1-3.1.3 [*Lewis Farms Transit Centre and Park and Ride*] of this Schedule at all times during the Construction Period.
- H. All sidewalks and SUPs shall allow a clear path of travel, free of obstructions. Connecting curb ramps shall also be free of obstructions.

3-4.3.10 Crosswalks

- A. Provide raised, marked crosswalks within the Lewis Farms Park and Ride. At a minimum, crosswalks shall be provided in all locations where sidewalks or SUPs cross perimeter access roads or accesses into the parking areas.
- B. Provide curb ramps at all crosswalks. The width of the ramp shall equal the width of the adjacent walk or SUP.
- C. Where crosswalks are required within the Lewis Farms Park and Ride, they shall be white thermoplastic zebras.

3-4.3.11 Pavement Structure

- A. The minimum pavement structures for the Lewis Farms Park and Ride shall be as specified in Table 3-4.3.1 [*Minimum Pavement Structures (Lewis Farms Park and Ride)*].

Table 3-4.3.1 Minimum Pavement Structures (Lewis Farms Park and Ride)

Section	Surfacing Strategy
Asphalt parking area, including access roads without truck traffic	75 mm 10mm-HT 300 mm 3-20mm Granular Base Course 150 mm Cement Stabilized Subgrade
Access road with truck traffic	50 mm 10mm-HT 75 mm 20mm-B 300 mm 3-20mm Granular Base Course 150 mm Cement Stabilized Subgrade
Gravel parking area	300 mm 3-20mm Granular Base Course 300 mm prepared subgrade

- B. The existing main access road from Webber Greens Drive may be retained in so far as it matches Project Co's design access road geometry and elevations.
- C. The existing gravel parking area shall be regraded and refinished with 100 mm of 3-20mm Granular Base Course. The minimum pavement structure for the gravel parking area identified in Table 3-4.3.1 [*Minimum Pavement Structures (Lewis Farms Park and Ride)*] of this Schedule is applicable to the following situations:
 - 1. reinstatement of areas within the Lewis Farms Temporary Parking Facility where excavation has been required;
 - 2. the portions of the access road and pedestrian accesses to the Lewis Farms Temporary Parking Facility within the TUC; and
 - 3. extension of the Lewis Farms Temporary Parking Facility in accordance with Section 3-4.3.1K [*Lewis Farms Park and Ride Requirements*] of this Schedule.

3-4.3.12 Curbs, Gutters, Medians and Sidewalks

- A. All curbs, gutters, medians and sidewalks within the Lewis Farms Site shall comply with the requirements of Section 3-2 [*Roadways, Sidewalks and Shared Use Paths*] of this Schedule.
- B. Curbs and gutters shall be constructed monolithically when attached to a platform or sidewalk.

3-4.3.13 Pavement Marking and Signage

- A. Design and install all permanent pavement markings in accordance with:
 - 1. the *Valley Line West LRT Roadways Design and Construction Standards*; and
 - 2. the *City of Edmonton Design and Construction Standards, Volume 8 – Pavement Markings*.
- B. Delineate all parking stalls within the Lewis Farms Permanent Parking Facility with 10 cm wide yellow lines.
- C. In consultation with ETS, provide all wayfinding and regulatory signs within the Lewis Farms Park and Ride.

Section 3-5 STORMWATER MANAGEMENT

3-5.1 SCOPE

- A. This section sets out the requirements for the Stormwater Management System, including the installation of new and modification or removal of existing Stormwater Management infrastructure required to manage stormwater and other flows within and from the Lands.

3-5.2 REFERENCE STANDARDS

- A. Without limiting Section 1-1.7 [*Reference Documents*] of this Schedule, and except as otherwise specified herein, the Stormwater Management System and all associated Infrastructure shall comply with the following codes, standards and regulations:
1. EPCOR Design and Construction Standards, Volume 3: Drainage (August 2020)
 2. EPCOR Drainage Services Bylaw (City of Edmonton Bylaw 18100);
 3. City of Edmonton Drainage Bylaw (City of Edmonton Bylaw 18093);
 4. City of Edmonton Erosion and Sediment Control Field Manual;
 5. the following clause in Section 6.0 of the Municipal Policies and Procedures Manual, Alberta Environment: "Stormwater management techniques to improve water quality shall be included to effect a minimum of 85% removal of sediments of particle size 75 microns or greater";
 6. City of Edmonton Stormwater Low Impact Development Best Management Practices Design Guide, Edition 1.1;
 7. City of Edmonton Low Impact Development Construction, Inspection & Maintenance Guide, Edition 1.0;
 8. The Standards and Guidelines for Municipal Waterworks, Wastewater and Storm Drainage Systems (Alberta Environment and Parks);
 9. Valley Line West LRT Roadways Design and Construction Standards;
 10. Valley Line West LRT Landscaping Design and Construction Standards;
 11. EPCOR Design Standards Volume 4: Water;
 12. EPCOR Sewer Connection Guidelines; and
 13. Alberta Transportation Design Bulletin 16 (For Design and Construction within the TUC Only).
- B. In the event of any conflict, ambiguity or inconsistency between or among the requirements of the above listed codes, standards and regulations, the requirements shall apply in the order listed in Section 3-3.2.1A [*Reference Standards*] of this Schedule.

3-5.3 DESIGN CRITERIA

3-5.3.1 General

- A. Design and Construct the Stormwater Management System to accommodate the following design storm events: the 1:2 year, 1:5 year, 1:25 year and 1:100 year design events, each as defined in the EPCOR Drainage Design and Construction Standards, Volume 3: Drainage (August 2020).

- B. The Stormwater Management System shall be designed in accordance with the goals and principles set out in the following City of Edmonton documents, copies of which are included in the Disclosed Data:
1. Approval-to-Operate (No. 639-03-03);
 2. Stormwater Quality Control Strategy and Action Plan;
 3. Total Loading Plan;
 4. Combined Sewer Overflow Control Strategy;
 5. Combined Sewer Discharge Strategy;
 6. Downtown Intensification Plan; and
 7. Stormwater Integrated Resources Plan.
- C. Provide Positive Drainage away from all foundations, including the Trackway Underdrain and the Lewis Farms Park and Ride site Wick Drain system.
- D. Provide Minor Drainage systems to carry stormwater runoff for events up to and including the 1:5 year design event.
- E. Provide Major Drainage systems to carry stormwater runoff in excess of the capacity of the Minor Drainage systems, for events up to and including the 1:100 year design event.
- F. Except at the following sites, Design and Construct the Stormwater Management System to meet the City of Edmonton Drainage Design and Construction Standards for rain events up to and including the 1:100 year design event. Design and Construct the Stormwater Management System at the following sites to mitigate maximum ponding depths on top-of-rail such that the existing conditions for events up to an including the 1:100 year design event are not made worse:
1. 87 Avenue at 189 Street;
 2. Meadowlark Road at 90 Avenue;
 3. Stony Plain Road at 151 Street; and
 4. 104 Avenue at 109 Street.
- G. Design and Construct the Stormwater Management System to:
1. meet the Sustainable Urban Integration objectives and requirements of this project;
 2. maximize use of existing infrastructure; and
 3. protect downstream Stormwater Management systems and the Environment.
- H. Design and Construct the Stormwater Management System to provide:
1. runoff quantity control (for all events up to and including the 1:100 year design event);
 2. runoff quality treatment, in accordance with Section 3-5.3.2 [*Water Quality Treatment*] of this Schedule; and
 3. spill containment, in accordance with Section 3-5.3.2 [*Water Quality Treatment*] of this Schedule.

- I. Design and Construct the Stormwater Management System such that drainage from the City Lands does not adversely impact adjacent properties or the surrounding Environment, including properties, Roadways, sidewalks and SUPs.
- J. Design and Construct the Stormwater Management System to not:
 - 1. increase runoff peak flows by more than 10% to the existing EPCOR Water Services Inc. (Drainage) Stormwater Management systems or the Environment;
 - 2. increase surface ponding depths or create additional risk of flooding on adjacent properties;
 - 3. adversely impact runoff quality; or
 - 4. increase the risk of spilled materials discharging to receiving systems.
- K. The Stormwater Management System shall be a gravity system. Pumping of stormwater runoff is prohibited. However, groundwater flows collected in the Lewis Farms Park and Ride site Wick Drain system may be pumped to a local Minor Drainage system if gravity discharge is not achievable.
- L. Provide accessible water quality monitoring points upstream and downstream of all peak flow reduction and water quality treatment facilities (except catch basins). Provide accessible flow monitoring points downstream of all peak flow reduction and water quality treatment facilities (except catch basins).
- M. Provide trash guard systems, including grates over inlets, to intercept trash and other materials that may reduce the conveyance capacity of any existing EPCOR Water Services Inc. (Drainage) Stormwater Management system.
- N. Direct all stormwater discharges from the City Lands to locations that will not impact pedestrians, private properties or result in erosion. Provide erosion control measures at discharge sites susceptible to erosion, including all sites without hard surfaces.
- O. Provide backflow prevention valves on the discharges from the following Stormwater Management System components, when discharging to the existing EPCOR Water Services Inc. (Drainage) Combined Sewer system:
 - 1. Trackway drainage systems;
 - 2. Trackway foundation drainage systems;
 - 3. stormwater storage elements; and
 - 4. stormwater LID measures.

3-5.3.2 Water Quality Treatment

- A. Design and Construct the Stormwater Management System such that its discharges will not contain substances that may be deleterious to the Environment. Discharges from the Stormwater Management System into the existing EPCOR Water Services Inc. (Drainage) Stormwater Management systems shall comply with the water quality requirements set out in the documents referenced in Section 6-4.2 [*Applicable Codes Standards and Regulations*] of this Schedule.
- B. Provide grit management measures to capture and prevent grit from being transferred to the existing EPCOR Water Services Inc. (Drainage) Stormwater Management systems or to the Environment. Grit management measures are to be sized to capture grit from events up to and including the 1:5 year design event. Provide easy access to grit management measures for maintenance by standard maintenance practices.

- C. Design and Construct grit management measures to prevent trapped materials from being flushed through for events up to and including the 1:100 year design event.
- D. Provide runoff water quality treatment measures, in addition to grit management, where runoff quality (other than grit) may be degraded, including at the Lewis Farms Park and Ride.
- E. Provide a multi-barrier approach to stormwater quality treatment to ensure site discharge water quality complies with the water quality requirements of this Section 3-5.3.2 *[Water Quality Treatment] of this Schedule*, including infiltrating LID measures.
- F. Design and Construct water quality treatment measures to provide ease of access for regular monitoring and maintenance activities.
- G. Provide grit management at all stormwater inlets. Grit management measures may be provided at the base of Elevated Guideway decks if it is demonstrated that the slope of the conveyance pipe has capacity to pass grit during common runoff events.
- H. Submit a Spill Containment Strategy which shall:
 - 1. identify, describe, quantify and estimate the likelihood of occurrence of the types of spills that have potential to occur throughout the Project during its Construction and future operations;
 - 2. describe the spill containment capacities of the various proposed Stormwater Management System elements and their capacity to contain collected materials during storm events up to and including the 1:100 year design event; and
 - 3. propose any additional measures that may be required to contain spills at any location throughout the project.

3-5.4 MINOR DRAINAGE

3-5.4.1 General

- A. Design and Construct the Minor Drainage systems to provide seamless connectivity to the existing EPCOR Water Services Inc. (Drainage) Minor Drainage systems.
- B. Direct all stormwater runoff from the City Lands and the designated catchment area(s) to the Minor Drainage system for events up to and including the 1:5 year design event, as follows:
 - 1. runoff is to be directed to the EPCOR Water Services Inc. (Drainage) storm sewer system as a priority; or
 - 2. runoff may be directed to the EPCOR Water Services Inc. (Drainage) combined sewer system where an EPCOR Water Services Inc. (Drainage) storm sewer system is not available.

3-5.4.2 Peak Flow Mitigation

- A. Design and Construct the Minor Drainage systems such that peak runoff discharges from the City Lands to the existing Minor Drainage systems during the 1:5 year design event do not exceed the predevelopment rates by more than 10%.
- B. Design and Construct the Minor Drainage systems such that peak runoff discharges from the City Lands to the existing Minor Drainage systems during the 1:100 year design event do not exceed the 1:100 year predevelopment rates by more than 10%.

3-5.4.3 Peak Flow Reduction Measures

- A. Provide peak flow reduction measures, sized to:
1. limit peak runoff discharges from the City Lands during the 1:5 year design event to the predevelopment rates; and
 2. limit peak runoff discharges from the City Lands during the 1:100 year design event to not more than 110% of the 1:100 design event predevelopment rates.
- B. Where Structural Soil Cells are used as peak flow reduction measures, they shall be designed and constructed to:
1. comply with the *EPCOR Drainage Design and Construction Standards, Volume 3: Drainage (August 2020)*, *City of Edmonton Low Impact Development Best Management Practices Design Guide* and the *City of Edmonton Low Impact Development Construction, Inspection & Maintenance Guide* with LID soils and landscape requirements provided in the *Valley Line West LRT Landscape Design and Construction Standards* taking precedence;
 2. use a soil mix engineered to provide a 0.2 void ratio for water movement, and adequate water retention features to retain water for use by trees and other plantings;
 3. incorporate trees and other plantings as required by Section 2-14 [*Landscape Architecture*] of this Schedule;
 4. incorporate catch basins to collect grit and convey local surface runoff for events up to and including the 1:5 year design event into the Structural Soil Cells, spaced:
 - a. at maximum intervals of 50 m; and
 - b. so as to provide balanced distribution of flows;
 5. provide a means of distributing flows from the catch basins to the engineered soils in a uniform manner, including a perforated distribution piping system located along the top of the soils within the soil cells, and a 150 mm void space between the top of the soils and the top of the soil cells to maximize the distribution of inflows through the soils, as a means of minimizing short-circuiting;
 6. incorporate means of preventing the movement of fine materials into the Minor Drainage system and to provide Positive Drainage through the Structural Soil Cell;
 7. discharge to the Minor Drainage system at maximum intervals of 200 m; and
 8. include distribution and Underdrain systems designed and constructed to accommodate inspection and flushing through the provision of the following features:
 - a. incorporate a means of direct access from the surface; and
 - b. be minimum 200 mm diameter pipe with minimum diameter bends as specified by the applicable pipe manufacturer.
- C. In the event of any conflict, ambiguity or inconsistency between or among the requirements of Section 3-5.4.3B [*Peak Flow Reduction Measures*] of this Schedule, the most stringent requirements shall prevail.
- D. Where Structural Soil Cells are used as peak flow reduction measures, provide separate catch basins that route surface runoff directly to the Minor Drainage systems:

1. for events in excess of the capacity of the Structural Soil Cells up to and including the 1:5 year design event; and
 2. during periods when the soils within the Structural Soil Cells may be frozen.
- E. Utility Infrastructure may be located through or longitudinally within Structural Soil Cells under agreement with the applicable Utility Companies. Structural Soil Cells and any Utility Infrastructure contained within them shall comply with the ULA requirements set out in the ULA Process.

3-5.5 MAJOR DRAINAGE

3-5.5.1 General

- A. Design and Construct the Major Drainage systems to provide seamless connectivity to the existing EPCOR Water Services Inc. (Drainage) Major Drainage systems.
- B. The Major Drainage system shall be:
1. a surface grading configuration that contains all surface runoff during events up to and including the 1:100 year design event within the road right-of-way; and/or
 2. storage facilities, with surface inlets and leads, capable of conveying surface runoff from contributing areas from events up to and including the 1:100 year design event into the storage facilities, and providing Positive Drainage to an existing EPCOR Water Services Inc. (Drainage) Stormwater Management system at rates controlled to the capacity limitations of the downstream systems.
 3. Ponding depth on roadways and other public rights of way shall be less than 350mm and below any openings at any adjacent buildings.
- C. The Major Drainage system shall include measures to prevent erosion or undermining of the Infrastructure.

3-5.5.2 Flood Mitigation of Trackway

- A. Design and construct the Major Drainage system along the Trackway such that:
1. ponding and overland flow within the Trackway does not exceed the top of rail for any type of Track, other than Embedded Track, during events up to and including the 1:100 year design event;
 2. ponding and overland flow within the Trackway does not exceed the top of rail for Embedded Track during events up to and including the 1:5 year design event;
 3. maximum ponding depths on the top of rail at the following locations are minimized for all events up to the 1:100 year event to minimize impacts on future operations:
 - a. 87 Avenue at 189 Street,
 - b. Meadowlark Road at 90 Avenue,
 - c. Stony Plain Road at 151 Street, and
 - d. 104 Avenue at 109 Street;
 4. ponding and overland flow within the Trackway of Embedded Track for all locations along the LRT Corridor, other than those identified in Section 3-5.5.2A.3 [*Flood Mitigation of Trackway*] of this

Schedule, during design events up to and including the 1:100 year design event, does not exceed the lesser of:

- a. 75 mm, or
 - b. the maximum depth of water through which the LRV can pass without damage; and
5. ponding and overland flow does not occur at any point of safety or emergency egress pathway (each as described in NFPA 130) along Elevated Guideways for events up to and including the 1:100 year design event.
- B. Design and construct staff gauges at the four ponding risk locations identified in Section 3-5.5.2A.3 [*Flood Mitigation of Trackway*] of this Schedule to provide Drivers information of depths of ponding on top of rail at these locations to allow Drivers to safely approach, bring the Train to a stop without entering the flood zone and determine when it is safe to proceed. Staff gauges are to be constructed to the following criteria:
1. The staff gauges shall be located:
 - a. such that they measure ponding water levels that occur on top of rail at the lowest point along the rail in both directions at the intersection;
 - b. such that two gauges are provided in each direction approaching the sag intersections such that both are visible to oncoming LRVs from both directions before the LRVs reach the intersections as follows:
 - i. immediately ahead of the intersection sag; and
 - ii. 50 m before the intersection sag;
 - c. between east and west bound rails or north and south bound rails; and
 - d. on OCS poles or on separate, independent posts and coordinated with the Valley Line LRT Stage 2 Sightline Study;
 2. Each staff gauge shall be marked as follows:
 - a. have a clear title at the top of the gauges that reads: "Water Ponding Levels on Top of Rail (mm)";
 - b. have "Top of Rail" labeled and a solid line clearly indicating top of rail;
 - c. have water level markings at 25 mm increments above top of rail for a total depth of 1,000 mm; and
 - d. include labels every 100 mm indicating total depth on top of rail;
 3. Each staff gauge shall be designed and constructed:
 - a. of reflective materials to aid in the ability of the Drivers to see them in difficult lighting conditions;
 - b. using colours, font types and sizes easily readable from a distance;
 - c. using finishes not susceptible to fading; and
 - d. with a Design Service Life of 30 years.

- C. Design and construct warning signs ahead of the four ponding risk locations identified in Section 3-5.5.2A.3 [*Flood Mitigation of Trackway*] of this Schedule to warn Drivers that the upcoming intersection is susceptible to ponding during heavy rain events, and that they are to look for upcoming staff gauges for ponding water level information. Warning signs are to be constructed to the following criteria:
1. The warning signs shall be located:
 - a. 100m ahead of the sag intersections in both directions approaching the sag intersections;
 - b. between east and west bound rails or north and south bound rails; and
 - c. on OCS poles or on separate, independent posts and coordinated with the Valley Line LRT Stage 2 Sightline Study.
 2. Each warning sign shall be marked with a clear label that reads: "WARNING Water May Pond on Top of Rail During Heavy Rains";
 3. Each warning sign shall be designed and constructed as follows:
 - a. of reflective materials to aid in the ability of the Drivers to see them in difficult lighting conditions;
 - b. using colours, font types and sizes easily readable from a distance;
 - c. using finishes not susceptible to fading; and
 - d. with a Design Service Life of 30 years.

3-5.5.3 Overland Flow Control

- A. Design and Construct the Stormwater Management System such that peak runoff discharges and discharge volumes from the City Lands to the Environment during events up to and including the 1:100 year design event do not exceed the predevelopment rates or volumes by more than 10%.
- B. Design and Construct the Stormwater Management System to not alter or disrupt existing overland flow patterns from areas external to the City Lands that flow onto, across and off of the City Lands that will consist of Embedded Track or Direct Fixation Track sections, unless otherwise specified herein or required to comply with Section 3-5.5.2 [*Flood Mitigation of Trackway*] of this Schedule. Wherever existing overland flow patterns from areas external to the City Lands are altered or disrupted, such flow volumes shall be controlled by the Stormwater Management System for events up to and including the 1:100 year design event.
- C. Existing overland flow patterns from areas external to the City Lands that flow across the City Lands that will contain Ballasted Track sections shall be prevented from entering the Ballasted Track sections by being intercepted, controlled and redirected away from the Ballasted Track sections by the Stormwater Management System for events up to and including the 1:100 year design event.
- D. Peak runoff discharges from the City Lands for events greater than the 1:5 year design event can overflow the Minor Drainage system and run off the City Lands onto the adjacent existing Major Drainage systems or to natural Environments with adequate erosion control, subject to Section 3-5.5.4 [*Flood Mitigation of Properties*] of this Schedule.

3-5.5.4 Flood Mitigation of Properties

- A. Surface grading along the following at-risk reaches of the City Lands shall be designed to contain all runoff from events up to and including the 1:100 year design event within the public right-of-way to prevent flooding into adjacent building openings on:
 - 1. 102 Avenue;
 - 2. 107 Street; and
 - 3. Stony Plain Road between 149 Street to 156 Street.
- B. With the exception of the most at-risk reaches of the LRT Corridor identified in Section 3-5.5.4A [*Flood Mitigation of Properties*] of this Schedule, Design and Construct the Stormwater Management System so there is no increase in ponding within the City Lands that may extend onto adjacent properties during the 1:100 year design event.

3-5.6 STORMWATER MANAGEMENT – SPECIFIC FACILITIES

3-5.6.1 Track Drainage

- A. The Stormwater Management System shall include such Minor Drainage and Major Drainage systems as required to comply with the flood mitigation requirements of Section 3-5.5.2 [*Flood Mitigation of Trackway*] of this Schedule.
- B. Provide Trackway drain inlets upstream of all crosswalks to prevent ponding or overland flows across crosswalks for events up to and including the 1:5 year design event.
- C. Provide Minor Drainage systems for all Ballasted Track sections of the Trackway sized to convey runoff from within the Trackway for events up to and including the 1:25 year design event. Discharges from the Minor Drainage systems for Ballasted Track sections to the City's existing Minor Drainage systems shall comply with the requirements of Section 3-5.4.2 [*Peak Flow Mitigation*] of this Schedule.
- D. Design and Construct Direct Fixation Track to be raised on direct fixation supports with at least 50 mm of clearance above the Track Slab. Openings below the track and between the direct fixation support shall be at a minimum 50 mm in height and a minimum of 300 mm in length, spaced at a maximum of 2500 mm intervals along the Track alignment in order to provide ample capacity to pass runoff expected from events up to and including the 1:100 year design event between the Track and slab, with a minimum risk of blockage.
- E. The minimum inside pipe diameter for track drainage inlets shall be 250mm and have a minimum grade of 1.0%.

3-5.6.2 Lewis Farms Site

- A. Design and Construct the Stormwater Management System within the Lewis Farms Site such that all stormwater runoff from the site is isolated from all sources of stormwater runoff outside of the Lewis Farms Site, other than the adjacent existing Lewis Farms Transit Centre, for events up to and including the 1:100 year design event.
- B. Design and Construct the Lewis Farms Site Minor Drainage system to service the existing adjacent Lewis Farms Transit Centre Minor Drainage system by gravity and abandon the existing lift station.
- C. Runoff from the parking areas of the Lewis Farms Site shall be routed through linear bioretention basins (LID Bioswales) which shall be located within the parking areas. Areas draining to linear bioretention basins (LID Bioswales) should be maximized as practicably as possible. Runoff from low points and

sags may be permitted to drain to catch basins that directly connect to the Minor Drainage system. Runoff from events up to and including the 1:5 year design event shall be routed through a Minor Drainage system that discharges south into the existing Potter Greens East Stormwater Management Facility (SWMF) from the following systems:

1. underdrain and overflow discharges from the linear bioretention basins (LID Bioswales); and
 2. runoff from the remaining portions of the Lewis Farms Site, including building rooftop drainage.
- D. Design and Construct the Lewis Farms Site Minor Drainage System to discharge by gravity as follows:
1. the invert of the downstream pipe at the last manhole before the SWMF shall be at or above the NWL of the SWMF of 685.0m; and
 2. the top of the pipe from the last downstream manhole to the SWMF shall be located at least 1.0m below NWL as it discharges into the SWMF to prevent freezing in winter.
- E. Design and Construct the Lewis Farms Site Major Drainage system:
1. to route flow south, overland to the existing Potter Greens East SWMF, for events up to and including the 1:100 year design event;
 2. such that the maximum depth of any overland flow or ponding within the Lewis Farms Site does not exceed 300 mm for any event up to and including the 1:100 year design event; and
 3. such that surface ponding does not occur on pedestrian or driving areas within the Lewis Farms Site for events up to and including the 1:5 year design event.
- F. Provide a multi-barrier approach to stormwater quality treatment and stormwater LID measures employing natural treatment processes to ensure site discharge water complies with the water quality treatment requirements of Section 3-5.3.2 [*Water Quality Treatment*] of this Schedule.
- G. Where stormwater linear bioretention basins (LID Bioswales) are used to manage stormwater runoff from the Lewis Farms Site, the linear bioretention basins (LID Bioswales) shall be designed and constructed to comply with the *EPCOR Drainage Design and Construction Standards, Volume 3: Drainage (August 2020)*
- H. Design and Construct a Wick Drain system below the Subgrade of the Lewis Farms Site to keep groundwater levels below the Subgrade to prevent heaving, and route collected flows by gravity to a piped Underdrain system.
- I. Design and Construct a piped Underdrain system:
1. to collect flows from the Wick Drain system and route them by gravity to the on-site Minor Drainage System; and either
 2. located in its entirety above the HWL of the Potter Greens East SWMF of 688.4 m if it is connected to the Minor Drainage System by gravity, in order to ensure Positive Drainage is maintained during high water conditions in the downstream SWMF; or
 3. that discharges collected flows by pumping vertically into the Minor Drainage System, should site design constraints prevent gravity servicing from being feasible.
- J. Design and Construct the Lewis Farms Storage Facility Building such that it is located entirely outside of the HWL of the Potter Greens East SWMF.

3-5.6.3 West Edmonton Mall Site

- A. Design and Construct the Stormwater Management System within the West Edmonton Mall Site to include a Minor Drainage and Major Drainage system that directs site runoff, for all events up to and including the 1:100 year event, to the existing EPCOR Water Services Inc. (Drainage) Minor Drainage and Major Drainage systems on 87 Avenue.
- B. Design and Construct the rooftop drainage systems of Building Structures within the West Edmonton Mall Site in accordance with Section 3-5.6.5 [*Building Structures*] of this Schedule.

3-5.6.4 Gerry Wright OMF Stage 2

- A. Design and Construct the Stormwater Management Systems within the Gerry Wright OMF Parcel B to drain stormwater runoff from the Gerry Wright OMF Parcel B for events up to and including the 1:100 year design event, to discharge east into the new Stormwater Management Facility (SWMF) in Gerry Wright OMF Parcel C that will be provided by Other Contractor for Valley Line LRT Stage 1 to service all parcels of the Gerry Wright OMF Site.
- B. Confirm that the orifice within the existing Gerry Wright Stormwater Management Facility outlet control structure is sized to pass a maximum rate of 35 L/s/ha over the entire upstream contributing area during pond high water conditions, and if required, resize the orifice to achieve this requirement.
- C. Design and Construct the Stormwater Management Systems within the Gerry Wright OMF Parcel B to provide a multi-barrier approach to stormwater quality treatment and stormwater LID measures employing natural treatment processes to ensure site discharge water complies with the water quality treatment requirements of Section 3-5.3.2 [*Water Quality Treatment*] of this Schedule.
- D. Design and Construct the conveyance system from the Gerry Wright OMF Parcel A to route through the Gerry Wright OMF Parcel B to the SWMF within the Gerry Wright OMF Parcel C in accordance with the requirements related to Pipeline Crossings in Schedule 5, Part 8-2 [*Maintenance and Storage Facilities, Gerry Wright OMF*].
- E. The Gerry Wright OMF Parcel B shall be developed in a manner that maintains conveyance capacity for runoff from the Gerry Wright OMF Parcel A to route through the Gerry Wright OMF Parcel B to the SWMF within the Gerry Wright OMF Parcel C during the 1:100 year design event as it currently does.
- F. Construct any components of the Stormwater Management within Gerry Wright OMF Parcel C required for the Gerry Wright OMF Parcel B. Connections for Stormwater Management from Gerry Wright OMF Parcel A may be constructed through Gerry Wright OMF Parcel B subject to compliance with Schedule 28 [*Project Approvals and Utility Matters*].
- G. Connect the Stormwater Management System required for the Gerry Wright OMF Parcel B with the Gerry Wright OMF Parcel A constructed as part of the Valley Line LRT Stage 1 in accordance with Section 1-1.4 [*Integration with Valley Line LRT Stage 1*] of this Schedule.

3-5.6.5 Building Structures

- A. Design and Construct Building Structure rooftops to direct runoff from all events up to and including the 1:5 year design event into gutters and drained through downspouts.
- B. Design and Construct Building Structure rooftop downspouts to discharge:
 - 1. onto adjacent absorptive landscaped areas for all events up to and including the 1:2 year design event, with energy dissipation provided to prevent erosion of the landscaped areas, and with excess runoff above the 1:2 year runoff to bypass the absorptive landscaped areas;

2. directly into the local Minor Drainage systems where absorptive landscaped areas are not available, and where the Minor Drainage system is located in the vicinity of the downspout; or
 3. onto surface areas not designated for regular pedestrian use (e.g. Roadway gutters), where absorptive landscaped areas or Minor Drainage systems are not available, and in a manner that does not negatively impact the public, private property or cause erosion.
- C. Where downspouts discharge directly onto surface areas susceptible to erosion (non-hard surface areas), provide energy dissipation measures sufficient to prevent erosion.
- D. Design and construct rooftop drainage systems in a manner that controls melting snow or ice from falling onto pedestrians.

3-5.6.6 Elevated Guideways

- A. Design and Construct the decks of Elevated Guideways such that:
1. stormwater runoff, for events up to and including the 1:100 year design event, is conveyed in gutters and swales along the decks and routed to inlets spaced at intervals no greater than 120 m, with inlet flows directed to ground level through downspouts at support piers; and
 2. stormwater runoff, for events up to and including the 1:100 year design event, does not spill over the sides of the decks and does not impact future operations. In addition to inlets/downspouts, deck runoff up to the 1:100 year design event may be routed along the surface of the deck to the adjacent Roadway Minor Drainage and Major Drainage systems.
- B. Design and Construct Elevated Guideway deck downspouts to discharge:
1. in accordance with the SU1 requirements as noted in Section 2-9 [*Support Systems*] of this Schedule;
 2. onto adjacent absorptive landscaped areas for all events up to and including the 1:2 year design event, with energy dissipation provided to prevent erosion of the landscaped areas, and with excess runoff above the 1:2 year runoff to bypass the absorptive landscaped areas;
 3. into the local Minor Drainage systems where absorptive landscaped areas are not available, and where the Minor Drainage system is located in the vicinity of the downspout; or
 4. onto surface areas not designated for regular pedestrian use or vehicular traffic (e.g. Roadway gutters), where absorptive landscaped areas or Minor Drainage systems are not available, and in a manner that does not impact the public, vehicular traffic, private property or cause erosion.
- C. Provide energy dissipation measures sufficient to prevent erosion wherever downspouts discharge directly onto surface areas susceptible to erosion (non-hard surface areas).
- D. Provide grit management through grit traps located at either of the following locations:
1. on the deck immediately below the inlets; or
 2. at the ground level outlets of the downspouts provided the downspouts are designed with sufficient slope to ensure conveyance of grit to ground level.
- E. Design and Construct grit traps to:
1. contain grit from events up to and including the 1:5 year design event; and

- 2. prevent captured grit from being flushed out during events up to and including the 1:100 year design event.
- F. Refer to Schedule 5, Part 2 [*Sustainable Urban Integration*] for requirements of passive irrigation systems in the Under Guideway Landscape Areas.
- G. Design and Construct swale systems down the embankments of the Anthony Henday Drive LRT Bridge and Stony Plain Road Bridge to convey Major Drainage runoff onto the roadways below, in a manner that dissipates energy and prevents erosion, if that is the route of the Major Drainage flows.

3-5.6.7 87 Avenue Elevated Guideway Piles Close to Sewer Lines

- A. Refer to Part 4, Section 4-3.1.3 [*87 Avenue Elevated Guideway Piles Close to Sewer Lines*] of this Schedule for requirements for piling in close proximity of sewer lines along the 87 Avenue Elevated Guideway.

3-5.7 SEWER RELOCATIONS

The sewer relocation criteria below is relevant to all sewer types including storm sewer, sanitary sewer and combined sewer infrastructure.

3-5.7.1 Relocation Criteria

- A. Relocate all existing sewer infrastructure and appurtenances (including manholes and catch basins), that may impede the Construction of the LRT.
- B. Without limiting Section 3-5.7.1A [*Relocation Criteria*] of this Schedule, relocate the following sewer infrastructure and appurtenances:
 - 1. existing sewer infrastructure located below proposed catenary poles, with less than 10m cover (depth from existing ground to top of pipe), shall be relocated to outside the LRT Zone of Influence;
 - 2. existing sewer infrastructure, other than those identified in Section 3-5.7.1B.1 [*Relocation Criteria*] of this Schedule, running parallel within plan footprint of the LRT Zone of Influence with less than 7 m cover (depth from existing ground to top of pipe), shall be relocated to outside of the LRT Zone of Influence;
 - 3. existing sewer pipe infrastructure (e.g. sewer mains, catch basin leads, and services) being extended to new sewer infrastructure crossing the LRT Zone of Influence with less than 7 m cover shall be removed and replaced with new sewer pipe. Sewer services shall be replaced from the sewer main to property line. The new sewer pipe shall be installed in a casing extending a minimum 2.0 m beyond the LRT Zone of Influence;
 - a. The following sewer mains require removal and replacement with new sewer pipe and casing crossing the LRT Zone of Influence:

Table 3-5.7.1 Sewer Main Removal and Replacement with Casing Locations

Facility ID	Roadway	Cross Street	Sewer Type	Pipe Diameter (mm)
306155	87 Avenue	W of 189 Street	Storm	250
41505	87 Avenue	189 Street	Storm	675
41526	87 Avenue	E of 189 Street	Storm	300
434465	87 Avenue	159 Street	Sanitary	250

Facility ID	Roadway	Cross Street	Sewer Type	Pipe Diameter (mm)
62182	Meadowlark Rd	88B Avenue	Storm	300
63516/312366	156 Street	97 Avenue	Storm	375
63589/311047	156 Street	98 Avenue	Storm	375
63586/311102/311106	156 Street	99 Avenue	Storm	375
63595/311133/311134	156 Street	100 Avenue	Storm	375
49927	Stony Plain Rd	146 Street	Combined	250
49881	Stony Plain Rd	144 Street	Storm	450
30286	103 Avenue	107 Street	Storm	450

- b. The following sewer services require removal and replacement with new sewer pipe and casing crossing the LRT Zone of Influence:

Table 3-5.7.2 Sewer Services Removal and Replacement with Casing Locations

WASS Service ID	Roadway	Cross Street	Sewer Type	Pipe Diameter (mm)
R-49363	87 Avenue	W of 182 Street	Storm	200
R-49362	87 Avenue	W of 182 Street	Storm	150
N-52954	156 Street	N of 93A Avenue	Sanitary	100
N-52956	156 Street	N of 93A Avenue	Sanitary	100
N-52958	156 Street	N of 93A Avenue	Sanitary	100
N-102137	156 Street	N of 93A Avenue	Sanitary	150
R-75932	156 Street	N of 93A Avenue	Sanitary	150
N-52967	156 Street	N of 95 Avenue	Sanitary	100
R-54543	156 Street	N of 95 Avenue	Storm	250
R-52969	156 Street	N of 95 Avenue	Storm	200
N-52972	156 Street	N of 95 Avenue	Sanitary	100
R-58090	156 Street	N of 98 Avenue	Storm	150
N-53030	156 Street	N of 98 Avenue	Sanitary	150
N-53032	156 Street	N of 99 Avenue	Sanitary	100
N-53034	156 Street	N of 99 Avenue	Sanitary	100
N-53036	156 Street	N of 99 Avenue	Sanitary	100
N-53040	156 Street	N of 99 Avenue	Sanitary	100
N-53043	156 Street	N of 99 Avenue	Sanitary	100
N-53045	156 Street	N of 99 Avenue	Sanitary	100
N-53048	156 Street	N of 99 Avenue	Sanitary	100
N-53050	156 Street	N of 99 Avenue	Sanitary	100
N-53052	156 Street	N of 99 Avenue	Sanitary	100
R-104772	Stony Plain Rd	E of 142 Street	Storm	250
N-21702	107 Street	S of 104 Avenue	Sanitary	150
N-16301	107 Street	S of 104 Avenue	Sanitary	150
N-10417	107 Street	S of 104 Avenue	Sanitary	150
R-86696	107 Street	S of 104 Avenue	Storm	200
N-19014	107 Street	S of 104 Avenue	Sanitary	150
N-2985	107 Street	S of 104 Avenue	Sanitary	150
R-77761	107 Street	S of 104 Avenue	Storm	150
N-4365	107 Street	S of 104 Avenue	Sanitary	100
N-18881	107 Street	S of 104 Avenue	Sanitary	150

WASS Service ID	Roadway	Cross Street	Sewer Type	Pipe Diameter (mm)
N-146571	107 Street	S of 103 Avenue	Sanitary	200
R-80369	102 Avenue	W of 106 Street	Storm	200
R-51746	102 Avenue	L/W of 106 Street	Storm	200

4. existing sewer infrastructure located below proposed Elevated Guideway piers, or within a 1.5m horizontal clearance from the piles required to support the piers, shall be relocated to outside the LRT Zone of Influence to avoid conflict with the piles;
5. existing surface sewer infrastructure (e.g. manholes, catch basins, catch basin manholes, etc.) located within the LRT Zone of Influence shall be relocated outside the LRT Zone of Influence; and
6. existing sewer infrastructure crossing the LRT Zone of Influence or under any other Structure with less than 2.0 m cover from the top of pipe to the bottom of the Trackway or Structure shall be relocated so as to provide a minimum of 2.0 m cover.

3-5.7.2 Abandonment

- A. Portions of any existing sewer infrastructure that are abandoned or to be abandoned shall be removed if the abandoned sewer infrastructure would be within 2.0 m from top of rail of the LRT infrastructure.
- B. All other portions of existing sewer infrastructure that are relocated shall be abandoned in-situ by confirming that the infrastructure has been disconnected from operating infrastructure and abandoned in accordance with *Section 02535 3.13 Abandonment of Sewers of the EPCOR Drainage Design and Construction Standards, Volume 3: Drainage (August 2020)*.
- C. Portions of the existing sewer infrastructure that are to be abandoned along Stony Plain Road from 124 Street to 121 Street and on 104 Avenue from 120 Street to 109 Street shall be completed per the Sewer Abandonment package prepared by EPCOR Water Services Inc. (Drainage). Sewer abandonments are to be completed following disconnection of catch basins to the combined sewer and reconnection of catch basins to the newly relocated combined sewer by EPCOR Water Services Inc. (Drainage) as provided in the disclosed data.

3-5.7.3 Relocation Standards

- A. All sewer infrastructure that is relocated shall be replaced with equivalent sizes/carrying capacities as the infrastructure that is replaced, and with equivalent type of sewer (e.g. combined with combined, etc.).
- B. Notwithstanding Section 3-5.7.3A [*Relocation Standards*] of this Schedule, all sewer infrastructure that is relocated shall be replaced with the following minimum pipe sizes:
 1. locations where an existing sanitary sewer is to be relocated, a minimum pipe diameter of 250 mm is required for the relocated pipe regardless of the downstream sewer diameter; and
 2. locations where an existing storm sewer or combined sewer is to be relocated, a minimum pipe diameter of 300 mm is required for the relocated pipe regardless of the downstream sewer diameter.

- C. All new sewer infrastructure shall comply with *EPCOR Drainage Design and Construction Standards, Volume 3: Drainage (August 2020)*., and the separation requirements identified in this Section 3-5.7 [*Sewer Relocations*] of this Schedule.
- D. For all relocated sewers:
1. new Sewer Service Connections shall be provided to all adjacent properties to be serviced by the new sewer for the entire length of the service connections located within the right of way (from the new sewer to the property line), with the portion of the Sewer Service Connection located within the LRT Zone of Influence to be cased;
 2. Sewer Service Connections to be relocated shall be replaced with the equivalent type of service (e.g. sanitary sewer services replaced with sanitary sewer services, storm services replaced with storm services); and
 3. Where Sewer Service Connections are being relocated, adjusted or replaced, servicing records are to be updated using the WASS data entry forms. Project Co shall coordinate with wass.applications@epcor.com to obtain a WASS application for any impacted service connections
- E. Relocated sewer infrastructure shall be located such that City and applicable Utility Company's standard clearance criteria with other infrastructure is achieved, and that relocations are coordinated with relocations of other Utility Infrastructure.
- F. All new sewer infrastructure, sewer main, catch basin leads and services, crossing below the Track with less than 7 m cover (depth from existing ground to top of pipe), shall be cased, in accordance with the *EPCOR Drainage Design and Construction Standards, Volume 3: Drainage (August 2020)*.. Casing requirements include:
1. solid wall PVC SDR 35 shall be used for carrier pipe and encasement pipe; profile PVC pipe is not allowed;
 2. casing pipe shall extend a minimum 2.0 m beyond the LRT Zone of Influence;
 3. cover ends of casing with waterproof end seal; and
 4. minimum casing size shall be as specified in Table 3-5.7.3 [*Minimum Casing Pipe Sizing*].

Table 3-5.7.3 Minimum Casing Pipe Sizing

Carrier Pipe Nominal Inside Diameter (mm)	Encasement Pipe Minimum Nominal Diameter (mm)
150	300
200	375
250	450
300	525
375	600
450	675
525	750
600	900
675	900
750	1050

- G. Where catch basins are relocated, they shall be relocated to an adjacent Roadway in accordance with the *EPCOR Drainage Design and Construction Standards, Volume 3: Drainage (August 2020)*.,

and the Roadways shall be graded to provide Positive Drainage of the Roadway drainage system and all other areas contributing to the catch basins.

- H. At locations where a new storm or combined sewer has recently been relocated by EPCOR Water Services Inc. (Drainage) to avoid the LRT, with upstream sewers and sewer services reconnected to the new sewer but with catch basins remaining connected to the original sewer, Project Co shall:
 - 1. connect all catch basins to manholes on the recently relocated storm or combined sewer;
 - 2. ensure no other sources of flow can contribute to the original storm or combined sewer; and
 - 3. abandon the original storm or combined sewer.
- I. There are two access manholes to the deep 1275 mm combined sewer along 102 Avenue located within the LRT Zone of Influence. These locations include:
 - 1. MH 262346 located on 102 Avenue near the lane east of 104 Street; and
 - 2. MH 262411 located on 102 Avenue in the intersection of 103 Street.

Project Co shall remove the top 2 m of the manholes and design a slab/cover to distribute LRT loading off of the remaining manhole structure. For MH 262411, Project Co shall remove and replace the full length of 200 mm combined sewer pipe (pipe ID 30413) with a 250 mm PVC pipe to the upstream manhole.

3-5.7.4 Sewer Services

A. LRT Stops

- 1. Storm and sanitary service connection to LRT stops shall meet the requirements for service connections in the *EPCOR Drainage Design and Construction Standards, Volume 3: Drainage (August 2020)*.
- 2. Where Sewer Service Connections are being installed, relocated, adjusted or replaced, servicing records are to be updated using the WASS data entry forms. Project Co shall coordinate with wass.applications@epcor.com to obtain a WASS application for any impacted service connections

B. Utility Complexes / Traction Power Sub Stations

- 1. Storm and sanitary service connection to Utility Complexes and Traction Power Substations shall meet the requirements for service connections in the *EPCOR Drainage Design and Construction Standards, Volume 3: Drainage (August 2020)*.
- 2. Some Utility Complexes and Traction Power Substation are located on lands with existing storm and sanitary sewer services. Existing sewer services that Project Co plan to utilize for LRT Infrastructure will require service inspection and assessment of condition by EPCOR Water Services Inc. (Drainage). Services are subject to upgrading to current standards by Project Co.
- 3. If the existing service is deemed unsuitable or not to be re-used, Project Co shall be responsible for the design and construction of the service connections and shall meet the requirements for service connections in the *EPCOR Drainage Design and Construction Standards, Volume 3: Drainage (August 2020)*. If existing sewers service will not be re-used:
 - a. sewer services shall be abandoned by Project Co from the sewer main or manhole within Road ROW leading to the titled property or as agreed to with Infill Water and Sewer Servicing (IWASS); and

- b. sewer service abandonments shall be requested by Project Co in writing through iWASS. Project Co shall be responsible for plugging the sewer services to prevent infiltration and sedimentation from entering the EPCOR sewer system with plug locations to be determined by IWASS;
 4. For all Utility Complexes, Project Co shall develop and submit site mechanical and grading plans within property lines for review and approval by iWASS.
 5. Where Sewer Service Connections are being installed, relocated, adjusted or replaced, servicing records shall be updated using the WASS data entry forms. Project Co shall coordinate with wass.applications@epcor.com to obtain a WASS application for any impacted service connections.
- C. Services to Titled Lots that are converted to Road Right of Way (not to be used for LRT Infrastructure)
1. For sewer services to a separately titled lot, which will become Road Right of Way that does not require sewer services:
 - a. sewer services shall be abandoned by Project Co from the sewer main or manhole within Road ROW leading to the titled property or as agreed to with Infill Water and Sewer Servicing (IWASS); and
 - b. sewer service abandonments shall be requested by Project Co in writing through IWASS. Project Co shall be responsible for plugging the sewer services to prevent infiltration and sedimentation from entering the EPCOR sewer system with plug locations to be determined by IWASS.
 2. Where Sewer Service Connections are being relocated, adjusted or replaced, servicing records shall be updated using the WASS data entry forms. Project Co shall coordinate with wass.applications@epcor.com to obtain a WASS application for any impacted service connections.
- D. Services to Titled Lots that shall Remain Titled Lots (where services exist in acquired land)
1. The existing sewer service shall be inspected to confirm the pipe within the acquired land meets current City of Edmonton standards. The pipe may be inspected by televising from the sewer main or by means of daylighting.
 2. If during the inspection the pipe is found to be damaged or otherwise does not meet current standards, the segment of service pipe shall be reconstructed to current standards (and reconnected to existing service pipe with the required fittings.

Any alterations to sewers shall be designed, coordinated and constructed by Project Co once written landowner approval for work on private property has been received.
 3. Commercial and multi-family sites require sampling manholes at property line where a connection is made to the public sewer service. Sampling manholes (and appurtenances) on private property currently located within titled property that become part of Road ROW shall be relocated into private property by Project Co. Project Co shall be responsible for obtaining and verifying site plans from the property owner. If there is no perceived room for a sampling manhole on private property, IWASS will review alternatives proposed by Project Co on a case by case basis. Project Co shall develop and submit site and grading plans to IWASS for review and approval.

Where onsite storm water management is impacted by land acquisitions (for example where the ponding storage capacity is reduced) Project Co shall review with IWASS on a case by case basis to establish infrastructure changes.

Any alterations to sewers shall be designed, coordinated and constructed by Project Co once written landowner approval for work on private property has been received.

4. Table 3-5.7.4 [Sewer Services in Partially Acquired Lands – Single Family and Duplex] provides a summary of properties with single family and duplex houses where a segment of the sewer services (storm or sanitary) is impacted by recent property acquisition caused by the VLW LRT Project.

Table 3-5.7.4 Sewer Services in Partially Acquired Lands – Single Family and Duplex

Property ID	WASS Service ID	Municipal Address	Length of Service Pipe Impacted (m)	Sewer Type
W29	N-138761	9412 156 Street NW	3.1	Sanitary
W29A	N-52952	9416 156 Street NW	3.1	Sanitary
W30	N-52953	9416 156 Street NW	3.1	Sanitary
W31	N-52955	9422 156 Street NW	3.1	Sanitary
W32	N-52957	9426 156 Street NW	3.1	Sanitary
W37	N-52956	9425 156 Street NW	3.6	Sanitary
W38	N-52958	9429 156 Street NW	3.6	Sanitary
W266	N-104702	9401 156 Street NW	2.4	Sanitary
W267	N-52948	9403 156 Street NW	2.4	Sanitary
W268	N-99805	9405 156 Street NW	2.4	Sanitary
W269	N-52950	9407 156 Street NW	2.4	Sanitary
W270	N-101799	9411 156 Street NW	2.4	Sanitary
W271	N-52951	9413 156 Street NW	2.4	Sanitary
W272	N-52954	9421 156 Street NW	3.6	Sanitary
W277	N-53028	9843 156 Street NW	3.1	Sanitary
W286	N-53050	9937 156 Street NW	6.0	Sanitary
W287	N-53052	9941 156 Street NW	6.0	Sanitary
W149	N-3256	12602 Stony Plain Rd NW	4.4	Sanitary

5. Table 3-5.7.5 [Sewer Services in Partially Acquired Lands – Commercial and Multi-Family] provides a summary of commercial and multi-family properties where services (storm or sanitary) are impacted by recent property acquisition caused by the Project.

Table 3-5.7.5 Sewer Services in partially acquired lands- Commercial and Multi-Family

Property ID	WASS Service ID	Municipal Address	Sewer Type	Property Type
W1	N-59115	8402 169 Street NW	Sanitary	Townhome
W1	N-59114	8402 169 Street NW	Sanitary	Townhome
W2	N-59111	8409 169 Street NW	Sanitary	Townhome
W8	R-85371		Storm	Commercial
	R-58046		Storm	
	N-81306		Sanitary	
W190	N-49718	15710 87 Avenue NW	Sanitary	Commercial
	R (unrecorded storm service)		Storm	
	N-98641		Sanitary	
W39/W40/W41	N-102137	9455 156 Street NW	Sanitary	Condominium

Property ID	WASS Service ID	Municipal Address	Sewer Type	Property Type
	R-75932		Storm	
W43	N-79709	9535 156 Street NW	Sanitary	Condominium
	R-54543		Storm	
	R-40697		Storm	
W273	N-52981	9607 156 Street NW	Sanitary	Condominium
W45	N-92995	9707 156 Street NW	Sanitary	Multi-Family
W274	N-53021	9717 156 Street NW	Sanitary	Multi-Family
W276	N-53027	9843 156 Street NW	Sanitary	Condominium
W284	N-53040	9913 156 Street NW	Sanitary	Condominium
W285	N-53045	9935 156 Street NW	Sanitary	Multi-Family
	R-61841		Storm	
W49		10035 156 Street	Sanitary	Commercial
W48	N-57827	15603 100A Avenue	Sanitary	Commercial
W258	N-62518	10050 156 Street NW	Sanitary	Commercial
W93	R16832	10127 145 Street NW	Storm	Church
W151	N-24233	12527 Stony Plain Rd	Sanitary	Commercial
W156	N-5961	10426 124 Street NW	Sanitary	Commercial
W157	N-17975	10429 124 Street	Sanitary	Commercial
	N-36341		Sanitary	
W159	N-22435	10349 122 Street	Sanitary	Empty
W163B	N-18351	11604 104 Avenue NW	Sanitary	Commercial
	N-63164		Sanitary	
	N-63165		Sanitary	
	N-65214		Sanitary	
	N-103488		Sanitary	
	N-103489		Sanitary	
	N-70026		Sanitary	
W163C	N-98705	11410 104 Avenue NW	Sanitary	Commercial
	N-26723		Sanitary	
	N-98706		Sanitary	
W163D	N-109801	11204 104 Avenue NW	Sanitary	Commercial
W167	N-68846	10326 118 Street	Sanitary	Commercial
W185	N-24188	10217 107 Street NW	Sanitary	Commercial
	R-75055		Storm	
W186	R-51746	10536 102 Avenue NW	Storm	Commercial

6. Any alterations shall be designed, coordinated and constructed by Project Co once written landowner approval for work on private property has been received. Proposed Project Co service alterations shall be applied for by Project Co in writing for review and approval by IWASS (wass.drainage@epcor.com).

3-5.8 NEW SEWER INFRASTRUCTURE

3-5.8.1 General

- A. All new sewer infrastructure shall comply with the *EPCOR Drainage Design and Construction Standards, Volume 3: Drainage (August 2020)*.
- B. New sewer infrastructure shall be located such that City and applicable Utility Company's standard clearance criteria with other infrastructure is achieved, and such that new sewer installations are coordinated with installation of other Utility Infrastructure.

- C. All new sewers shall be located outside the LRT Zone of Influence. All new sewers crossing the LRT right-of-way shall be installed inside a casing pipe. Casing spacers and water tight end seals at both ends of the basing pipe should be installed.
- D. All new Minor Drainage systems located in combined sewer service areas shall discharge into the existing EPCOR Water Services Inc. (Drainage) storm sewer system where a storm system is available. Discharge to the EPCOR Water Services Inc. (Drainage) combined sewer system will be permitted only when an EPCOR Water Services Inc. (Drainage) storm sewer system is not available.
- E. All new sewer infrastructure shall be furnished using new materials only. Re-use of materials is not allowed.

3-5.8.2 Supplemental Drainage Standards

A. The following clauses supplement the *EPCOR Drainage Design and Construction Standards, Volume 3: Drainage (August 2020)*.

1. Supplemental to Section 14.5 Location of Drainage Inlets:
 - a. drainage inlets shall not be placed on mainline sewers; and
 - b. drainage inlets shall not be placed at locations where they are prone to damage by vehicular traffic or other street maintenance equipment, including within the wheel paths of vehicular traffic.
2. Supplemental to Section 19.2.3 General Sewer Materials Requirements:
 - a. All sanitary sewers and combined sewers shall be PVC (PSM Type) SDR35 conforming to CSA B182.2, ASTM D3034, and ASTM F679 standards with minimum stiffness of 320 kPa. Sealing gaskets shall meet requirements of CSA B182.2 and ASTM F477 and withstand up to 345 kPa hydrostatic pressure. Concrete pipes with PVC or HDPE liner could be used for sanitary or combined sewers.
 - b. All storm sewers greater than 1200 mm diameter shall be concrete pipe in accordance with CSA A257.2 made with type HS high sulphate resistant Portland cement, with flexible rubber gasket joints to CSA A257.3.
 - c. All storm sewers 1200 mm diameter or less shall be PVC (PSM Type) SDR35 conforming to CSA B182.2, ASTM D3034, and ASTM F679 standards with minimum stiffness of 320 kPa. Sealing gaskets shall meet requirements of CSA B182.2 and ASTM F477 and withstand up to 345 kPa hydrostatic pressure.
 - d. The approved pipe materials for trenchless construction sections are fiber reinforced polymer pipes (HOBAS or Flowtite) and concrete pipes with PVC or HDPE liner.
 - i. All pipes shall be designed to support the worst-case combinations of externally and internally imposed loads including but not limited to earth, traffic, hydrostatic and pipe jacking force, etc., with minimum factor of safety of 2 and have a minimum service life of 100 years.
 - ii. The mechanical strength of the pipe shall be adequate to resist any tensile or bending stresses anticipated to be imposed upon the pipe during the installation process.
 - iii. The total external pressure on the pipe shall include an allowance for AASHTO HS25 concentrated live load, CSA S6CL800 load. If the pipe crosses under the LRT track, minimum live load surcharge shall be calculated based on worst combination of LRT live load, truck load, earth load, etc. for the portion of the pipe affected by that loading.

- iv. All material specifications, relevant manufacturers' documents and design drawings, stamped by a professional engineer licensed to practice in the province of Alberta shall be submitted to the City.
- 3. Supplemental to Section 19.6.1 General Manhole Requirements:
 - a. Type 6A manhole frame and cover shall be used for 1200 mm manholes structures
- 4. Supplemental to Section 19.5.3 Location of Manholes:
 - a. manholes are to be located to allow for operation and maintenance access; and
 - b. manholes are not to be located in locations that prohibit access such as behind walls or structures or within planting beds.
- 5. Supplemental to Section 19.7.2 Catch Basin Lead Arrangement:
 - a. catch basins may connect to a manhole or catch basin manhole but catch basin manholes must connect to a manhole - long chains of catch basin-to-catch basin manhole-to-catch basin manhole are not permitted;
 - b. catch basin leads shall not be placed in parallel or below the curb and gutter; and.
 - c. catch basin leads shall be located within the roadway - installations below sidewalks are not permitted.
- 6. Supplemental to Section 21.2 Engineering Drawing Requirements, plan-profile drawings shall be submitted for all sections of mainline sewer installations.
- 7. Supplemental to Section 02958 Leakage Testing of Sewers:
 - a. Leakage testing is not required for sewer installations that include the connection of existing services. Leakage testing is required for all sewer installations where no existing services are connected to the mainline sewer.
- B. Construction with Live Sewer Flow and Flow Bypass:
 - 1. Working with live sewers is required for this Project. Flow bypass or diversion is required when installing or connecting the existing pipes to the new pipes/manholes and/or replacing existing manholes.
 - 2. Project C. is responsible for the design, installation and operation of temporary flow bypass system during construction. Project Co shall submit flow bypass plans designed and stamped by a Professional Engineer to the City for review and acceptance prior to implementation.
 - 3. Bypass plans and designs shall be in accordance with City of Edmonton Design and Construction Standards, City of Edmonton Drainage Bylaw and EPCOR Drainage Bylaws.
- C. Non-Standard Drainage Products:
 - 1. standard City of Edmonton drainage products are to be used; and
 - 2. non-standard drainage products shall not be used unless approved by the City. It is Project Co's responsibility to submit all product information to the City for product approval.

Section 3-6 UTILITIES

3-6.1 GENERAL

3-6.1.1 Scope

- A. This Section 3-6 [*Utilities*] sets out the technical requirements for all temporary and permanent Utility Work. Refer to Schedule 28 [*Project Approvals and Utility Matters*] for the administrative protocols to be followed in coordinating, proceeding, and completing Utility Work.
- B. Project Co shall confirm the location of, protect and avoid interruption of all existing Utility Infrastructure and existing Utility Service Connections that may be affected by the Project Work, unless approved in writing by the applicable Utility Company or the City as the property owner, as applicable, and in compliance with any conditions imposed in the applicable approval.

3-6.1.2 Codes & Standards

- A. Without limiting Section 1-1.7 [*Reference Documents*] of this Schedule and except as otherwise specified herein, the Utility Work and all associated infrastructure shall comply with the following codes, standards and regulations:
 - 1. all codes, standards, and regulations applicable to Utility Work;
 - 2. codes and standards identified in the applicable Utility Agreements, copies of which are included in the Disclosed Data;
 - 3. CSA Z662; and
 - 4. City design and construction standards including Utilities, including:
 - a. Volume 1: General, July 2020;
 - b. Volume 1: Table of Minimum Offsets (Excel version), July 2020;
 - c. Volume 2: Complete Streets Design and Construction* (Roadways), October 2018;
 - d. Volume 3: Drainage, August 2020;
 - e. EPCOR Design Standards Volume 4: Water, March 2017;
 - f. EPCOR Water Services Guidelines;
 - g. City of Edmonton Road and Walkway Lighting Design Manual; and
 - h. EPCOR Design and Construction Standards Volume 7: Underground Power Distribution Systems, August 2019;
 - i. EPCOR Customer Connection Guide
- B. Materials incorporated into the Utility Work shall be approved by the relevant Utility Company prior to installation.

3-6.1.3 Design and Construction Principles

- A. Design and Construction of the Utility Work shall be on a like-for-like basis, unless an alternative standard has been agreed to with the relevant Utility Company or as otherwise specified by another provision of this Schedule.

- B. Make arrangements with and obtain the necessary new Utility Service Connections for operation and maintenance of the Infrastructure from the applicable Public Utility Company. Confirm equipment compatibility and interoperability in compliance with each applicable Public Utility Company's connection requirements.
- C. Project Co shall comply with the Stray Current Program and co-ordinate with the Utility Companies to protect the Utility Infrastructure from corrosion exposure. Public Utility Companies will be responsible for design and construction of corrosion protection for their own Public Utility Infrastructure. Project Co will be responsible for design and construction of corrosion protection for Pipeline Infrastructure.
- D. Project Co shall not impede the flow in existing water services, sewers, drains and water courses encountered in conjunction with the Construction. Effluent from drains shall not flow into an open trench. Interruption of power or telecommunication services shall not be permitted without written approval of the customer and Public Utility Company providing the specific service, as applicable.
- E. The Infrastructure shall be designed and constructed such that it shall not impede the future replacement or repair of Utility Infrastructure.
- F. A minimum of 1m vertical separation shall be maintained between any soil disturbance or the Infrastructure, and Pipeline Infrastructure, unless the applicable Pipeline Agreement specifically identifies a different clearance requirement.
- G. Utility Best Practices shall be employed, in particular the use of design phase field investigations to inform designs.
- H. As EPCOR Water Services Inc. maintains exclusive jurisdiction over water infrastructure to construct or alter all municipal water infrastructure within existing road ROW, and for Valley Line West, property to be acquired by the City and converted to road ROW, Project Co shall ensure sufficient advance notification and details regarding impacts to existing or new water infrastructure are provided to EPCOR Water for them to perform their work.
- I. Retention of existing Utilities within the Zone of Influence and parallel to the trackway or placement of new Utilities within the Zone of Influence and parallel to the trackway shall be considered only where future access to the Utility by the Utility Company would not cause an interruption of LRT operations and shall be validated via an accepted variance agreed to by Project Co, the City, and the Utility Company.

3-6.1.4 Project Co Utility Work

3-6.1.4.1 General

- A. For Utility Work to be undertaken by Project Co:
 - 1. obtain all required Project Approvals, including rights of entry or access agreements;
 - 2. liaise, arrange, and coordinate with Utility Companies, Governmental Authorities, and other interested parties in connection with Utility Work;
 - 3. observe and comply with any instructions or directions including meeting advance notification requirements, as listed in the Disclosed Data, relating to Utility Work issued by the Utility Company or any Governmental Authority with jurisdiction over the Utility Infrastructure including:
 - a. secured access to Utility Infrastructure;
 - b. operation of Utility Infrastructure;
 - c. monitoring/inspection by a Utility Company; and

- d. protection of Utility Infrastructure; including the design, installation and removal of temporary supports as required to protect Utility Infrastructure where a Utility Company would permit temporary exposure of Utility Infrastructure;
 - 4. secure, or cause to be secured, entry into or execution of all relevant construction or other agreements required in connection with Utility Work;
 - 5. secure and protect Utility Work from deleterious material intrusion;
 - 6. give such notices as required by the relevant Utility Company and pre-arrange for Utility Company inspections/monitoring of investigations or construction activities as required;
 - 7. identify, design, coordinate, and construct any Utility Work and any upgrades to existing Utility Infrastructure that may be required to service the System; and
 - 8. identify, design, coordinate, construct, and remove any temporary Utility Infrastructure that may be required to accommodate the Design or Construction of the Infrastructure.
- B. Project Co shall develop, implement and maintain a system for retaining and tracking design submissions, applications, agreements, correspondence, quality control and quality assurance documentation with respect to all Project Co Utility Work. The system shall be capable of being interrogated remotely by the City.
- C. Project Co shall map all Utility Infrastructure in accordance with CSA S250-11 CAD base files, drawing submissions, and designs depicting mapping information and shall be maintained, shared and submitted in accordance with type of submission being made or information being shared, including for the Pre-ULA and ULA Processes. All Utility Work and Pipeline Work drawings shall comply with the City cadastral convention as set out in Section 1 *[Drafting Guidelines and Instructions]* of Appendix 4C *[Project Drawing Standards]* of Schedule 4 *[Design and Construction Protocols]* and shall differentiate between the status of Utility Infrastructure, including “abandoned” and “inactive”. Where the standard scale of drawings employed is insufficient to accurately distinguish between utility facilities the next larger standard scale shall be employed.

3-6.1.4.2 Tie-ins and Utility Crossings

- A. Project Co shall not undertake tie-ins to operational mains unless expressly approved in writing by the applicable Public Utility Company:
- 1. Water – EPCOR Water;
 - 2. Power – EPCOR D&T;
 - 3. Gas – ATCO Gas; and
 - 4. Telecommunications – applicable service Public Utility Company or department of the City of Edmonton.
- B. Installation of Utility Infrastructure that will cross the Trackway shall be designed and constructed as close to perpendicular as is possible to the Trackway. Track, road and pedestrian crossings of Pipeline Infrastructure shall not be less than 45 degrees. Where casing is installed at locations where Utility Infrastructure crosses the Trackway, it shall be continuous and extend at least 4 m beyond the Track centreline, or greater if required by another provision of this Schedule, and where possible, casing pipe shall be comprised of non-ferrous materials, or otherwise be provided with suitable cathodic and corrosion protection. Casing pipes shall accommodate all loads and settlements of the Trackway, and shall have a Design Service Life of at least 100 years.

3-6.1.4.3 Utility Trenches

- A. Project Co shall backfill utility trenches in accordance with the Utility Company specifications or applicable City infrastructure guidelines applicable; whichever is higher..
- B. Final Roadway restoration shall be in accordance with Section 3-2 [*Roadways, Sidewalks and Shared Use Paths*] of this Schedule.
- C. Project Co shall design, install, and remove any required temporary support structures where exposing Utility Infrastructure to the satisfaction of the applicable Utility Company, including signed and stamped engineered designs.

3-6.1.5 Utility Service Connections

- A. Project Co shall investigate to confirm all existing public utility service connections, identify and mitigate conflicts.
- B. Project Co shall be responsible for all alterations required to modify or replace existing public utility service connections, including any infrastructure required to support the connection, arising from modifications required to accommodate the Infrastructure, regardless of who performs the work.
- C. Project Co shall apply for, coordinate and construct new Utility Service Connections required for operation and Maintenance of the System, including performing any field investigations and identifying all conflicts with the Construction.
- D. All new Utility Service Connections shall be installed underground and within the Lands on public property.

3-6.2 ACCESS TO AND PROTECTION, ABANDONMENT AND REMOVAL OF UTILITY INFRASTRUCTURE

- A. Project Co shall not access Utility Infrastructure except with the prior consent of the applicable Utility Company.
- B. If Utility Infrastructure is deemed redundant by a Utility Company, Project Co may abandon or remove it as specifically approved by the Utility Company in accordance with agreed upon limits and terms. Approved abandonment or removal work shall be undertaken by Project Co.
- C. Existing Utility Infrastructure may contain Hazardous Substances. Project Co shall identify and properly dispose of redundant Utility Infrastructure materials encountered in compliance with Schedule 10 [*Environmental Performance Requirements*].

3-6.3 UTILITY INFRASTRUCTURE REPAIRS

- A. Where Project Co encounters as part of the Project Work existing Utility Infrastructure in poor condition, Project Co shall notify the Utility Company verbally and in writing and afford the Utility Company an opportunity to investigate. The Utility Company shall be afforded such time and access to make repairs as can be reasonably accommodated within the Construction Schedule.
- B. Where replacement of Utility Infrastructure that is found to be in poor condition forms part of the Project Work, Project Co shall complete repairs to the Utility Infrastructure to a location agreed upon with the applicable Utility Company, extending no further than the next logical connection point that would afford the Utility Company the ability to undertake future repairs without affecting Construction Schedule or the operations by others.

3-6.4 PIPELINE CROSSING RECORDS

- A. At each location where Utility Work or other Project Work is adjacent to or on Pipeline Company property, a pipeline crossing record shall be kept and shall contain the following:
1. name and phone number of the Pipeline Company field representative;
 2. special provisions of the Pipeline Agreement;
 3. records of:
 - a. calls to the Pipeline Company field representative;
 - b. Pipeline Company field representative visits – time, date, comments, and signature;
 - c. City representative visits – time, date, comments, and signature; and
 - d. Project Co's superintendent's comments or observations related to work on or adjacent to Pipeline Company property; and
 4. commencement and completion dates of Utility Work or other Project Work on or adjacent to Pipeline Company property.

Section 3-7 STREET LIGHTING REQUIREMENTS

3-7.1 SCOPE

- A. This section sets out the requirements for all Street Lighting, except:
1. Under-bridge lighting of the Anthony Henday Drive Bridge which is set out in Section 4-3.3 [*Anthony Henday Drive LRT Bridge*] of this Schedule.
- B. Lighting requirements for other elements of the Valley Line West LRT can be found in the following sections of this Schedule:
1. Stops: Section 2-6 [*Lighting*] of this Schedule
 2. Stations: Section 2-6 [*Lighting*] of this Schedule
 3. Gerry Wright OMF Site: Section 8-2 [*Gerry Wright OMF*] of this Schedule
 4. Lewis Farms Storage Facility: Section 8-3 [*Lewis Farms Storage Facility*] of this Schedule; and
 5. Decorative secondary lighting for Roadways, sidewalks and SUPs: Section 2-6 [*Lighting*] of this Schedule.
- C. Further requirements for Street Lighting are set out in Section 2-6 [*Lighting*] and Section 6-6 [*Street Lighting System Requirements*] of this Schedule.

3-7.2 DESIGN BASIS AND CRITERIA

- A. Without limiting Section 1-1.7 [*Reference Documents*] of this Schedule and except as otherwise specified herein, the Street Lighting shall comply with the requirements of the following codes, standards and regulations:
1. Valley Line West LRT Road and Walkway Lighting Construction and Material Standards;
 2. Valley Line West LRT Road and Walkway Lighting Design Manual;
 3. Light Efficient Community Policy (C576);
 4. TAC Guide for the Design of Roadway Lighting; and
 5. IESNA RP-8-00 Roadway Lighting.
- B. Without limiting Section 1-1.7 [*Reference Documents*] of this Schedule and except as otherwise specified herein, Street Lighting within the TUC shall comply with the requirements of the Alberta Transportation Highway Lighting Guide
- C. In the event of any conflict, ambiguity or inconsistency between or among the requirements of the above listed codes, standards and regulations, the requirements shall apply in the order listed in Section 3-7.2.1A [*Design Standards*].

3-7.3 DESIGN SPECIFIC REQUIREMENTS

3-7.3.1 General

- A. Without limiting the requirements of Section 3-7.1 [*Scope*] and 3-7.2 [*General*] of this Schedule, this Section 3-7.3 [*Design Specific Requirements*] sets out additional requirements for the Street Lighting of specific areas.

3-7.3.2 Roadways, Sidewalks and SUPs

- A. Except as otherwise specified in this Schedule, provide new lighting along all Roadways, sidewalks and SUPs, in accordance with the *Valley Line West LRT Road and Walkway Lighting Construction and Material Standards*, a copy of which is included in the Disclosed Data, and the *TAC Guide for the Design of Roadway Lighting*.
- B. Lighting shall comply with the *City of Edmonton Light Efficient Community Policy (C576)*, including the corresponding *City Procedure* and *Attachment 1*.
- C. Lighting systems for all Roadways, sidewalks, bridges and SUPs within the TUC shall comply with the *Alberta Transportation Highway Lighting Guide*.
- D. Luminaires may be mounted on the OCS poles in accordance with Section 3-3.3.10 [*Poles*] of this Schedule.
- E. Notwithstanding the requirements of Section 4-3.3 [*Anthony Henday Drive LRT Bridge*] of this Schedule, Street Lighting shall not be built on top of or attached to any Transportation Structures other than where it is mounted on the OCS poles.

3-7.3.3 WEM Transit Centre

- A. Within WEM Transit Centre provide lighting systems at:
 - 1. bus loading/unloading areas;
 - 2. Passenger pick-up and drop-off areas (Kiss and Rides);
 - 3. entrances and exits;
 - 4. shelters and waiting areas;
 - 5. along pedestrian paths, including SUPs;
 - 6. crosswalks; and
 - 7. cycle parking areas.
- B. Lighting systems within WEM Transit Centre shall be designed so that the failure of any single luminaire or lighting circuit does not leave an area accessible to the public with less than half the minimum illumination levels specified in the *TAC Guide for the Design of Roadway Lighting*.

3-7.3.4 Lewis Farms Park and Ride

- A. Within Lewis Farms Park and Ride provide lighting systems at:
 - 1. bus loading/unloading areas;
 - 2. Passenger pick-up and drop-off areas (Kiss and Rides);
 - 3. entrances and exits;
 - 4. parking areas;
 - 5. shelters and waiting areas;
 - 6. along pedestrian paths, including SUPs;
 - 7. crosswalks;
 - 8. track crossings;
 - 9. cycle parking areas; and

10. along internal access roads.

- B. Lighting systems within Lewis Farms Park and Ride shall be designed so that the failure of any single luminaire or lighting circuit does not leave an area accessible to the public with less than half the minimum illumination levels specified in the TAC Guide for the Design of Roadway Lighting.
- C. Lighting shall be sufficient to meet the lighting requirements of the Lewis Farms Park and Ride. However, light trespass values shall be zero at ground level at the boundary to the Muskakosi Natural Area. This includes SUP lights for SUPs adjacent to the Muskakosi Natural Area surrounding and accessing the Lewis Farms Park and Ride.
- D. Lighting within the Lewis Farms Temporary Parking Facility shall be on temporary wooden poles with all cabling above ground. The existing street lighting within the Lewis Farms Temporary Parking Facility may be retained or relocated on the Lewis Farms Temporary Parking Facility as required by the stall configuration.

3-7.3.5 Stony Plain Road/124 Street

- A. With reference to Section 1-7.5 [*Deconstruction Requirements*] of this Schedule, reinstall four existing (4) pedestrian light poles at the intersection of Stony Plain Road and 124 Street, one (1) at each of the four (4) intersection corners, such that the materials and components are not damaged during the reinstallation.
- B. Notwithstanding Section 3-7.3.5A [*Stony Plain Road/124 Street*] of this Schedule, the remaining existing pedestrian light poles that are located on Stony Plain Road between 125 Street and 124 Street and between 124 Street and 123 Street need not be re-instated.
- C. All Traffic Signal Equipment, including cantilever structures, poles, arms, davit extensions, and luminaires, required at the intersection of 124 Street and Stony Plain Road shall be coated Black (colour code RAL 9011) in accordance with Section 2.2 [*Coatings for Galvanized Steel (B2010.10)*] of the Valley Line West LRT Facilities Design and Construction Standards.

3-7.3.6 Anthony Henday Drive

- A. Restore street lighting along Anthony Henday Drive to match existing street lighting levels.

3-7.3.7 104 Street Streetscape Lighting

- A. The existing power distribution cabinet at the northwest corner of the intersection of 104 Street and 102 Avenue, servicing streetscape lighting on 104 Street, shall be relocated to a public realm location outside of the walkway, acceptable to the City.

APPENDIX 5-3A

Access and Road Closure Drawings

(see attached)

AA\AMND / September 8, 2020 / \MED\FILER\ISL\GLOBAL\PROJECTS\140001480014854_VALLEY_LINE_LRT_WEST_DESIGN_OE\02_CADD\3D_DRAFTING\2300_ROADWAY\506_STAGE 2 ACCESS & ROAD CLOSURES\5-3A-01.DWG



NOTES:
 1. ACCESS CLOSURES, ROAD CLOSURES AND CONNECTION REMOVALS TO BE COORDINATED BY PROJECT CO IN ACCORDANCE WITH SPECIFICATIONS IN PROJECT AGREEMENT
 2. NEW ACCESSSES TO BE DESIGNED AND CONSTRUCTED BY PROJECT CO

LEGEND

ACCESS CLOSURE		CONNECTION REMOVAL	
NEW ACCESS		ROAD CLOSURE	

no.	description	date	checked
2	RFP V4	18-09-20	JM
1	RFP V3	07-23-20	JM
0	RFP	02-21-20	JM
revisions			

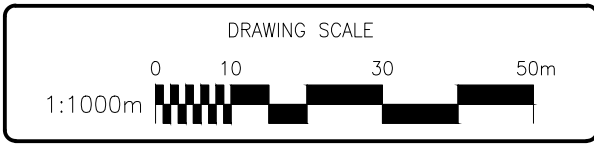

NOT FOR CONSTRUCTION



ACCESS, ALLEY & ROAD CLOSURES

DRAWING NO: 5-3A-01

VALLEY LINE WEST LRT

AAAMND / September 8, 2020 / I:\EDM\FILERS\GLOBAL\PROJECTS\140001480014854_VALLEY_LINE_LRT_WEST_DESIGN_OE\02_CADD\00_DRAFTING\2300_ROADWAY\06_STAGE 2 ACCESS & ROAD CLOSURES\5-3A-02.DWG

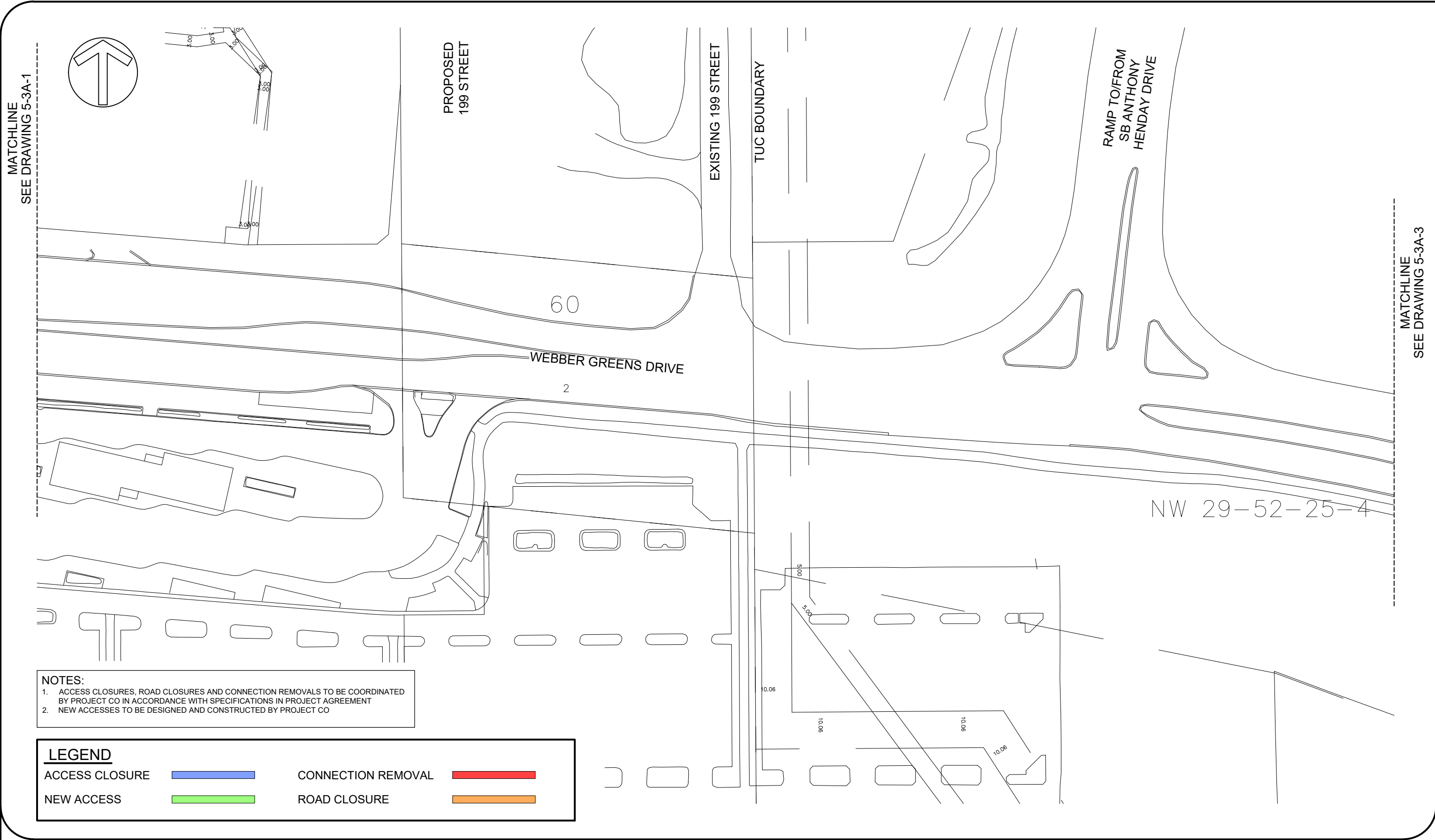

NOTES:
 1. ACCESS CLOSURES, ROAD CLOSURES AND CONNECTION REMOVALS TO BE COORDINATED BY PROJECT CO IN ACCORDANCE WITH SPECIFICATIONS IN PROJECT AGREEMENT
 2. NEW ACCESSSES TO BE DESIGNED AND CONSTRUCTED BY PROJECT CO

LEGEND			
ACCESS CLOSURE		CONNECTION REMOVAL	
NEW ACCESS		ROAD CLOSURE	

no.	description	date	checked
2	RFP V4	18-09-20	JM
1	RFP V3	07-23-20	JM
0	RFP	02-21-20	JM
revisions			

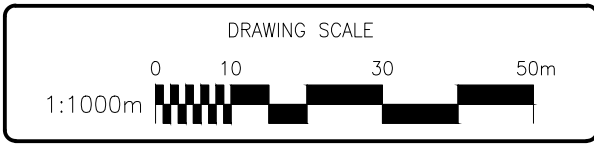

NOT FOR CONSTRUCTION

AECOM
Prime Consultant

Edmonton

HATCH

DIALOG

ISL Engineering

MOTT MACDONALD

ACCESS, ALLEY & ROAD CLOSURES

DRAWING NO: 5-3A-02

VALLEY LINE WEST LRT

AAAMND / September 8, 2020 / I:\EDM\FILERS\GLOBAL\PROJECTS\140001480014854_VALLEY_LINE_LRT_WEST_DESIGN_OE\02_CADD\00_DRAFTING\2300_ROADWAY\06_STAGE 2 ACCESS & ROAD CLOSURES\5-3A-03.DWG

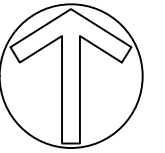

MATCHLINE
SEE DRAWING 5-3A-2

MATCHLINE
SEE DRAWING 5-3A-4

VALLEY LINE WEST LRT

NOTES:
1. ACCESS CLOSURES, ROAD CLOSURES AND CONNECTION REMOVALS TO BE COORDINATED BY PROJECT CO IN ACCORDANCE WITH SPECIFICATIONS IN PROJECT AGREEMENT
2. NEW ACCESSSES TO BE DESIGNED AND CONSTRUCTED BY PROJECT CO

LEGEND

ACCESS CLOSURE		CONNECTION REMOVAL	
NEW ACCESS		ROAD CLOSURE	

no.	description	date	checked
2	RFP V4	18-09-20	JM
1	RFP V3	07-23-20	JM
0	RFP	02-21-20	JM
revisions			

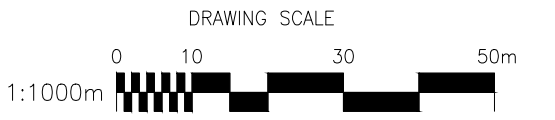

NOT FOR CONSTRUCTION

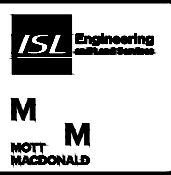

ACCESS, ALLEY & ROAD CLOSURES

DRAWING NO: 5-3A-03



TKL005 / September 15, 2020 / G:\PROJECTS\1400014864_VALLEY_LINE_LRT_WEST_DESIGN_DE02_CADD\20_DRAFTING\2300_ROADWAYS\06_STAGE 2 ACCESS & ROAD CLOSURES\5-3A-04.DWG

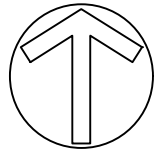

ACCESS CLOSURES			
ID	CLOSURE TYPE	STREET ADDRESS	PROPERTY TYPE
103-E	CONNECTION REMOVAL	SOUTH TUC	PROVINCIAL
103-G	NEW ACCESS	SOUTH TUC	PROVINCIAL

MATCHLINE
SEE DRAWING 5-3A-3

RAMP TO/FROM
NB ANTHONY
HENDAY DRIVE

103-G

103-E

TUC BOUNDARY

87 AVENUE

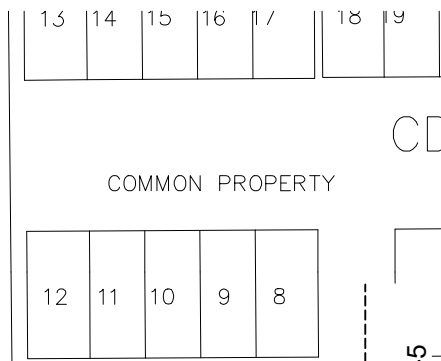

MATCHLINE
SEE DRAWING 5-3A-5

VALLEY LINE WEST LRT

LEGEND

- | | | | |
|----------------|--|--------------------|--|
| ACCESS CLOSURE | | CONNECTION REMOVAL | |
| NEW ACCESS | | ROAD CLOSURE | |

NOTES:

- ACCESS CLOSURES, ROAD CLOSURES AND CONNECTION REMOVALS TO BE COORDINATED BY PROJECT CO IN ACCORDANCE WITH SPECIFICATIONS IN PROJECT AGREEMENT
- NEW ACCESSSES TO BE DESIGNED AND CONSTRUCTED BY PROJECT CO

no.	description	date	checked
2	RFP V4	18-09-20	JM
1	RFP V3	07-23-20	JM
0	RFP	02-21-20	JM
revisions			

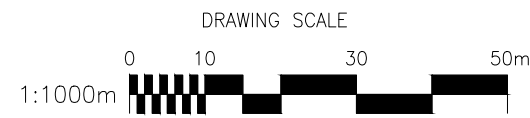

NOT FOR
CONSTRUCTION



ACCESS, ALLEY & ROAD CLOSURES

DRAWING NO: 5-3A-04

AA\AMND / September 8, 2020 / \MED\FILER\ISL_GLOBAL\PROJECTS\140001480014854_VALLEY_LINE_LRT_WEST_DESIGN_OE\02_CADD\30_DRAFTING\2300_ROADWAY\9\06_STAGE 2 ACCESS & ROAD CLOSURES\5-3A-05.DWG

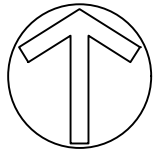

MATCHLINE
SEE DRAWING 5-3A-4

MATCHLINE
SEE DRAWING 5-3A-6



NOTES:
 1. ACCESS CLOSURES, ROAD CLOSURES AND CONNECTION REMOVALS TO BE COORDINATED BY PROJECT CO IN ACCORDANCE WITH SPECIFICATIONS IN PROJECT AGREEMENT
 2. NEW ACCESSES TO BE DESIGNED AND CONSTRUCTED BY PROJECT CO

LEGEND

ACCESS CLOSURE		CONNECTION REMOVAL	
NEW ACCESS		ROAD CLOSURE	

no.	description	date	checked
2	RFP V4	18-09-20	JM
1	RFP V3	07-23-20	JM
0	RFP	02-21-20	JM
revisions			

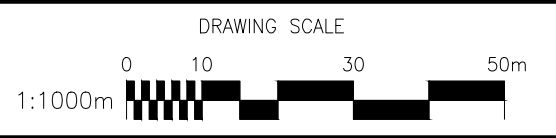

**NOT FOR
CONSTRUCTION**

AECOM
Prime Consultant

Edmonton

HATCH

DIALOG

ISL Engineering

MOTT MACDONALD

ACCESS, ALLEY & ROAD CLOSURES

DRAWING NO: 5-3A-05

VALLEY LINE WEST LRT

AA\AMND\September 8, 2020\1\EDM\FILER\ISL_GLOB\PROJECTS\140001480014854_VALLEY_LINE_LRT_WEST_DESIGN_OE\02_CADD\00_DRAFTING\2300_ROADWAY\06_STAGE 2 ACCESS & ROAD CLOSURES\5-3A-06.DWG

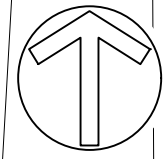

ACCESS CLOSURES			
ID	CLOSURE TYPE	STREET ADDRESS	PROPERTY TYPE
105-A	ACCESS	8660-182 AVENUE NW	RESIDENTIAL



NOTES:
 1. ACCESS CLOSURES, ROAD CLOSURES AND CONNECTION REMOVALS TO BE COORDINATED BY PROJECT CO IN ACCORDANCE WITH SPECIFICATIONS IN PROJECT AGREEMENT
 2. NEW ACCESSSES TO BE DESIGNED AND CONSTRUCTED BY PROJECT CO

LEGEND			
ACCESS CLOSURE		CONNECTION REMOVAL	
NEW ACCESS		ROAD CLOSURE	

ACCESS IS TO BE CLOSED TO ALL VEHICLES EXCEPT FOR EMERGENCY ACCESS

no.	description	date	checked
2	RFP V4	18-09-20	JM
1	RFP V3	07-23-20	JM
0	RFP	02-21-20	JM
revisions			

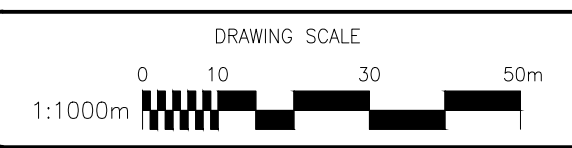

NOT FOR CONSTRUCTION



ACCESS, ALLEY & ROAD CLOSURES

DRAWING NO: 5-3A-06

VALLEY LINE WEST LRT

AA\AMND\September 8, 2020\1\EDM\FILER\ISL_GLOBAL\PROJECTS\140001480014854_VALLEY_LINE_LRT_WEST_DESIGN_OE\02_CADD\00_DRAFTING\2300_ROADWAY\9\06_STAGE 2 ACCESS & ROAD CLOSURES\5-3A-07.DWG

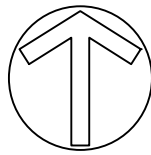

ACCESS CLOSURES			
ID	CLOSURE TYPE	STREET ADDRESS	PROPERTY TYPE
105-A	ACCESS	8660-182 AVENUE NW	RESIDENTIAL

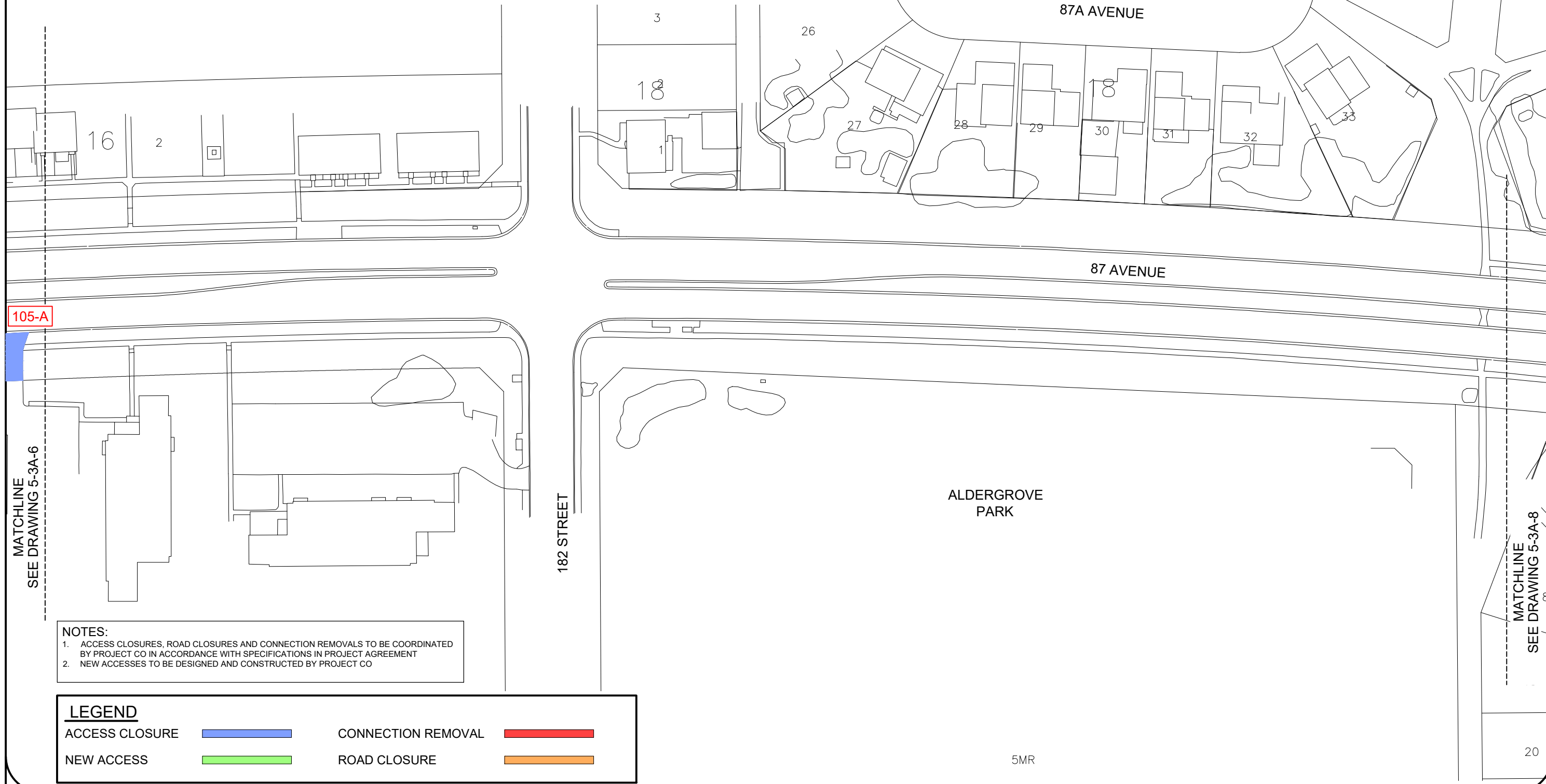

105-A

MATCHLINE
SEE DRAWING 5-3A-6

MATCHLINE
SEE DRAWING 5-3A-8

VALLEY LINE WEST LRT

NOTES:
 1. ACCESS CLOSURES, ROAD CLOSURES AND CONNECTION REMOVALS TO BE COORDINATED BY PROJECT CO IN ACCORDANCE WITH SPECIFICATIONS IN PROJECT AGREEMENT
 2. NEW ACCESSES TO BE DESIGNED AND CONSTRUCTED BY PROJECT CO

LEGEND			
ACCESS CLOSURE		CONNECTION REMOVAL	
NEW ACCESS		ROAD CLOSURE	

no.	description	date	checked
2	RFP V4	18-09-20	JM
1	RFP V3	07-23-20	JM
0	RFP	02-21-20	JM
revisions			

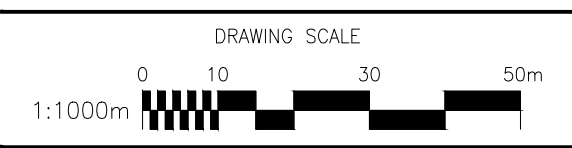

NOT FOR CONSTRUCTION

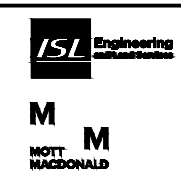

ACCESS, ALLEY & ROAD CLOSURES

DRAWING NO: 5-3A-07

A:\ANAND / September 8, 2020 / \MED\FILER\ISL\GLOBAL\PROJECTS\14000148001480014854_VALLEY_LINE_LRT_WEST_DESIGN_OE\02_CADD\00_DRAFTING\2300_ROADWAY\006_STAGE 2 ACCESS & ROAD CLOSURES\5-3A-08.DWG

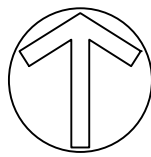

MATCHLINE
SEE DRAWING 5-3A-07



NOTES:
 1. ACCESS CLOSURES, ROAD CLOSURES AND CONNECTION REMOVALS TO BE COORDINATED BY PROJECT CO IN ACCORDANCE WITH SPECIFICATIONS IN PROJECT AGREEMENT
 2. NEW ACCESSSES TO BE DESIGNED AND CONSTRUCTED BY PROJECT CO

LEGEND			
ACCESS CLOSURE		CONNECTION REMOVAL	
NEW ACCESS		ROAD CLOSURE	

178 STREET

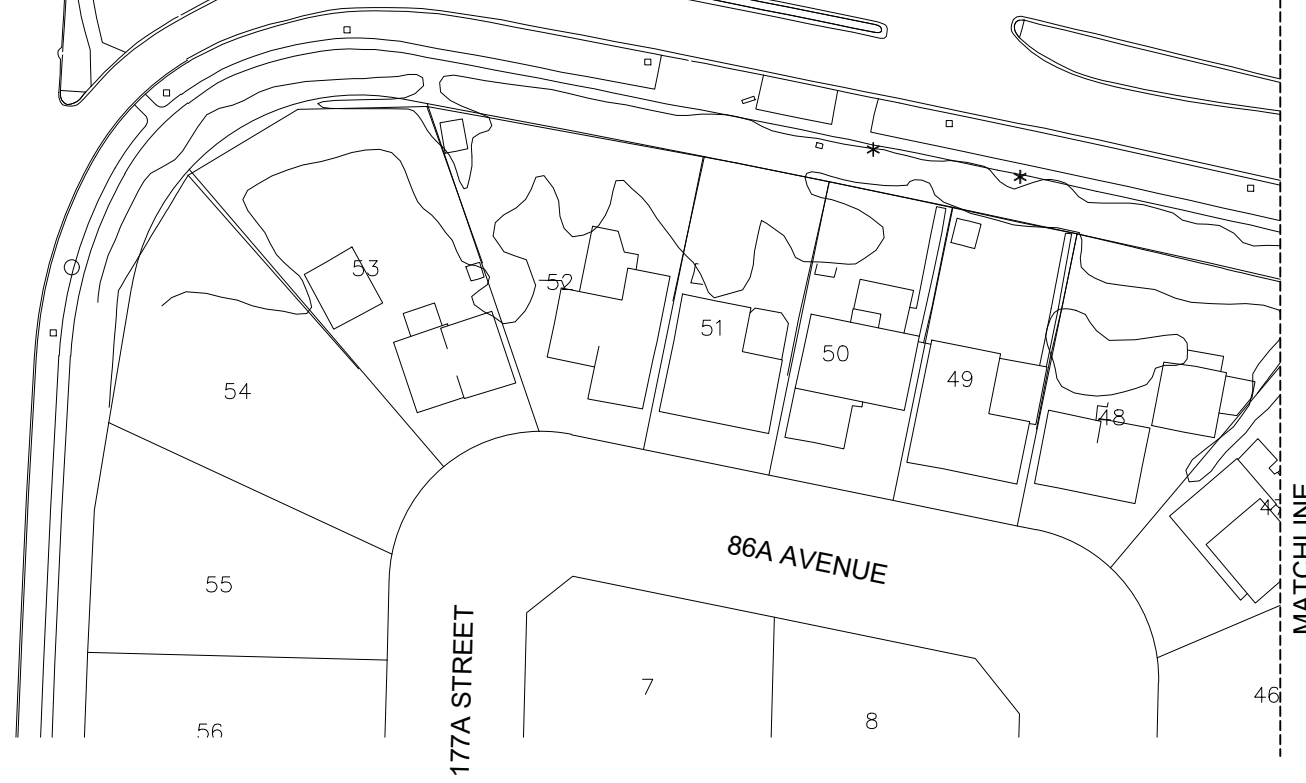
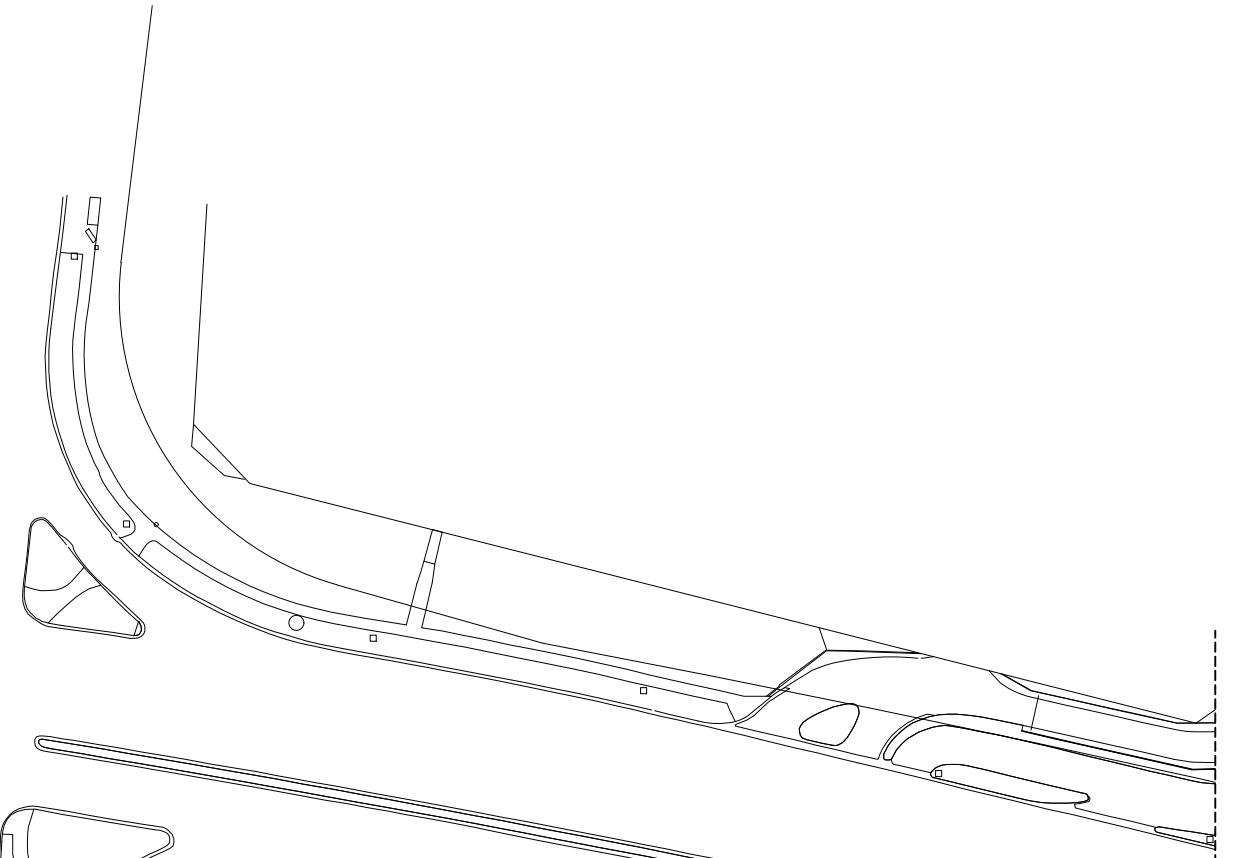

MATCHLINE
SEE DRAWING 5-3A-9

VALLEY LINE WEST LRT

no.	description	date	checked
2	RFP V4	18-09-20	JM
1	RFP V3	07-23-20	JM
0	RFP	02-21-20	JM
revisions			

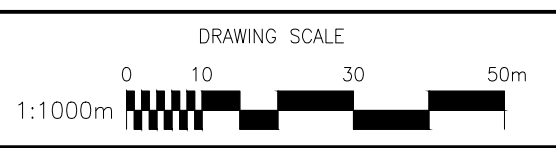

NOT FOR CONSTRUCTION



ACCESS, ALLEY & ROAD CLOSURES

DRAWING NO: 5-3A-08

A:\AMAND \September 8, 2020 \MEDFILLER\ISL\GLOBAL\PROJECTS\140001480014854_VALLEY_LINE_LRT_WEST_DESIGN_OE\02_CADD\00_DRAFTING\2300_ROADWAY\006_STAGE 2 ACCESS & ROAD CLOSURES\5-3A-09.DWG

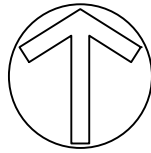

ACCESS CLOSURES			
ID	CLOSURE TYPE	STREET ADDRESS	PROPERTY TYPE
108-H	ACCESS	8623 - 175 STREET NW	RESIDENTIAL

MATCHLINE
SEE DRAWING 5-3A-8

MATCHLINE
SEE DRAWING 5-3A-10

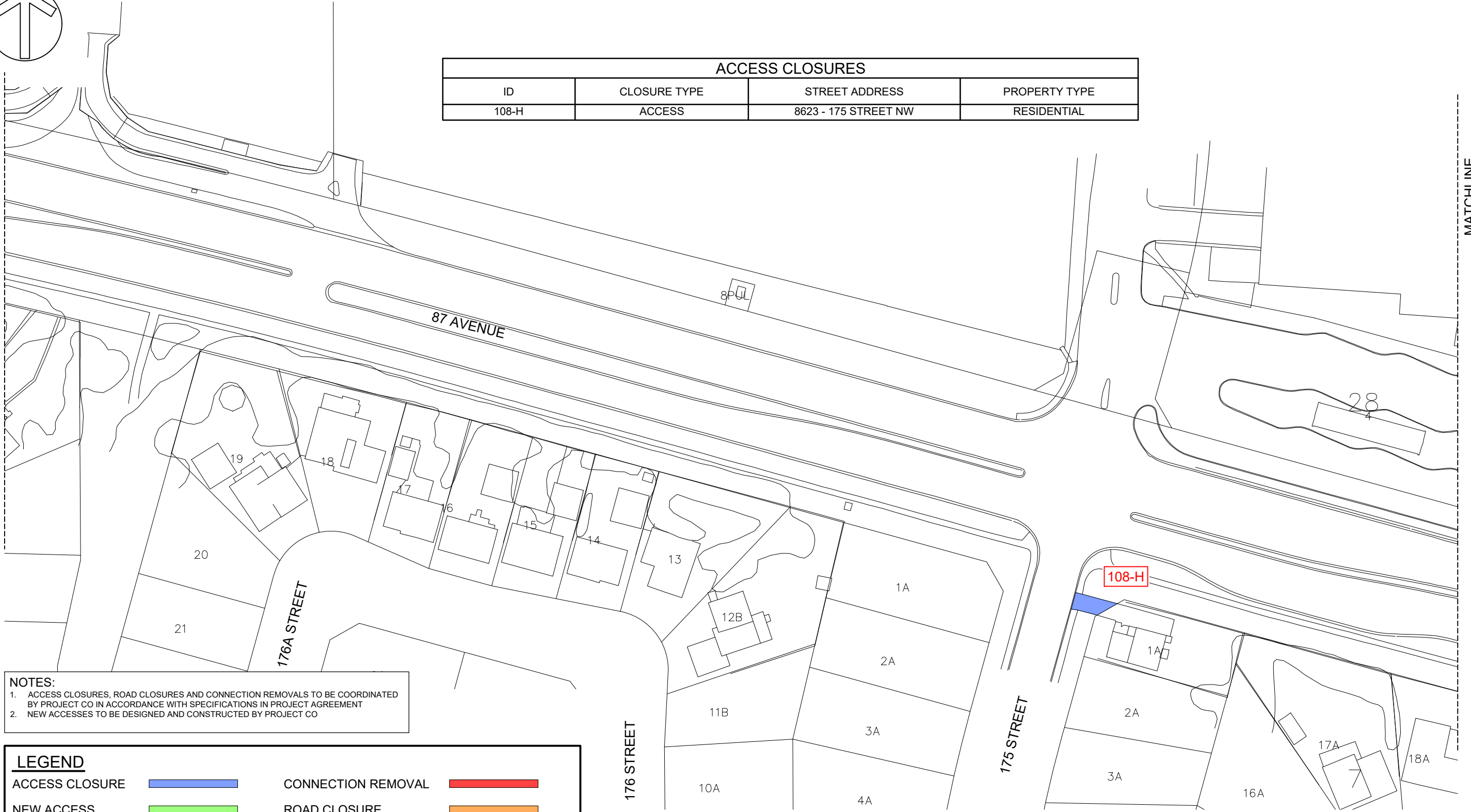

NOTES:
 1. ACCESS CLOSURES, ROAD CLOSURES AND CONNECTION REMOVALS TO BE COORDINATED BY PROJECT CO IN ACCORDANCE WITH SPECIFICATIONS IN PROJECT AGREEMENT
 2. NEW ACCESSSES TO BE DESIGNED AND CONSTRUCTED BY PROJECT CO

LEGEND			
ACCESS CLOSURE		CONNECTION REMOVAL	
NEW ACCESS		ROAD CLOSURE	

no.	description	date	checked
2	RFP V4	18-09-20	JM
1	RFP V3	07-23-20	JM
0	RFP	02-21-20	JM
revisions			

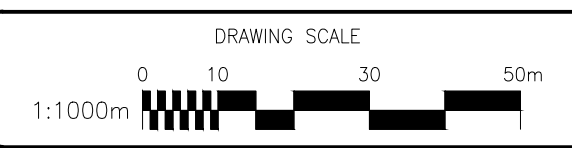

NOT FOR CONSTRUCTION



ACCESS, ALLEY & ROAD CLOSURES

DRAWING NO: 5-3A-09

VALLEY LINE WEST LRT

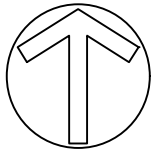

ACCESS CLOSURES			
ID	CLOSURE TYPE	STREET ADDRESS	PROPERTY TYPE
109-K	ACCESS	8624 - 172 STREET NW	RESIDENTIAL

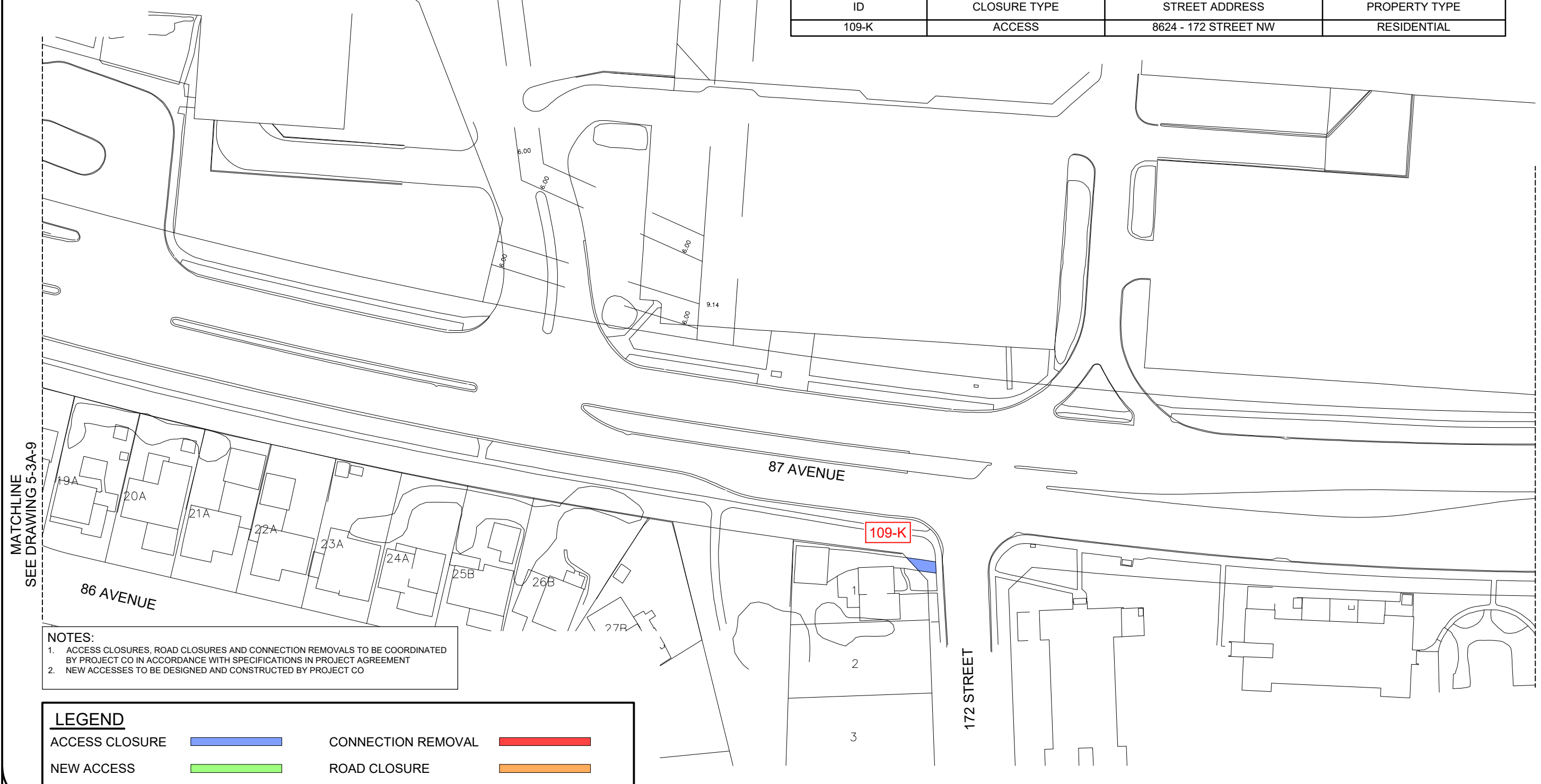

AA\AMND / September 8, 2020 / \MED\FILER\ISL_GLOBAL\PROJECTS\140001480014854_VALLEY_LINE_LRT_WEST_DESIGN_OE\02_CADD\00_DRAFTING\2300_ROADWAY\06_STAGE 2 ACCESS & ROAD CLOSURES\5-3A-10.DWG

MATCHLINE
SEE DRAWING 5-3A-9

MATCHLINE
SEE DRAWING 5-3A-11

VALLEY LINE WEST LRT

NOTES:
 1. ACCESS CLOSURES, ROAD CLOSURES AND CONNECTION REMOVALS TO BE COORDINATED BY PROJECT CO IN ACCORDANCE WITH SPECIFICATIONS IN PROJECT AGREEMENT
 2. NEW ACCESSES TO BE DESIGNED AND CONSTRUCTED BY PROJECT CO

LEGEND			
ACCESS CLOSURE		CONNECTION REMOVAL	
NEW ACCESS		ROAD CLOSURE	

no.	description	date	checked
2	RFP V4	18-09-20	JM
1	RFP V3	07-23-20	JM
0	RFP	02-21-20	JM
revisions			

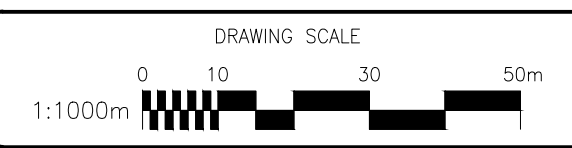

NOT FOR CONSTRUCTION



ACCESS, ALLEY & ROAD CLOSURES

DRAWING NO: 5-3A-10

AA\AMND / September 8, 2020 / \MED\FILER\ISL\GLOBAL\PROJECTS\140001480014854_VALLEY_LINE_LRT_WEST_DESIGN_OE\02_CADD\30_DRAFTING\2300_ROADWAY\9\06_STAGE 2 ACCESS & ROAD CLOSURES\5-3A-11.DWG

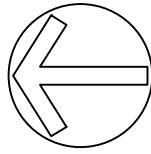

MATCHLINE
SEE DRAWING 5-3A-13

87 AVENUE

170 STREET





MATCHLINE
SEE DRAWING 5-3A-12

VALLEY LINE WEST LRT

NOTES:

1. ACCESS CLOSURES, ROAD CLOSURES AND CONNECTION REMOVALS TO BE COORDINATED BY PROJECT CO IN ACCORDANCE WITH SPECIFICATIONS IN PROJECT AGREEMENT
2. NEW ACCESSSES TO BE DESIGNED AND CONSTRUCTED BY PROJECT CO

LEGEND

- | | | | |
|----------------|---|--------------------|---|
| ACCESS CLOSURE |  | CONNECTION REMOVAL |  |
| NEW ACCESS |  | ROAD CLOSURE |  |

MATCHLINE
SEE DRAWING 5-3A-10

no.	description	date	checked
2	RFP V4	18-09-20	JM
1	RFP V3	07-23-20	JM
0	RFP	02-21-20	JM
revisions			

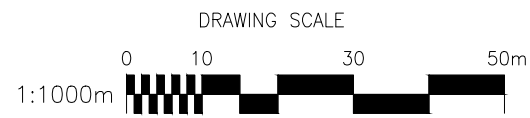

NOT FOR
CONSTRUCTION





ACCESS, ALLEY & ROAD CLOSURES

DRAWING NO: 5-3A-11

A:\ANAND\September 8, 2020\1\EDM\FILER\ISL\GLOBAL\PROJECTS\140001480014854_VALLEY_LINE_LRT_WEST_DESIGN_OE\02_CADD\30_DRAFTING\2300_ROADWAY\9\06_STAGE 2 ACCESS & ROAD CLOSURES\5-3A-12.DWG



NOTES:
 1. ACCESS CLOSURES, ROAD CLOSURES AND CONNECTION REMOVALS TO BE COORDINATED BY PROJECT CO IN ACCORDANCE WITH SPECIFICATIONS IN PROJECT AGREEMENT
 2. NEW ACCESSSES TO BE DESIGNED AND CONSTRUCTED BY PROJECT CO

LEGEND			
ACCESS CLOSURE		CONNECTION REMOVAL	
NEW ACCESS		ROAD CLOSURE	

no.	description	date	checked
2	RFP V4	18-09-20	JM
1	RFP V3	07-23-20	JM
0	RFP	02-21-20	JM
revisions			

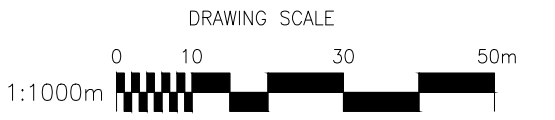

NOT FOR CONSTRUCTION

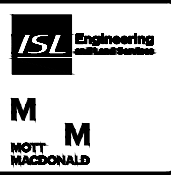

ACCESS, ALLEY & ROAD CLOSURES

DRAWING NO: 5-3A-12

VALLEY LINE WEST LRT

AA\AMND / September 8, 2020 / \MED\FILER\ISL\GLOBAL\PROJECTS\140001480014854_VALLEY_LINE_LRT_WEST_DESIGN_OE\02_CADD\00_DRAFTING\2300_ROADWAY\06_STAGE 2 ACCESS & ROAD CLOSURES\5-3A-13.DWG

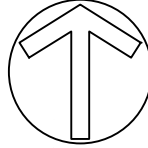

ACCESS CLOSURES			
ID	CLOSURE TYPE	STREET ADDRESS	PROPERTY TYPE
111-M	ROAD	BETWEEN 164 STREET NW and 169 STREET NW	PUBLIC

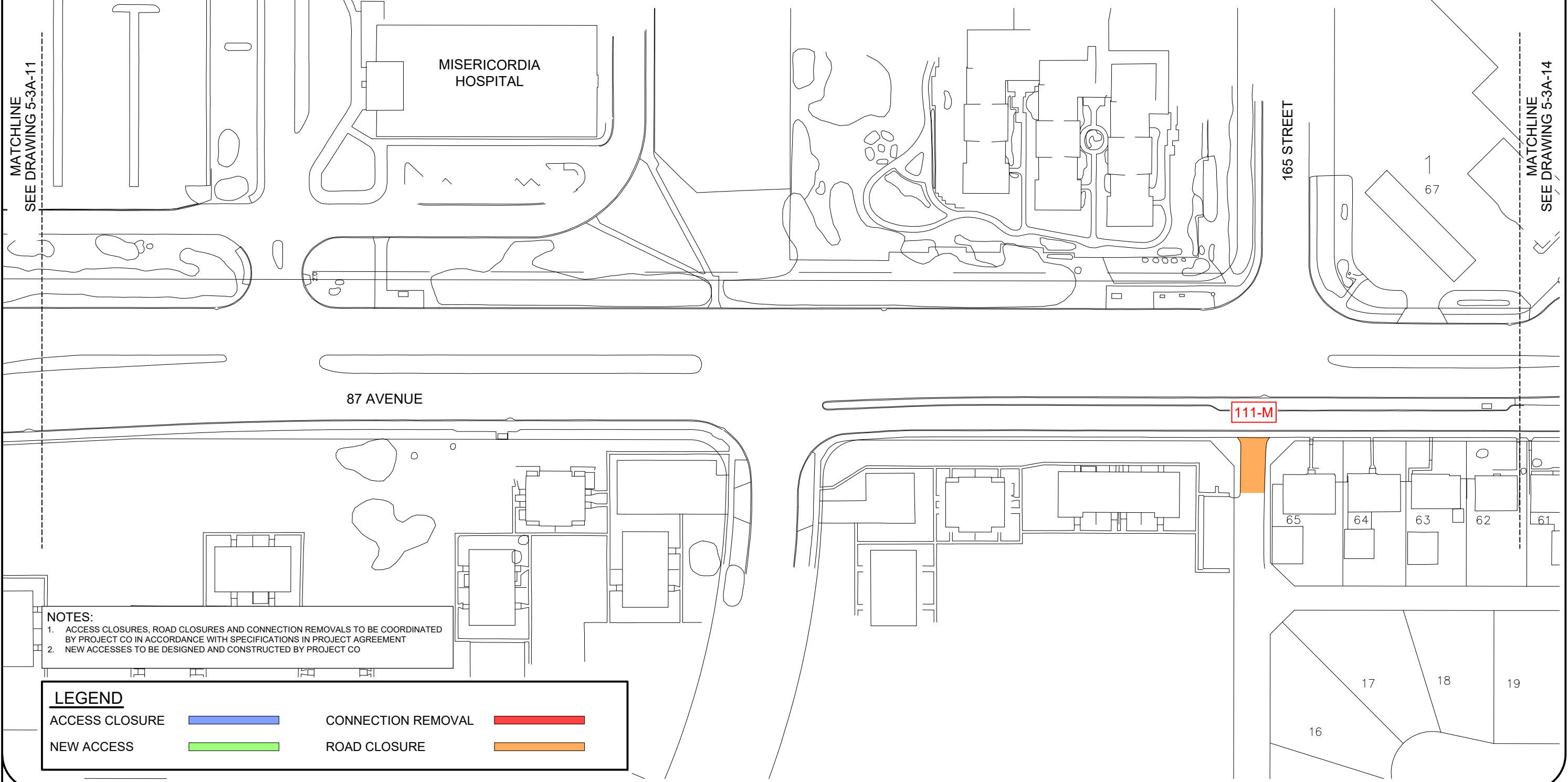

NOTES:
 1. ACCESS CLOSURES, ROAD CLOSURES AND CONNECTION REMOVALS TO BE COORDINATED BY PROJECT CO IN ACCORDANCE WITH SPECIFICATIONS IN PROJECT AGREEMENT
 2. NEW ACCESSES TO BE DESIGNED AND CONSTRUCTED BY PROJECT CO

LEGEND			
ACCESS CLOSURE		CONNECTION REMOVAL	
NEW ACCESS		ROAD CLOSURE	

no.	description	date	checked
2	RFP V4	18-09-20	JM
1	RFP V3	07-23-20	JM
0	RFP	02-21-20	JM
revisions			

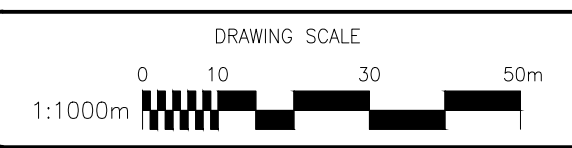

NOT FOR CONSTRUCTION



ACCESS, ALLEY & ROAD CLOSURES

DRAWING NO: 5-3A-13

VALLEY LINE WEST LRT

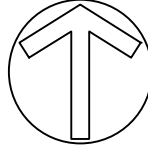

ACCESS CLOSURES			
ID	CLOSURE TYPE	STREET ADDRESS	PROPERTY TYPE
112-G	ACCESS	16315 - 87 AVENUE NW	RESIDENTIAL
112-H	ACCESS	16301 - 87 AVENUE NW	RESIDENTIAL
112-N	ACCESS	8606 - 164 STREET NW	RESIDENTIAL

MATCHLINE
SEE DRAWING 5-3A-13

VALLEY LINE WEST LRT

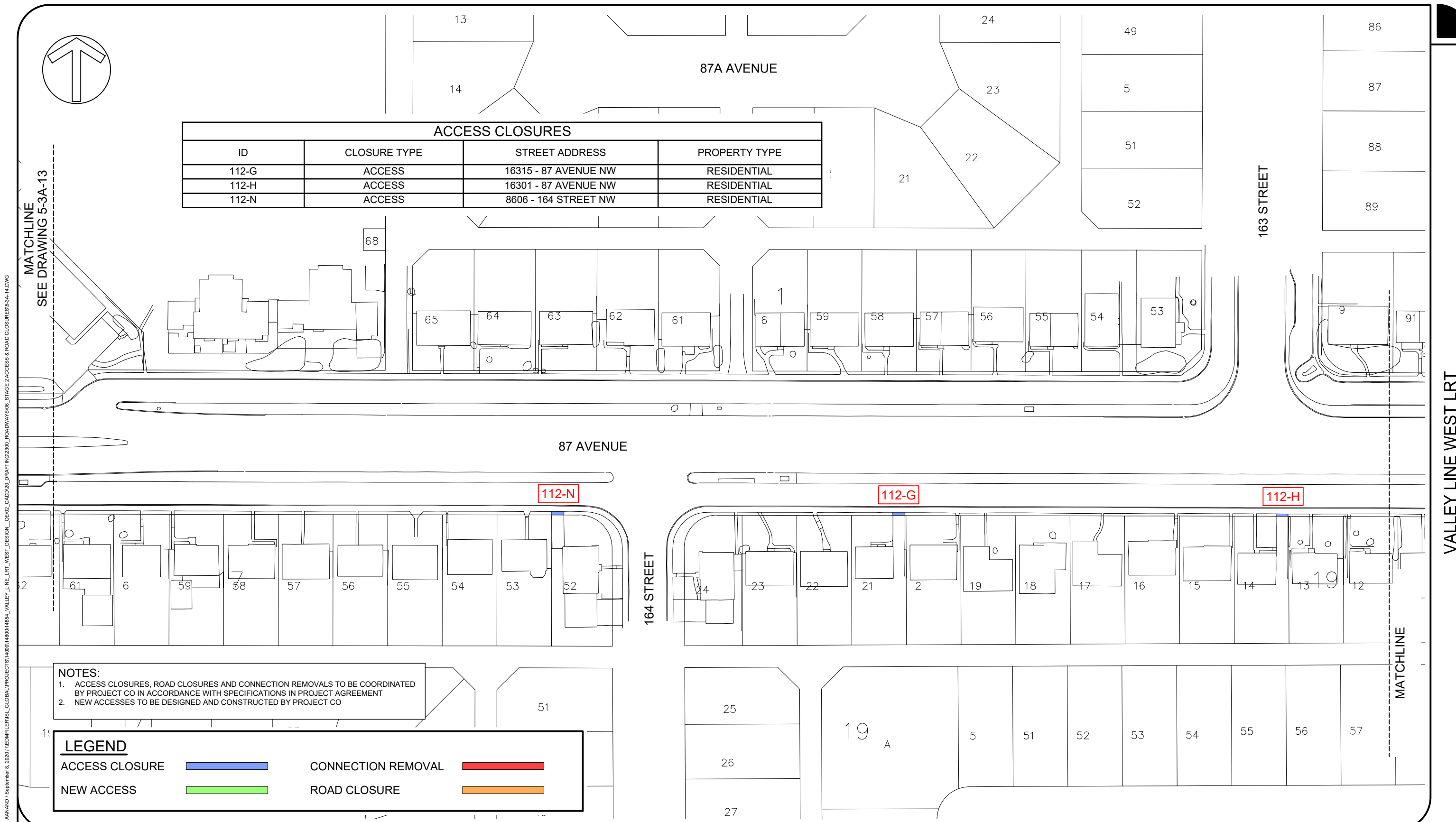

NOTES:
 1. ACCESS CLOSURES, ROAD CLOSURES AND CONNECTION REMOVALS TO BE COORDINATED BY PROJECT CO IN ACCORDANCE WITH SPECIFICATIONS IN PROJECT AGREEMENT
 2. NEW ACCESSSES TO BE DESIGNED AND CONSTRUCTED BY PROJECT CO

LEGEND			
ACCESS CLOSURE		CONNECTION REMOVAL	
NEW ACCESS		ROAD CLOSURE	

no.	description	date	checked
2	RFP V4	18-09-20	JM
1	RFP V3	07-23-20	JM
0	RFP	02-21-20	JM
revisions			

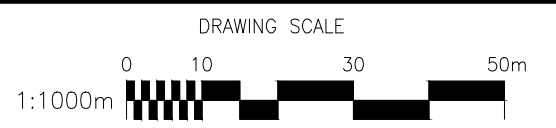

NOT FOR
CONSTRUCTION



ACCESS, ALLEY & ROAD CLOSURES

DRAWING NO: 5-3A-14

A:\ANAND\September 8, 2020\1\EDMONTON\GLOBAL\PROJECTS\140001\480014854_VALLEY_LINE_LRT_WEST_DESIGN_OE\02_CADD\00_DRAFTING\2300_ROADWAY\06_STAGE 2 ACCESS & ROAD CLOSURES\5-3A-14.DWG

AAAMND / September 8, 2020 / I:\EDM\FILERS\GLOBAL\PROJECTS\140001480014854_VALLEY_LINE_LRT_WEST_DESIGN_OE\02_CADD\30_DRAFTING\2300_ROADWAY\06_STAGE 2 ACCESS & ROAD CLOSURES\5-3A-15.DWG

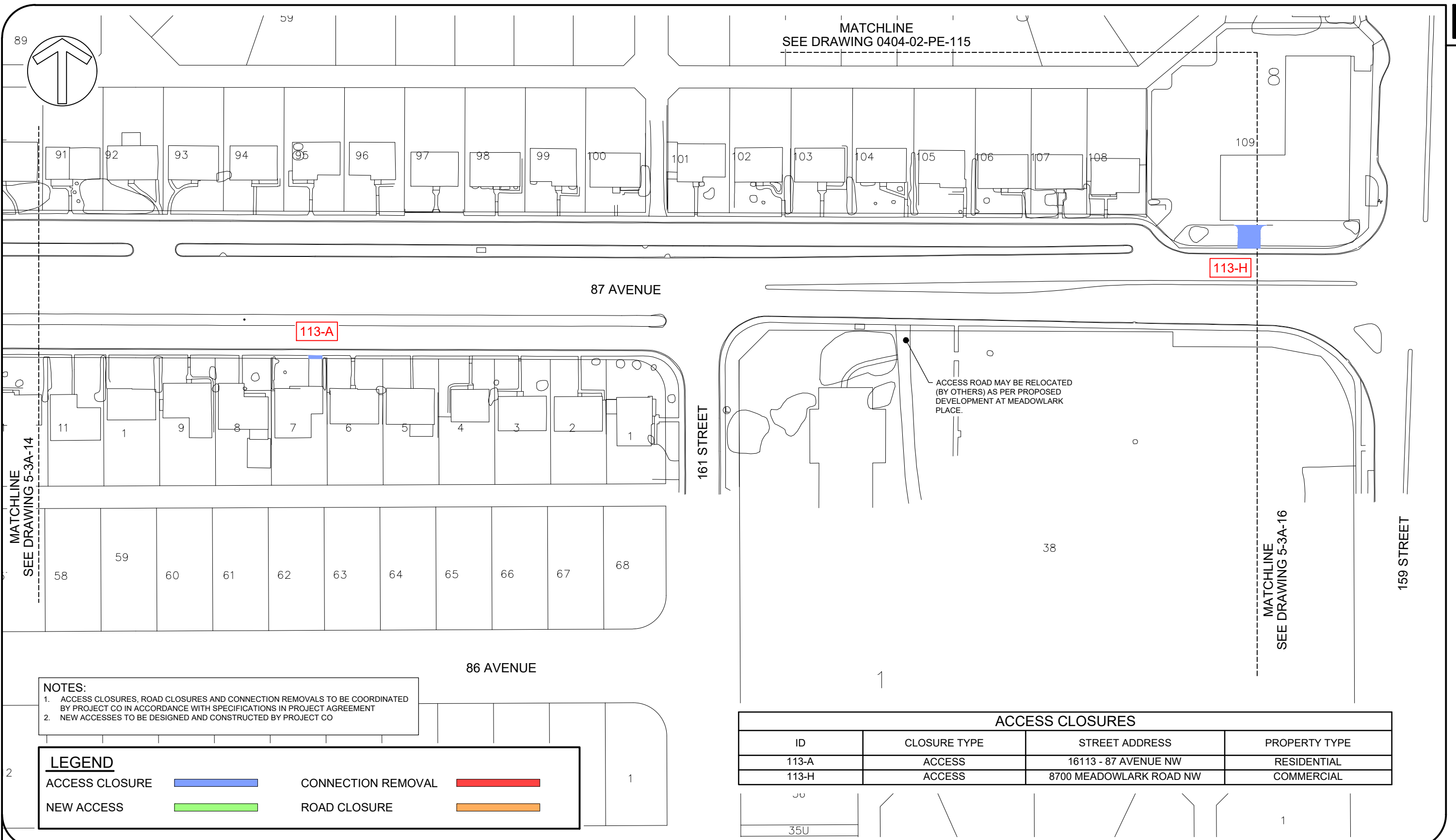

NOTES:
 1. ACCESS CLOSURES, ROAD CLOSURES AND CONNECTION REMOVALS TO BE COORDINATED BY PROJECT CO IN ACCORDANCE WITH SPECIFICATIONS IN PROJECT AGREEMENT
 2. NEW ACCESSSES TO BE DESIGNED AND CONSTRUCTED BY PROJECT CO

LEGEND			
ACCESS CLOSURE		CONNECTION REMOVAL	
NEW ACCESS		ROAD CLOSURE	

ACCESS CLOSURES			
ID	CLOSURE TYPE	STREET ADDRESS	PROPERTY TYPE
113-A	ACCESS	16113 - 87 AVENUE NW	RESIDENTIAL
113-H	ACCESS	8700 MEADOWLARK ROAD NW	COMMERCIAL

no.	description	date	checked
2	RFP V4	18-09-20	JM
1	RFP V3	07-23-20	JM
0	RFP	02-21-20	JM
	revisions		

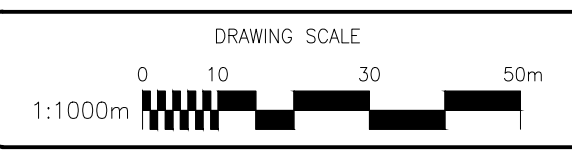

NOT FOR CONSTRUCTION

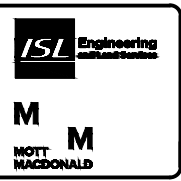

ACCESS, ALLEY & ROAD CLOSURES

DRAWING NO: 5-3A-15

AA\AMND\September 8, 2020\1\EDM\FILES\GLOBAL\PROJECTS\140001480014854_VALLEY_LINE_LRT_WEST_DESIGN_OE\02_CADD\3D_DRAFTING\2300_ROADWAY\9\06_STAGE 2 ACCESS & ROAD CLOSURES\5-3A-16.DWG

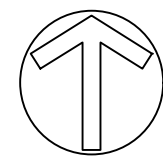
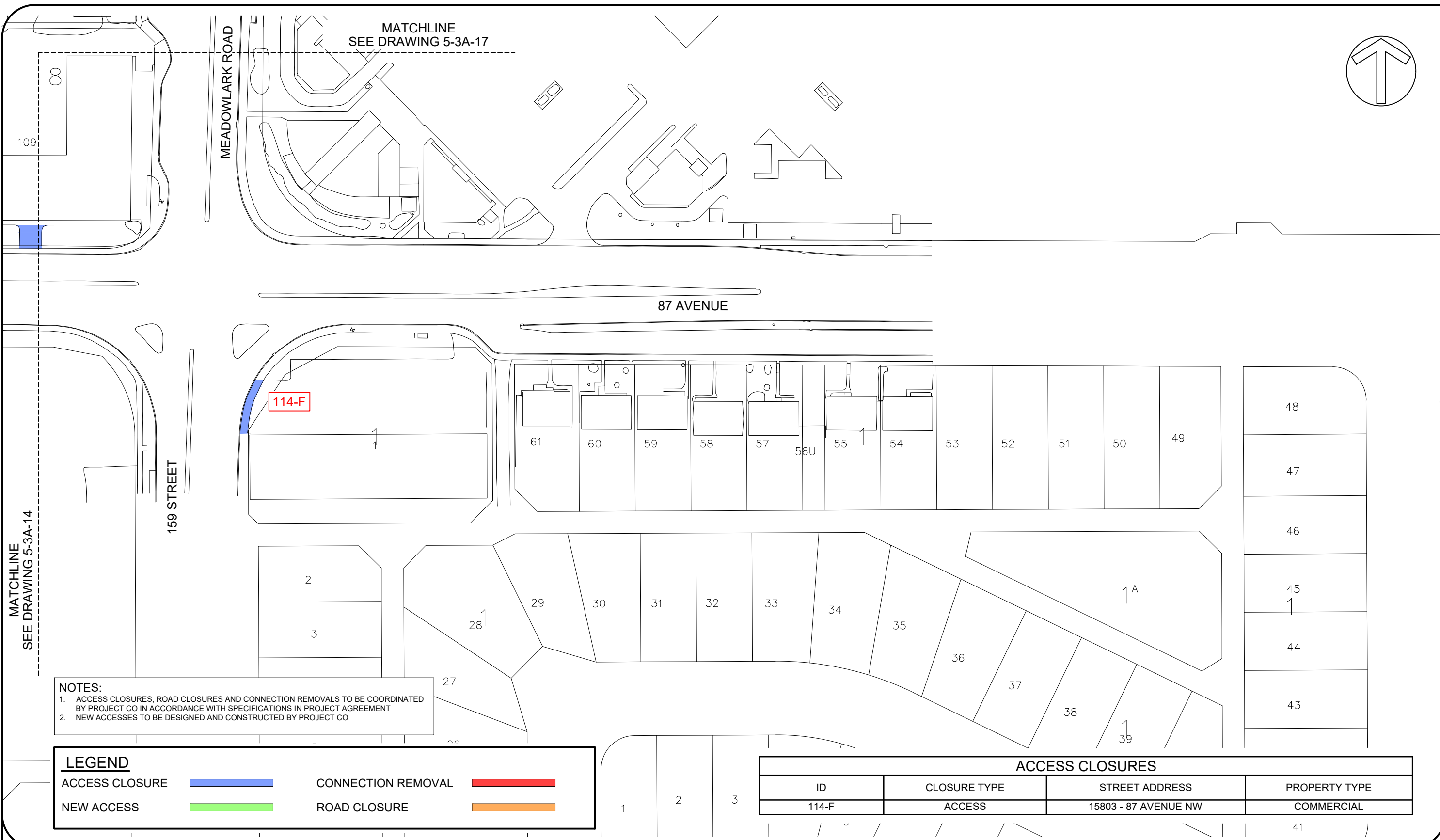

NOTES:
 1. ACCESS CLOSURES, ROAD CLOSURES AND CONNECTION REMOVALS TO BE COORDINATED BY PROJECT CO IN ACCORDANCE WITH SPECIFICATIONS IN PROJECT AGREEMENT
 2. NEW ACCESSSES TO BE DESIGNED AND CONSTRUCTED BY PROJECT CO

LEGEND			
ACCESS CLOSURE		CONNECTION REMOVAL	
NEW ACCESS		ROAD CLOSURE	

ACCESS CLOSURES			
ID	CLOSURE TYPE	STREET ADDRESS	PROPERTY TYPE
114-F	ACCESS	15803 - 87 AVENUE NW	COMMERCIAL

no.	description	date	checked
2	RFP V4	18-09-20	JM
1	RFP V3	07-23-20	JM
0	RFP	02-21-20	JM
revisions			

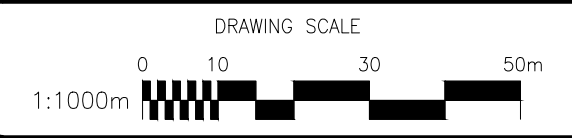

NOT FOR CONSTRUCTION

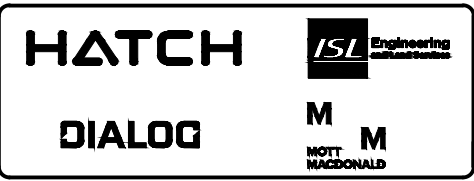

ACCESS, ALLEY & ROAD CLOSURES

DRAWING NO: 5-3A-16

VALLEY LINE WEST LRT

A:\ANAND\September 8, 2020\1\EDMONTON\GLOBALPROJECTS\140001480014854_VALLEY_LINE_LRT_WEST_DESIGN_OE\02_CADD\00_DRAFTING\2300_ROADWAY\06_STAGE 2 ACCESS & ROAD CLOSURES\5-3A-17.DWG

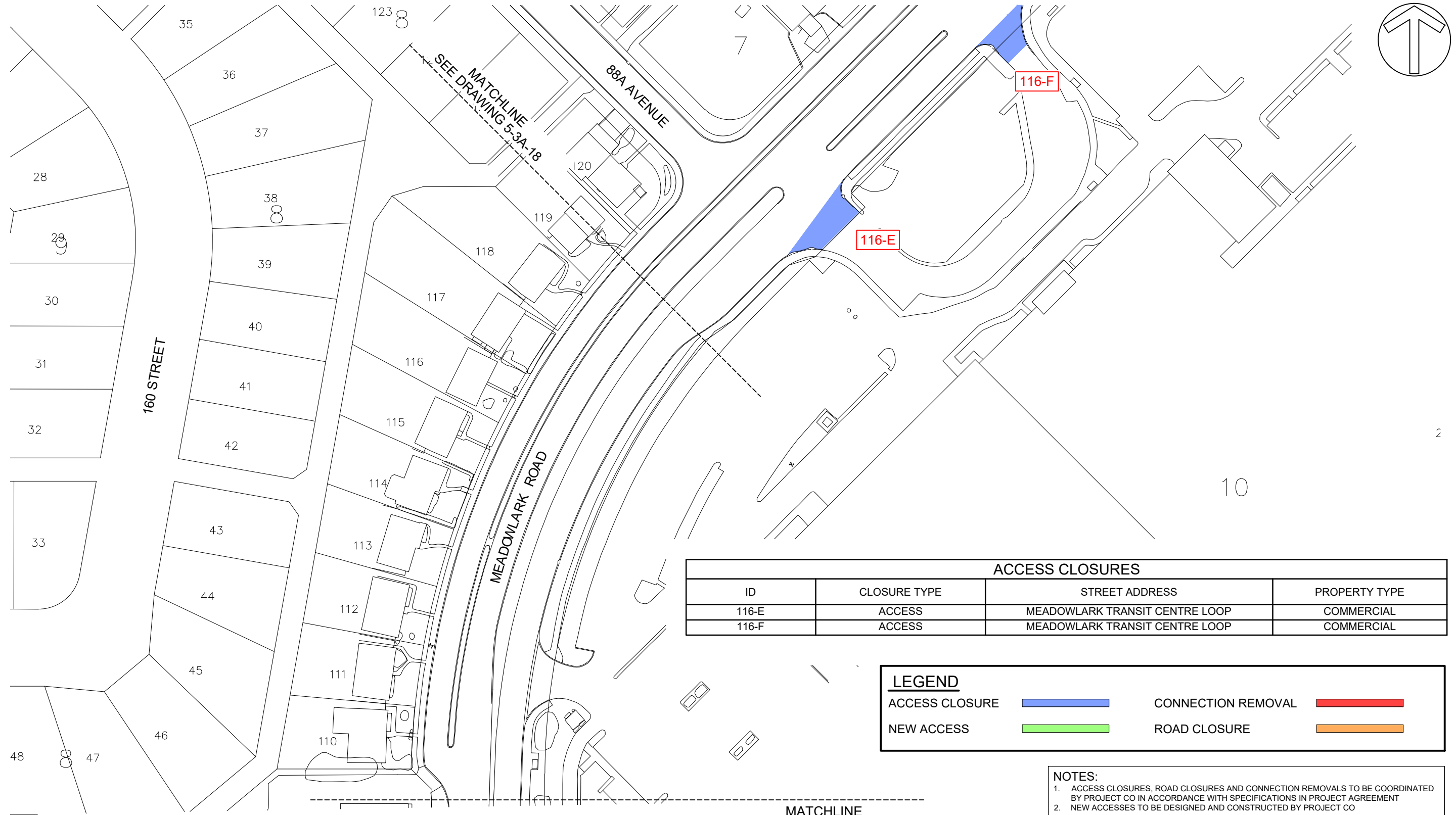

ACCESS CLOSURES			
ID	CLOSURE TYPE	STREET ADDRESS	PROPERTY TYPE
116-E	ACCESS	MEADOWLARK TRANSIT CENTRE LOOP	COMMERCIAL
116-F	ACCESS	MEADOWLARK TRANSIT CENTRE LOOP	COMMERCIAL

LEGEND

ACCESS CLOSURE		CONNECTION REMOVAL	
NEW ACCESS		ROAD CLOSURE	

NOTES:

- ACCESS CLOSURES, ROAD CLOSURES AND CONNECTION REMOVALS TO BE COORDINATED BY PROJECT CO IN ACCORDANCE WITH SPECIFICATIONS IN PROJECT AGREEMENT
- NEW ACCESSES TO BE DESIGNED AND CONSTRUCTED BY PROJECT CO

MATCHLINE
SEE DRAWING 5-3A-16

no.	description	date	checked
2	RFP V4	18-09-20	JM
1	RFP V3	07-23-20	JM
0	RFP	02-21-20	JM

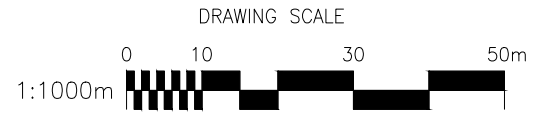

NOT FOR CONSTRUCTION

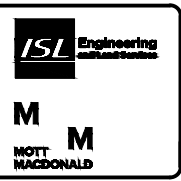

ACCESS, ALLEY & ROAD CLOSURES

DRAWING NO: 5-3A-17

VALLEY LINE WEST LRT

A:\AMAND\September 8, 2020\1\EDM\FILER\ISL\GLOBAL\PROJECTS\140001480014854_VALLEY_LINE_LRT_WEST_DESIGN_OE\02_CADD\00_DRAFTING\2300_ROADWAY\06_STAGE 2 ACCESS & ROAD CLOSURES\5-3A-18.DWG

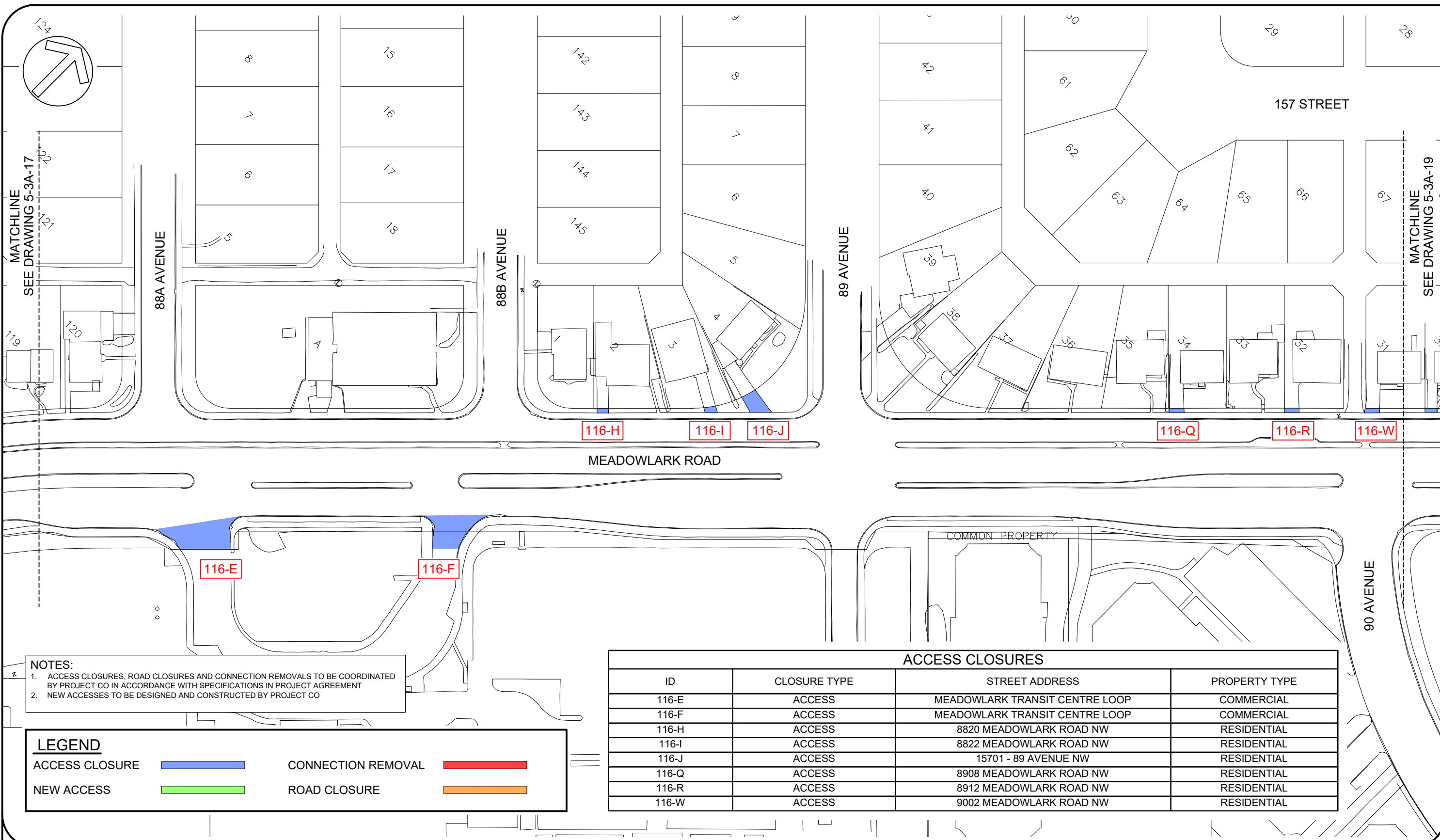

NOTES:
 1. ACCESS CLOSURES, ROAD CLOSURES AND CONNECTION REMOVALS TO BE COORDINATED BY PROJECT CO IN ACCORDANCE WITH SPECIFICATIONS IN PROJECT AGREEMENT
 2. NEW ACCESSES TO BE DESIGNED AND CONSTRUCTED BY PROJECT CO

LEGEND			
ACCESS CLOSURE		CONNECTION REMOVAL	
NEW ACCESS		ROAD CLOSURE	

ACCESS CLOSURES			
ID	CLOSURE TYPE	STREET ADDRESS	PROPERTY TYPE
116-E	ACCESS	MEADOWLARK TRANSIT CENTRE LOOP	COMMERCIAL
116-F	ACCESS	MEADOWLARK TRANSIT CENTRE LOOP	COMMERCIAL
116-H	ACCESS	8820 MEADOWLARK ROAD NW	RESIDENTIAL
116-I	ACCESS	8822 MEADOWLARK ROAD NW	RESIDENTIAL
116-J	ACCESS	15701 - 89 AVENUE NW	RESIDENTIAL
116-Q	ACCESS	8908 MEADOWLARK ROAD NW	RESIDENTIAL
116-R	ACCESS	8912 MEADOWLARK ROAD NW	RESIDENTIAL
116-W	ACCESS	9002 MEADOWLARK ROAD NW	RESIDENTIAL

no.	description	date	checked
2	RFP V4	18-09-20	JM
1	RFP V3	07-23-20	JM
0	RFP	02-21-20	JM
revisions			

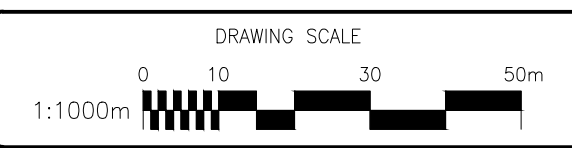

NOT FOR CONSTRUCTION



ACCESS, ALLEY & ROAD CLOSURES

DRAWING NO: 5-3A-18

VALLEY LINE WEST LRT

A:\ANAND\September 8, 2020\1\EDM\FILER\ISL\GLOBAL\PROJECTS\140001480014854_VALLEY_LINE_LRT_WEST_DESIGN_OE\02_CADD\3D_DRAFTING\2300_ROADWAY\06_STAGE 2 ACCESS & ROAD CLOSURES\5-3A-19.DWG

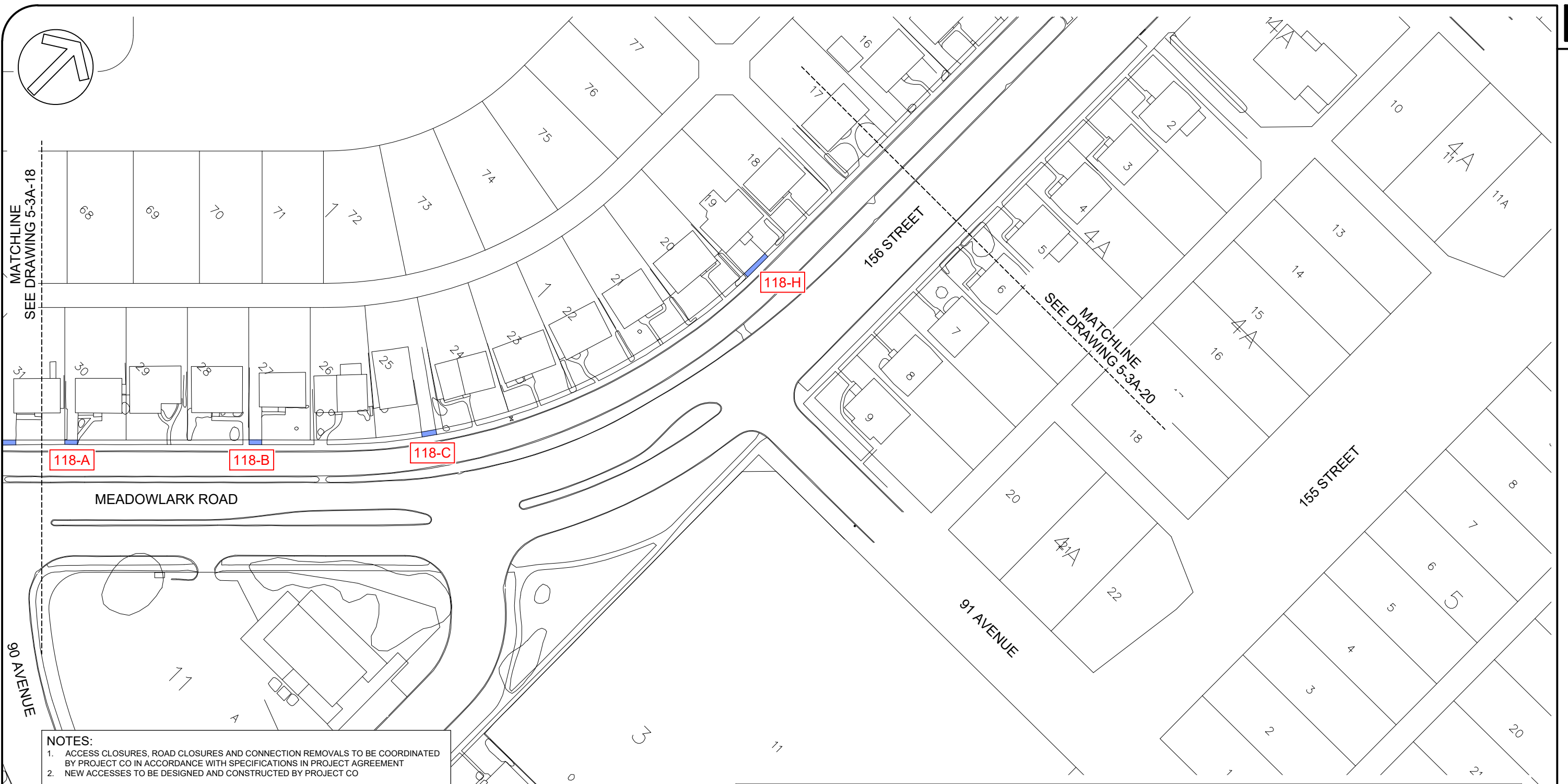

NOTES:
 1. ACCESS CLOSURES, ROAD CLOSURES AND CONNECTION REMOVALS TO BE COORDINATED BY PROJECT CO IN ACCORDANCE WITH SPECIFICATIONS IN PROJECT AGREEMENT
 2. NEW ACCESSSES TO BE DESIGNED AND CONSTRUCTED BY PROJECT CO

LEGEND

ACCESS CLOSURE		CONNECTION REMOVAL	
NEW ACCESS		ROAD CLOSURE	

ACCESS CLOSURES			
ID	CLOSURE TYPE	STREET ADDRESS	PROPERTY TYPE
118-A	ACCESS	9004 MEADOWLARK ROAD NW	RESIDENTIAL
118-B	ACCESS	9010 MEADOWLARK ROAD NW	RESIDENTIAL
118-C	ACCESS	9014 MEADOWLARK ROAD NW	RESIDENTIAL
118-H	ACCESS	9106 - 156 STREET	RESIDENTIAL

no.	description	date	checked
3	RFP V4	18-09-20	JM
2	RFP V3	07-23-20	JM
1	RFP V2	29-05-20	JM
0	RFP	02-21-20	JM

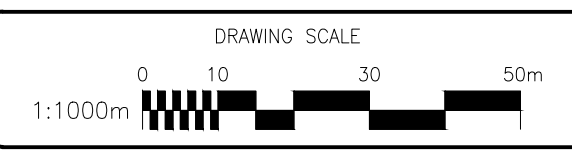

NOT FOR CONSTRUCTION

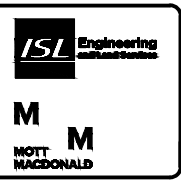

ACCESS, ALLEY & ROAD CLOSURES

DRAWING NO: 5-3A-19

VALLEY LINE WEST LRT

AAAMND / September 8, 2020 / I:\EDM\FILERS\GLOBAL\PROJECTS\140001480014854_VALLEY_LINE_LRT_WEST_DESIGN_OE\02_CADD\00_DRAFTING\2300_ROADWAY\06_STAGE 2 ACCESS & ROAD CLOSURES\5-3A-20.DWG

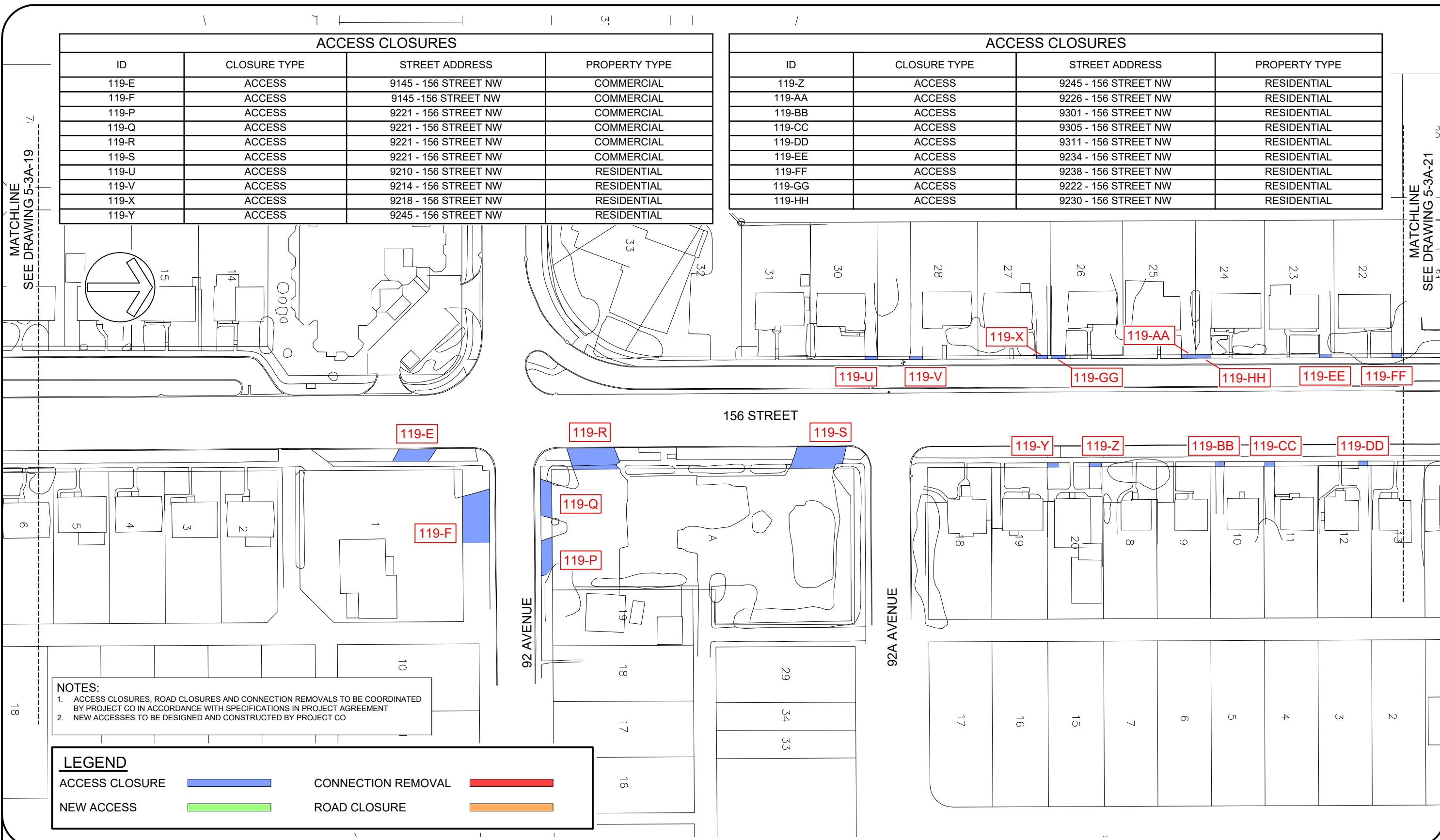

ACCESS CLOSURES			
ID	CLOSURE TYPE	STREET ADDRESS	PROPERTY TYPE
119-E	ACCESS	9145 - 156 STREET NW	COMMERCIAL
119-F	ACCESS	9145 - 156 STREET NW	COMMERCIAL
119-P	ACCESS	9221 - 156 STREET NW	COMMERCIAL
119-Q	ACCESS	9221 - 156 STREET NW	COMMERCIAL
119-R	ACCESS	9221 - 156 STREET NW	COMMERCIAL
119-S	ACCESS	9221 - 156 STREET NW	COMMERCIAL
119-U	ACCESS	9210 - 156 STREET NW	RESIDENTIAL
119-V	ACCESS	9214 - 156 STREET NW	RESIDENTIAL
119-X	ACCESS	9218 - 156 STREET NW	RESIDENTIAL
119-Y	ACCESS	9245 - 156 STREET NW	RESIDENTIAL

ACCESS CLOSURES			
ID	CLOSURE TYPE	STREET ADDRESS	PROPERTY TYPE
119-Z	ACCESS	9245 - 156 STREET NW	RESIDENTIAL
119-AA	ACCESS	9226 - 156 STREET NW	RESIDENTIAL
119-BB	ACCESS	9301 - 156 STREET NW	RESIDENTIAL
119-CC	ACCESS	9305 - 156 STREET NW	RESIDENTIAL
119-DD	ACCESS	9311 - 156 STREET NW	RESIDENTIAL
119-EE	ACCESS	9234 - 156 STREET NW	RESIDENTIAL
119-FF	ACCESS	9238 - 156 STREET NW	RESIDENTIAL
119-GG	ACCESS	9222 - 156 STREET NW	RESIDENTIAL
119-HH	ACCESS	9230 - 156 STREET NW	RESIDENTIAL

NOTES:
 1. ACCESS CLOSURES, ROAD CLOSURES AND CONNECTION REMOVALS TO BE COORDINATED BY PROJECT CO IN ACCORDANCE WITH SPECIFICATIONS IN PROJECT AGREEMENT
 2. NEW ACCESSSES TO BE DESIGNED AND CONSTRUCTED BY PROJECT CO

LEGEND			
ACCESS CLOSURE		CONNECTION REMOVAL	
NEW ACCESS		ROAD CLOSURE	

MATCHLINE
SEE DRAWING 5-3A-19

MATCHLINE
SEE DRAWING 5-3A-21

VALLEY LINE WEST LRT

no.	description	date	checked
2	RFP V4	18-09-20	JM
1	RFP V3	07-23-20	JM
0	RFP	02-21-20	JM
	revisions		

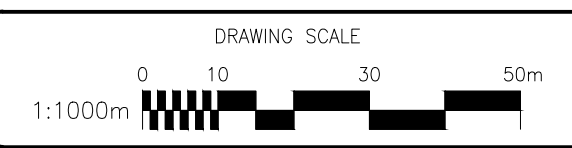

NOT FOR CONSTRUCTION



ACCESS, ALLEY & ROAD CLOSURES

DRAWING NO: 5-3A-20

AAAMND / September 8, 2020 / I:\EDM\FILERS\GLOBAL\PROJECTS\140001480014854_VALLEY_LINE_LRT_WEST_DESIGN_OE\02_CADD\00_DRAFTING\2300_ROADWAY\06_STAGE 2 ACCESS & ROAD CLOSURES\5-3A-21.DWG

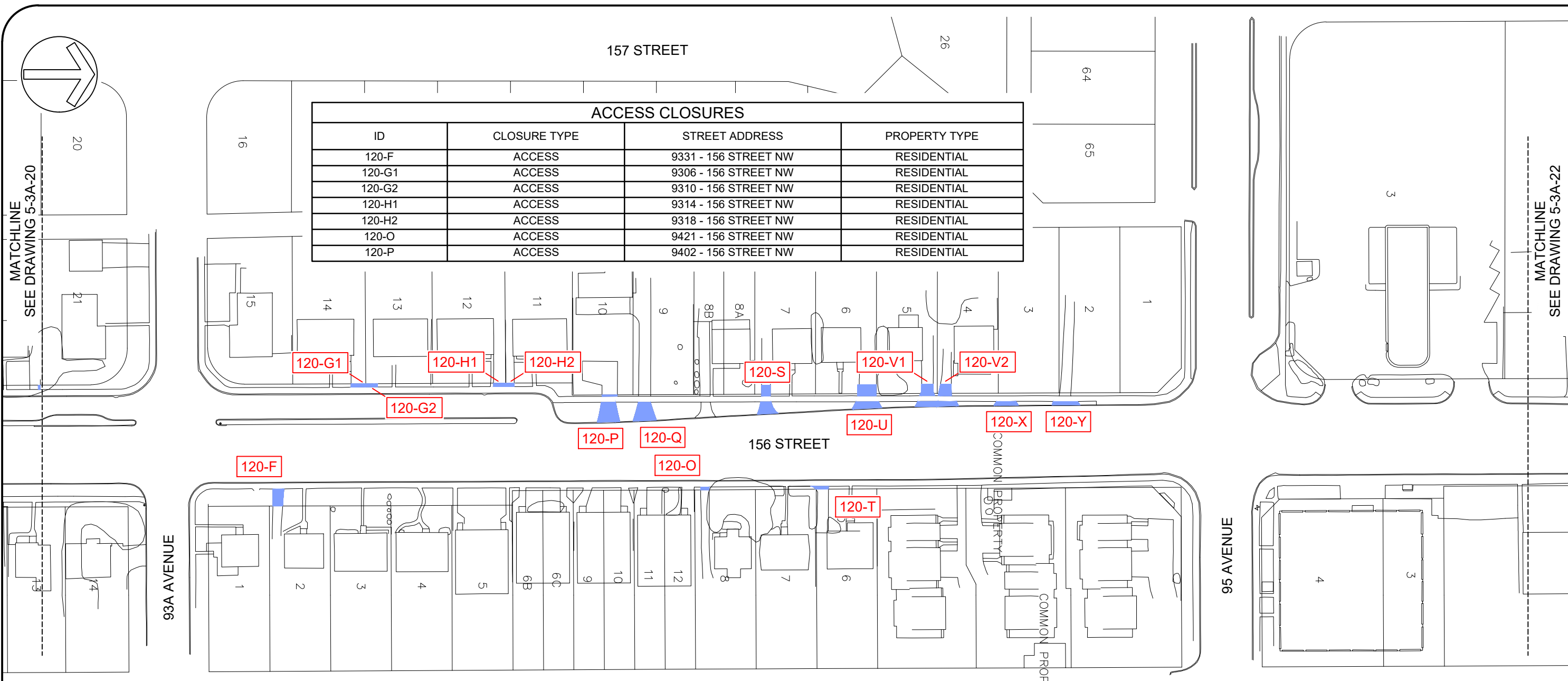

ACCESS CLOSURES			
ID	CLOSURE TYPE	STREET ADDRESS	PROPERTY TYPE
120-F	ACCESS	9331 - 156 STREET NW	RESIDENTIAL
120-G1	ACCESS	9306 - 156 STREET NW	RESIDENTIAL
120-G2	ACCESS	9310 - 156 STREET NW	RESIDENTIAL
120-H1	ACCESS	9314 - 156 STREET NW	RESIDENTIAL
120-H2	ACCESS	9318 - 156 STREET NW	RESIDENTIAL
120-O	ACCESS	9421 - 156 STREET NW	RESIDENTIAL
120-P	ACCESS	9402 - 156 STREET NW	RESIDENTIAL

ACCESS CLOSURES			
ID	CLOSURE TYPE	STREET ADDRESS	PROPERTY TYPE
120-Q	ACCESS	9406 - 156 STREET NW	RESIDENTIAL
120-S	ACCESS	9416 - 156 STREET NW	RESIDENTIAL
120-T	ACCESS	9429 - 156 STREET NW	RESIDENTIAL
120-U	ACCESS	9422 - 156 STREET NW	RESIDENTIAL
120-V1	ACCESS	9426 - 156 STREET NW	RESIDENTIAL
120-V2	ACCESS	9432 - 156 STREET NW	RESIDENTIAL
120-X	ACCESS	9438 - 156 STREET NW	RESIDENTIAL
120-Y	ACCESS	9444 - 156 STREET NW	RESIDENTIAL

NOTES:
 1. ACCESS CLOSURES, ROAD CLOSURES AND CONNECTION REMOVALS TO BE COORDINATED BY PROJECT CO IN ACCORDANCE WITH SPECIFICATIONS IN PROJECT AGREEMENT
 2. NEW ACCESSSES TO BE DESIGNED AND CONSTRUCTED BY PROJECT CO

LEGEND

ACCESS CLOSURE		CONNECTION REMOVAL	
NEW ACCESS		ROAD CLOSURE	

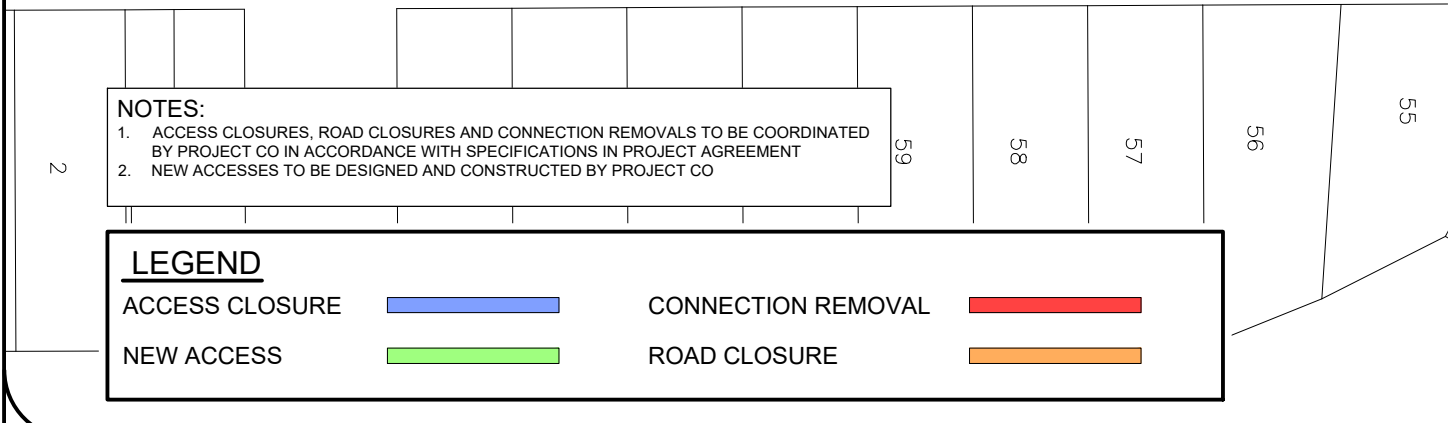

no.	description	date	checked
2	RFP V4	18-09-20	JM
1	RFP V3	07-23-20	JM
0	RFP	02-21-20	JM
revisions			

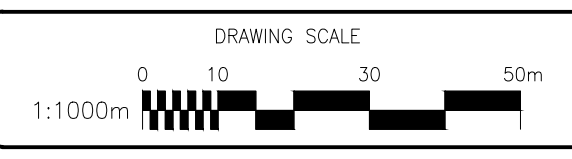

NOT FOR CONSTRUCTION

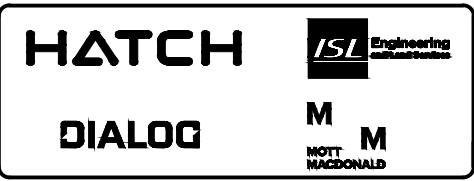

ACCESS, ALLEY & ROAD CLOSURES

DRAWING NO: 5-3A-21

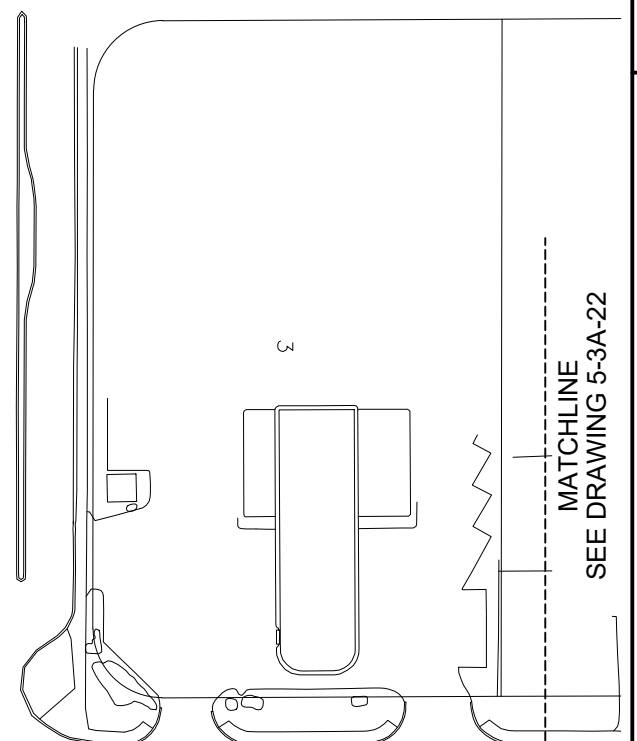
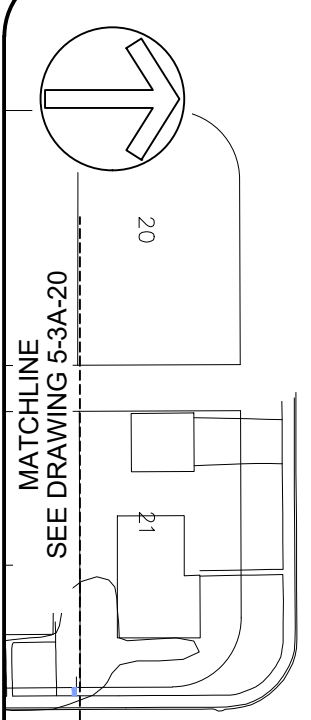

VALLEY LINE WEST LRT

A:\AAND\September 8, 2020\AEDM\FILER\ISL\GLOBAL\PROJECTS\140001480014854_VALLEY_LINE_LRT_WEST_DESIGN_OE\02_CADD\00_DRAFTING\2300_ROADWAY\06_STAGE 2 ACCESS & ROAD CLOSURES\5-3A-22.DWG



NOTES:
 1. ACCESS CLOSURES, ROAD CLOSURES AND CONNECTION REMOVALS TO BE COORDINATED BY PROJECT CO IN ACCORDANCE WITH SPECIFICATIONS IN PROJECT AGREEMENT
 2. NEW ACCESSSES TO BE DESIGNED AND CONSTRUCTED BY PROJECT CO

LEGEND

ACCESS CLOSURE		CONNECTION REMOVAL	
NEW ACCESS		ROAD CLOSURE	

no.	description	date	checked
2	RFP V4	18-09-20	JM
1	RFP V3	07-23-20	JM
0	RFP	02-21-20	JM
revisions			

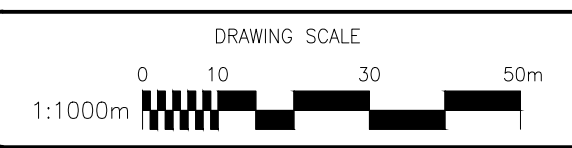

NOT FOR CONSTRUCTION

AECOM
Prime Consultant

Edmonton

HATCH

DIALOG

ISL Engineering

MOTT MACDONALD

ACCESS, ALLEY & ROAD CLOSURES

DRAWING NO: 5-3A-22

VALLEY LINE WEST LRT

AA\AMND\September 8, 2020\1\ED\FILES\ISL\GLOBAL\PROJECTS\140001480014854_VALLEY_LINE_LRT_WEST_DESIGN_OE\02_CADD\00_DRAFTING\2300_ROADWAY\06_STAGE 2 ACCESS & ROAD CLOSURES\5-3A-23.DWG

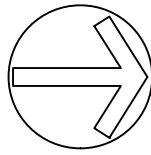

MATCHLINE
SEE DRAWING 5-3A-22

MATCHLINE
SEE DRAWING 5-3A-24

ACCESS CLOSURES			
ID	CLOSURE TYPE	STREET ADDRESS	PROPERTY TYPE
122-L	ACCESS	9849 - 156 STREET NW	COMMERCIAL
122-N	ACCESS	9920 - 156 STREET NW	RESIDENTIAL
122-O	ACCESS	9928 - 156 STREET NW	RESIDENTIAL

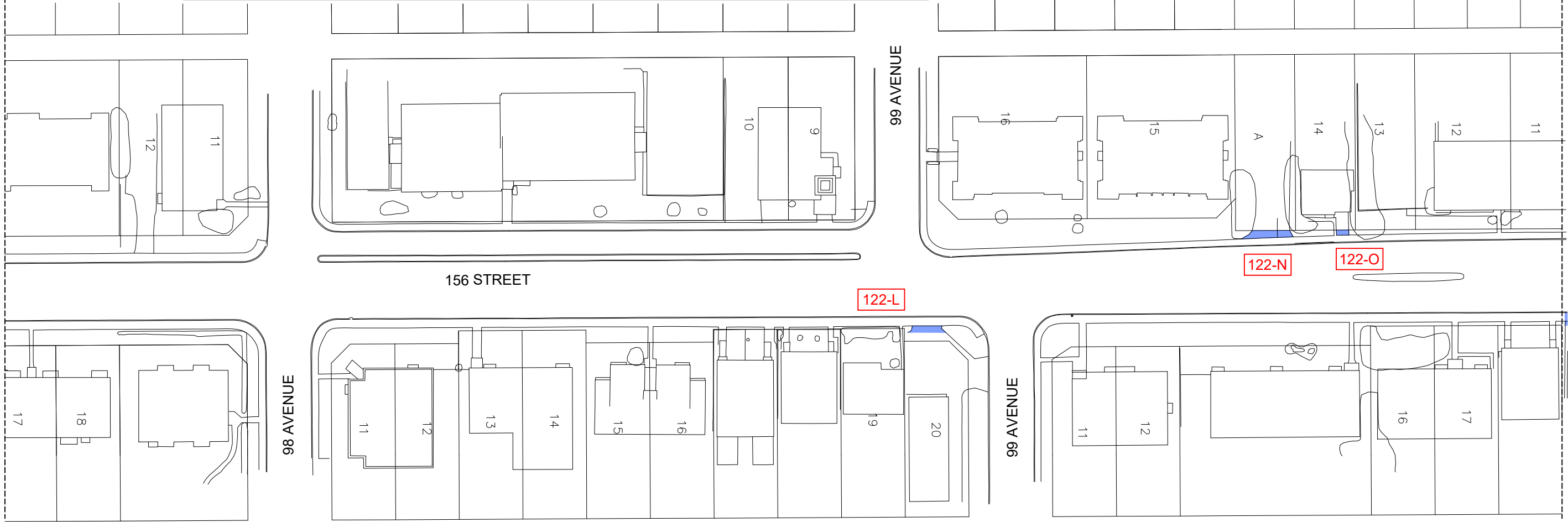

NOTES:

- ACCESS CLOSURES, ROAD CLOSURES AND CONNECTION REMOVALS TO BE COORDINATED BY PROJECT CO IN ACCORDANCE WITH SPECIFICATIONS IN PROJECT AGREEMENT
- NEW ACCESSSES TO BE DESIGNED AND CONSTRUCTED BY PROJECT CO

LEGEND

- | | | | |
|----------------|--|--------------------|--|
| ACCESS CLOSURE | | CONNECTION REMOVAL | |
| NEW ACCESS | | ROAD CLOSURE | |

no.	description	date	checked
2	RFP V4	18-09-20	JM
1	RFP V3	07-23-20	JM
0	RFP	02-21-20	JM
revisions			

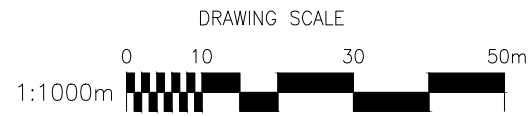

**NOT FOR
CONSTRUCTION**



ACCESS, ALLEY & ROAD CLOSURES

DRAWING NO: 5-3A-23

VALLEY LINE WEST LRT

AA\AMND\September 8, 2020\1\EDM\FILES\GLOBAL\PROJECTS\140001480014854_VALLEY_LINE_LRT_WEST_DESIGN_OE\02_CADD\00_DRAFTING\2300_ROADWAY\06_STAGE 2 ACCESS & ROAD CLOSURES\5-3A-24.DWG

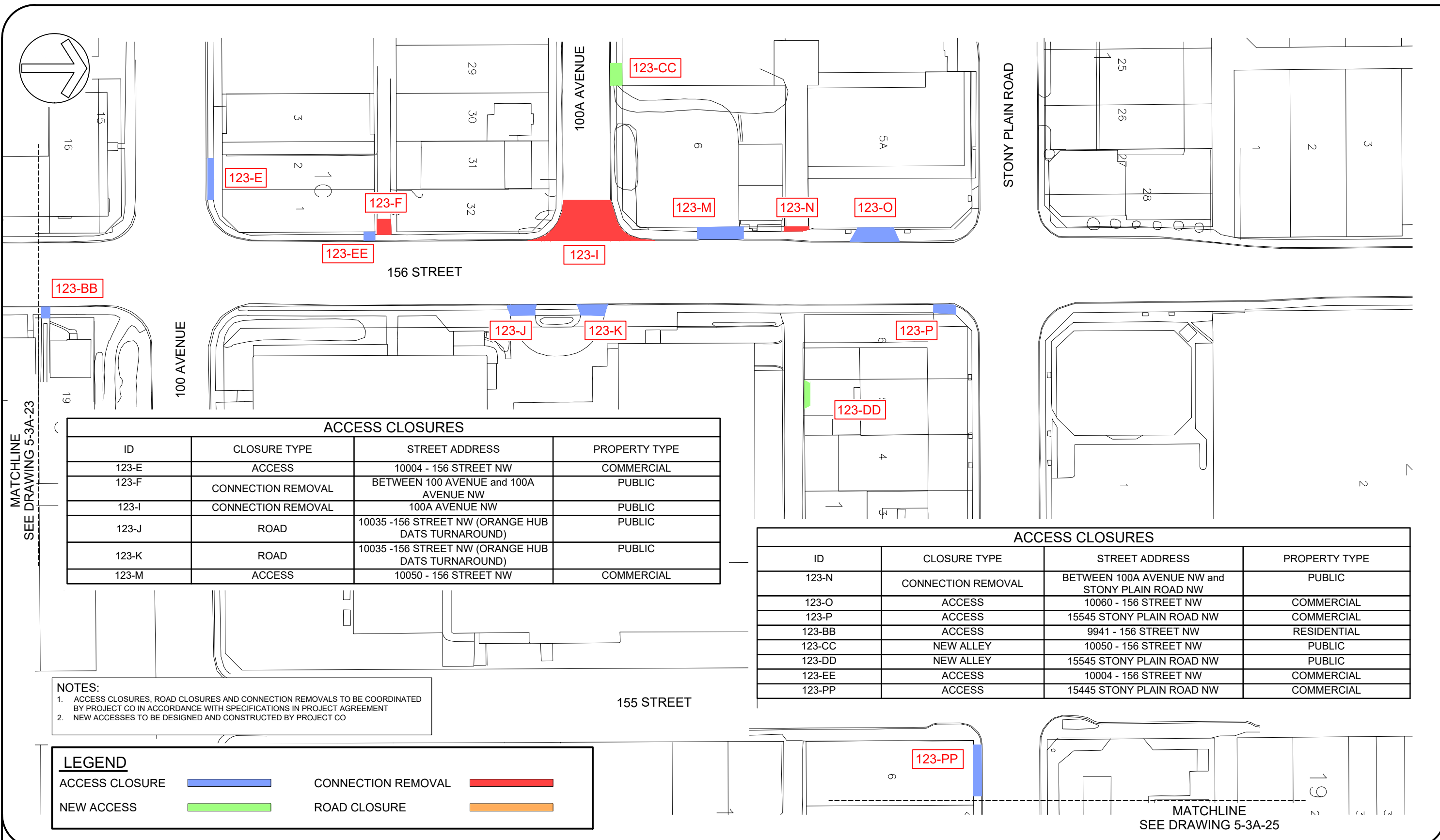

ACCESS CLOSURES			
ID	CLOSURE TYPE	STREET ADDRESS	PROPERTY TYPE
123-E	ACCESS	10004 - 156 STREET NW	COMMERCIAL
123-F	CONNECTION REMOVAL	BETWEEN 100 AVENUE and 100A AVENUE NW	PUBLIC
123-I	CONNECTION REMOVAL	100A AVENUE NW	PUBLIC
123-J	ROAD	10035 -156 STREET NW (ORANGE HUB DATS TURNAROUND)	PUBLIC
123-K	ROAD	10035 -156 STREET NW (ORANGE HUB DATS TURNAROUND)	PUBLIC
123-M	ACCESS	10050 - 156 STREET NW	COMMERCIAL

ACCESS CLOSURES			
ID	CLOSURE TYPE	STREET ADDRESS	PROPERTY TYPE
123-N	CONNECTION REMOVAL	BETWEEN 100A AVENUE NW and STONY PLAIN ROAD NW	PUBLIC
123-O	ACCESS	10060 - 156 STREET NW	COMMERCIAL
123-P	ACCESS	15545 STONY PLAIN ROAD NW	COMMERCIAL
123-BB	ACCESS	9941 - 156 STREET NW	RESIDENTIAL
123-CC	NEW ALLEY	10050 - 156 STREET NW	PUBLIC
123-DD	NEW ALLEY	15545 STONY PLAIN ROAD NW	PUBLIC
123-EE	ACCESS	10004 - 156 STREET NW	COMMERCIAL
123-PP	ACCESS	15445 STONY PLAIN ROAD NW	COMMERCIAL

NOTES:
 1. ACCESS CLOSURES, ROAD CLOSURES AND CONNECTION REMOVALS TO BE COORDINATED BY PROJECT CO IN ACCORDANCE WITH SPECIFICATIONS IN PROJECT AGREEMENT
 2. NEW ACCESSSES TO BE DESIGNED AND CONSTRUCTED BY PROJECT CO

LEGEND

ACCESS CLOSURE		CONNECTION REMOVAL	
NEW ACCESS		ROAD CLOSURE	

no.	description	date	checked
2	RFP V4	18-09-20	JM
1	RFP V3	07-23-20	JM
0	RFP	02-21-20	JM
	revisions		

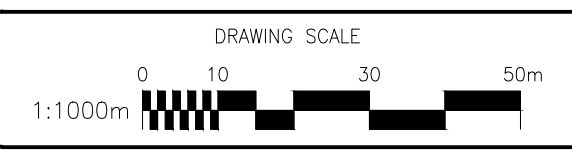

NOT FOR CONSTRUCTION

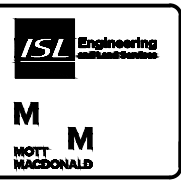

ACCESS, ALLEY & ROAD CLOSURES

DRAWING NO: 5-3A-24

VALLEY LINE WEST LRT

A:\AMAND \September 8, 2020\1\EDM\FILER\ISL\GLOBAL\PROJECTS\140001\48001\4854_VALLEY_LINE_LRT_WEST_DESIGN_OE\02_CADD\30_DRAFTING\2300_ROADWAY\9\06_STAGE 2 ACCESS & ROAD CLOSURES\5-3A-25.DWG



NOTES:
 1. ACCESS CLOSURES, ROAD CLOSURES AND CONNECTION REMOVALS TO BE COORDINATED BY PROJECT CO IN ACCORDANCE WITH SPECIFICATIONS IN PROJECT AGREEMENT
 2. NEW ACCESSSES TO BE DESIGNED AND CONSTRUCTED BY PROJECT CO

LEGEND			
ACCESS CLOSURE		CONNECTION REMOVAL	
NEW ACCESS		ROAD CLOSURE	

no.	description	date	checked
2	RFP V4	18-09-20	JM
1	RFP V3	07-23-20	JM
0	RFP	02-21-20	JM
revisions			

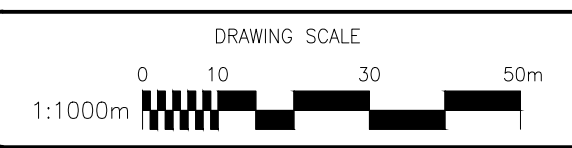

NOT FOR CONSTRUCTION

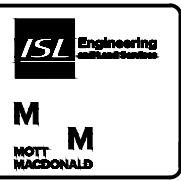

ACCESS, ALLEY & ROAD CLOSURES

DRAWING NO: 5-3A-25

VALLEY LINE WEST LRT

A:\AMAND / September 8, 2020 / MEDFILER\ISL\GLOBAL\PROJECTS\140001480014854_VALLEY_LINE_LRT_WEST_DESIGN_OE\02_CADD\00_DRAFTING\2300_ROADWAY\06_STAGE 2 ACCESS & ROAD CLOSURES\5-3A-26.DWG

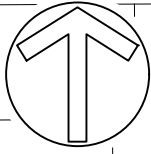

MATCHLINE
SEE DRAWING 5-3A-25

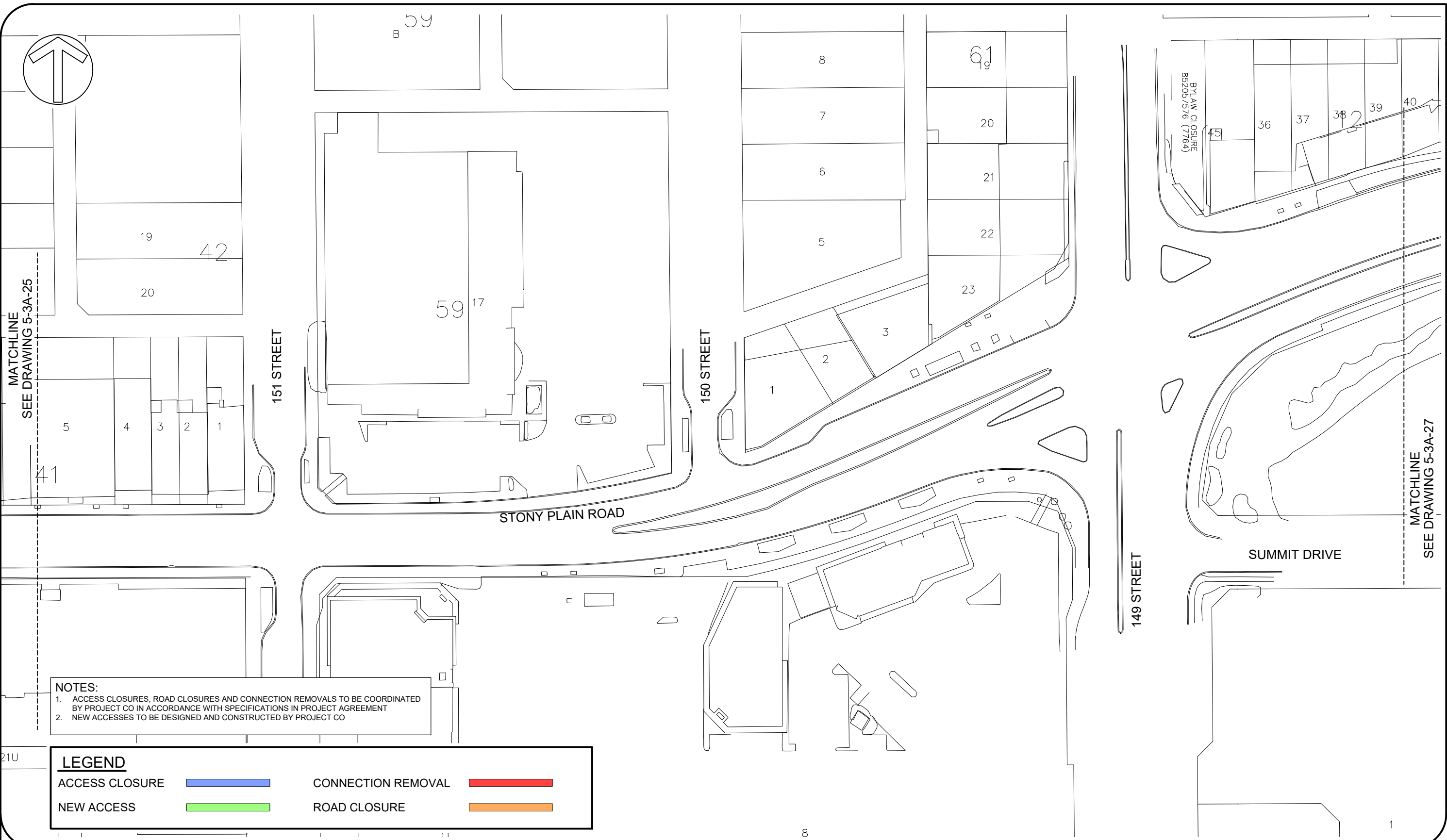

NOTES:

1. ACCESS CLOSURES, ROAD CLOSURES AND CONNECTION REMOVALS TO BE COORDINATED BY PROJECT CO IN ACCORDANCE WITH SPECIFICATIONS IN PROJECT AGREEMENT
2. NEW ACCESSSES TO BE DESIGNED AND CONSTRUCTED BY PROJECT CO

LEGEND

- | | | | |
|----------------|--|--------------------|--|
| ACCESS CLOSURE | | CONNECTION REMOVAL | |
| NEW ACCESS | | ROAD CLOSURE | |

no.	description	date	checked
2	RFP V4	18-09-20	JM
1	RFP V3	07-23-20	JM
0	RFP	02-21-20	JM
revisions			

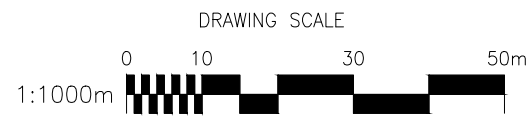

**NOT FOR
CONSTRUCTION**



ACCESS, ALLEY & ROAD CLOSURES

DRAWING NO: 5-3A-26

VALLEY LINE WEST LRT

AAAMND / September 8, 2020 / I:\EDM\FILERS\GLOBAL\PROJECTS\140001480014854_VALLEY_LINE_LRT_WEST_DESIGN_OE\02_CADD\00_DRAFTING\2300_ROADWAY\06_STAGE 2 ACCESS & ROAD CLOSURES\5-3A-27.DWG

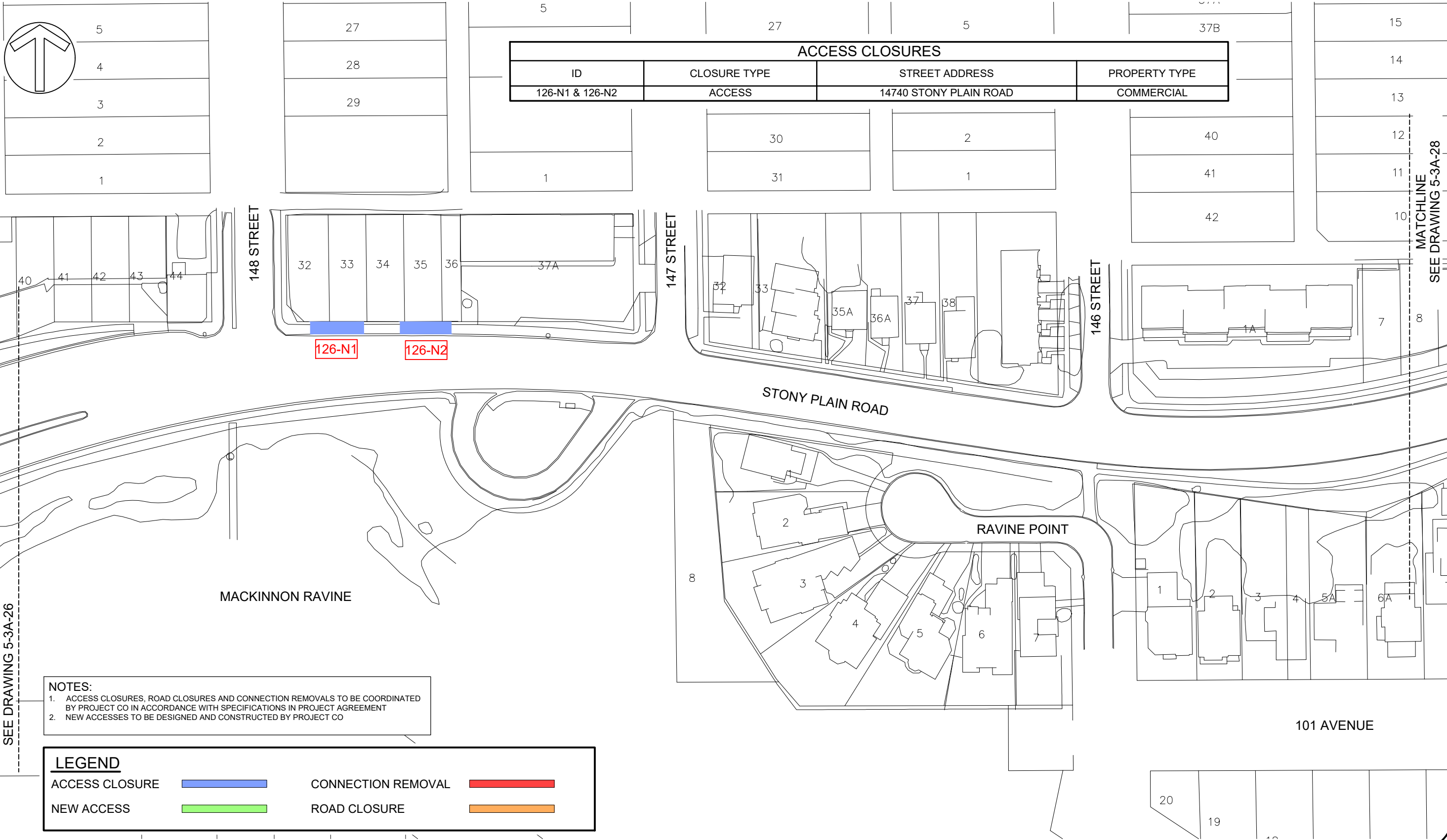

MATCHLINE
SEE DRAWING 5-3A-26

MATCHLINE
SEE DRAWING 5-3A-28

VALLEY LINE WEST LRT

NOTES:
 1. ACCESS CLOSURES, ROAD CLOSURES AND CONNECTION REMOVALS TO BE COORDINATED BY PROJECT CO IN ACCORDANCE WITH SPECIFICATIONS IN PROJECT AGREEMENT
 2. NEW ACCESSES TO BE DESIGNED AND CONSTRUCTED BY PROJECT CO

LEGEND			
ACCESS CLOSURE		CONNECTION REMOVAL	
NEW ACCESS		ROAD CLOSURE	

no.	description	date	checked
3	RFP V4	18-09-20	JM
2	RFP V3	07-23-20	JM
1	RFP V2	29-05-20	JM
0	RFP	02-21-20	JM
revisions			

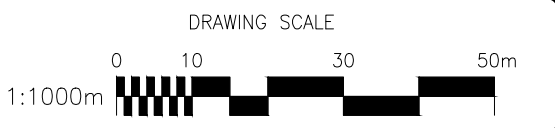

NOT FOR CONSTRUCTION



ISL Engineering

MOTT MACDONALD

ACCESS, ALLEY & ROAD CLOSURES

DRAWING NO: 5-3A-27

TKL005 / September 8, 2020 / G:\PROJECTS\14000\14801\4854_VALLEY_LINE_LRT_WEST_DESIGN_CEO\2 CAD\200_DRAFTING\2300_ROADWAYS\06_STAGE 2 ACCESS & ROAD CLOSURES\5-3A-28.DWG



NOTES:
 1. ACCESS CLOSURES, ROAD CLOSURES AND CONNECTION REMOVALS TO BE COORDINATED BY PROJECT CO IN ACCORDANCE WITH SPECIFICATIONS IN PROJECT AGREEMENT
 2. NEW ACCESSSES TO BE DESIGNED AND CONSTRUCTED BY PROJECT CO

LEGEND			
ACCESS CLOSURE		CONNECTION REMOVAL	
NEW ACCESS		ROAD CLOSURE	

ACCESS CLOSURES			
ID	CLOSURE TYPE	STREET ADDRESS	PROPERTY TYPE
127-H	ACCESS	14409 STONY PLAIN ROAD NW	RESIDENTIAL
127-P	ROAD	143 STREET NW	PUBLIC
127-R	ACCESS	14224 STONY PLAIN ROAD NW	COMMERCIAL

no.	description	date	checked
2	RFP V4	18-09-20	JM
1	RFP V3	07-23-20	JM
0	RFP	02-21-20	JM
revisions			

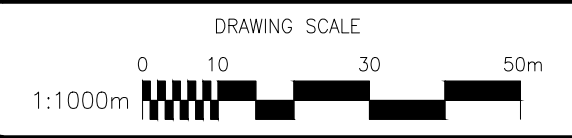

NOT FOR CONSTRUCTION



ACCESS, ALLEY & ROAD CLOSURES

DRAWING NO: 5-3A-28

VALLEY LINE WEST LRT

A:\ANAND\September 8, 2020\1\EDM\FILER\ISL\GLOBAL\PROJECTS\140001480014854_VALLEY_LINE_LRT_WEST_DESIGN_OE\02_CADD\00_DRAFTING\2300_ROADWAY\06_STAGE 2 ACCESS & ROAD CLOSURES\5-3A-29.DWG

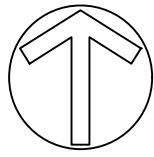

MATCHLINE
SEE DRAWING 5-3A-28

MATCHLINE
SEE DRAWING 0404-02-PE-129

VALLEY LINE WEST LRT

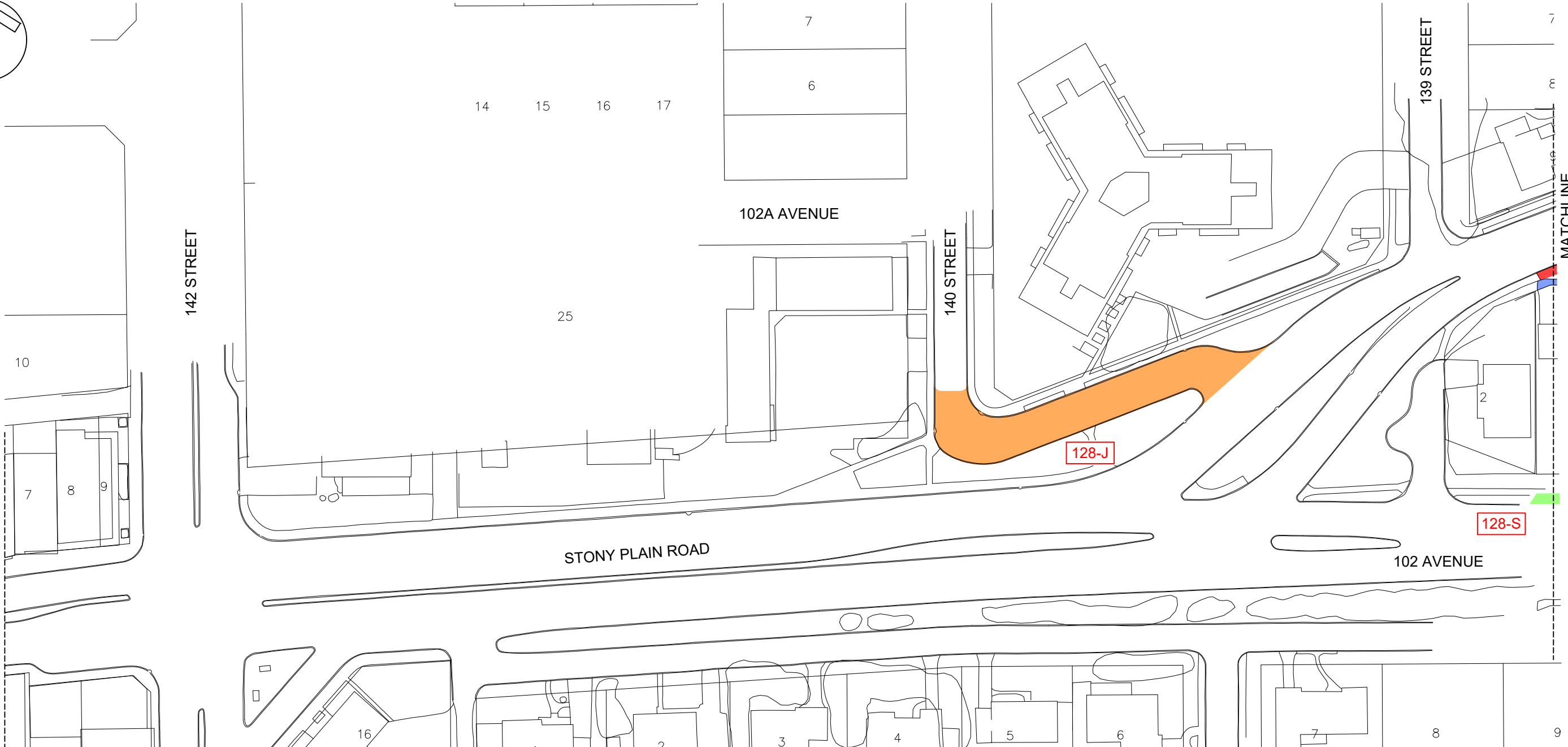

NOTES:
 1. ACCESS CLOSURES, ROAD CLOSURES AND CONNECTION REMOVALS TO BE COORDINATED BY PROJECT CO IN ACCORDANCE WITH SPECIFICATIONS IN PROJECT AGREEMENT
 2. NEW ACCESSSES TO BE DESIGNED AND CONSTRUCTED BY PROJECT CO

LEGEND			
ACCESS CLOSURE		CONNECTION REMOVAL	
NEW ACCESS		ROAD CLOSURE	

ACCESS CLOSURES			
ID	CLOSURE TYPE	STREET ADDRESS	PROPERTY TYPE
128-J	ROAD	140 STREET NW	PUBLIC
128-S	NEW ALLEY	13818 - 102 AVENUE NW	PUBLIC

no.	description	date	checked
2	RFP V4	18-09-20	JM
1	RFP V3	07-23-20	JM
0	RFP	02-29-20	JM
revisions			

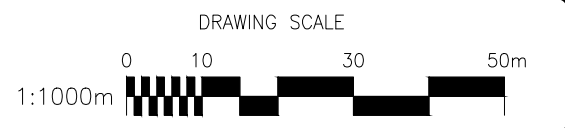

NOT FOR CONSTRUCTION



ACCESS, ALLEY & ROAD CLOSURES

DRAWING NO: 5-3A-29



ACCESS CLOSURES			
ID	CLOSURE TYPE	STREET ADDRESS	PROPERTY TYPE
128-S	NEW ALLEY	13818 - 102 AVENUE NW	PUBLIC
129-A	ACCESS	13818 - 102 AVENUE NW	RESIDENTIAL
129-B	CONNECTION REMOVAL	BETWEEN 138 STREET NW and 139 STREET NW	PUBLIC
129-D	ACCESS	13808 - STONY PLAIN ROAD NW	RESIDENTIAL
129-J	CONNECTION REMOVAL	BETWEEN 137 STREET NW and 138 STREET NW	PUBLIC

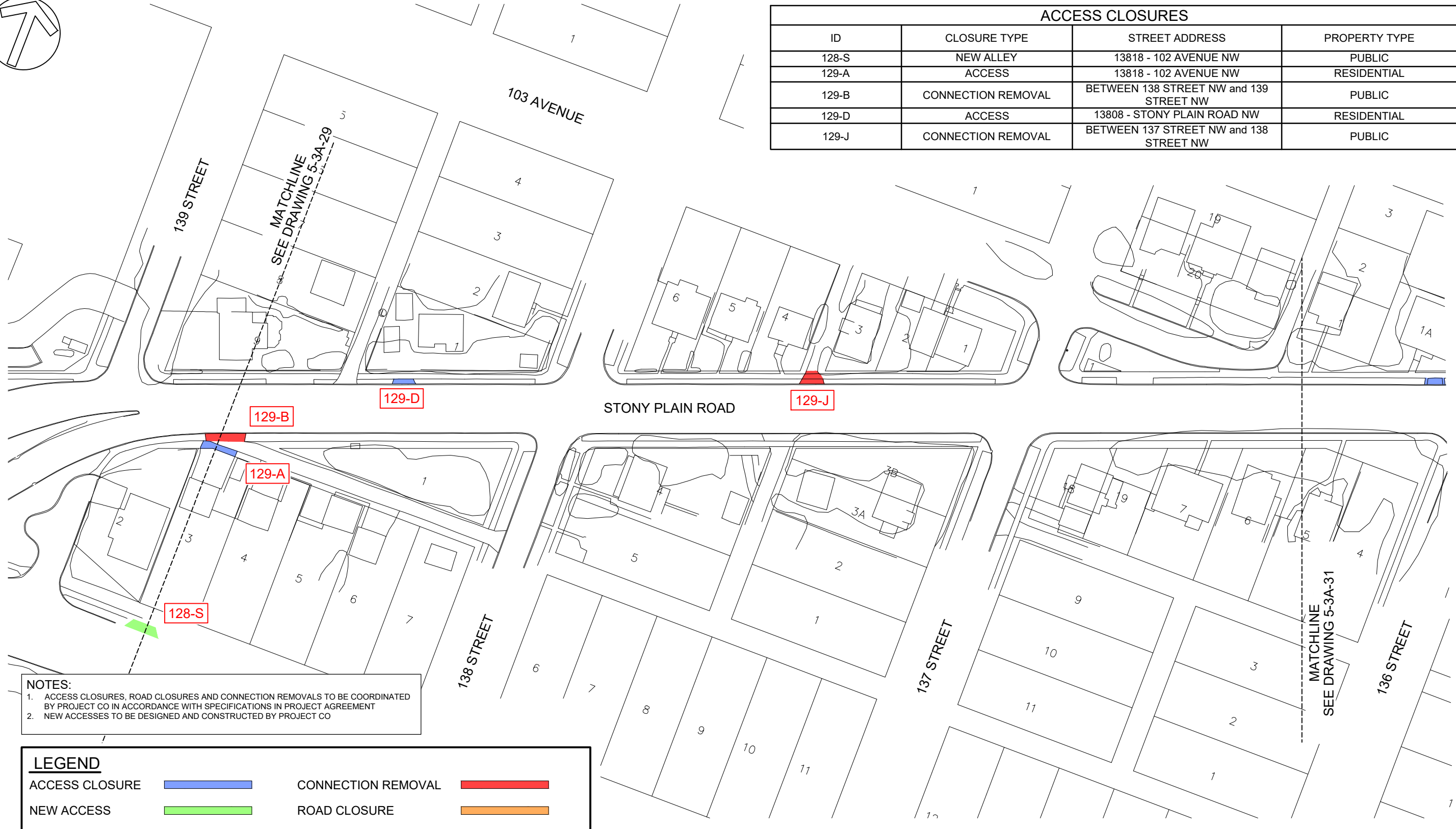

NOTES:
 1. ACCESS CLOSURES, ROAD CLOSURES AND CONNECTION REMOVALS TO BE COORDINATED BY PROJECT CO IN ACCORDANCE WITH SPECIFICATIONS IN PROJECT AGREEMENT
 2. NEW ACCESSSES TO BE DESIGNED AND CONSTRUCTED BY PROJECT CO

LEGEND			
ACCESS CLOSURE		CONNECTION REMOVAL	
NEW ACCESS		ROAD CLOSURE	

no.	description	date	checked
2	RFP V4	18-09-20	JM
1	RFP V3	07-23-20	JM
0	RFP	02-21-20	JM

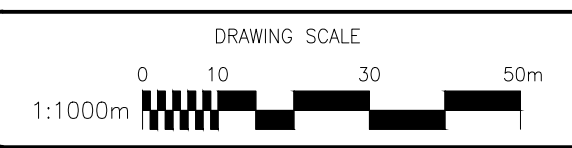

NOT FOR CONSTRUCTION



ISL Engineering
 MOTT MACDONALD

ACCESS, ALLEY & ROAD CLOSURES

DRAWING NO: 5-3A-30

AAAMND / September 8, 2020 / I:\EDMONTON\GLOBAL\PROJECTS\140001480014854_VALLEY_LINE_LRT_WEST_DESIGN_OE\02_CADD\30_DRAFTING\2300_ROADWAY\06_STAGE_2\ACCESS & ROAD_CLOSURES\5-3A-30.DWG

VALLEY LINE WEST LRT

A:\ANAND\September 8, 2020\1\EDMONTON\GLOBAL\PROJECTS\140001480014854_VALLEY_LINE_LRT_WEST_DESIGN_OE\02_CADD\00_DRAFTING\2300_ROADWAY\06_STAGE 2 ACCESS & ROAD CLOSURES\5-3A-31.DWG

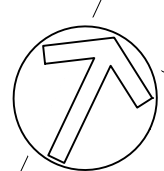

ACCESS CLOSURES			
ID	CLOSURE TYPE	STREET ADDRESS	PROPERTY TYPE
130-E	ACCESS	13606 - 103 AVENUE NW	RESIDENTIAL
130-L	ACCESS	13428 - 103 AVENUE NW	RESIDENTIAL
130-M	CONNECTION REMOVAL	BETWEEN 134 STREET NW and 135 STREET NW	PUBLIC
130-O	ACCESS	10320 - 134 STREET NW	RESIDENTIAL
130-Q	ACCESS	10327 - 135 STREET NW	RESIDENTIAL
130-W	ACCESS	10327 - 134 STREET NW	RESIDENTIAL

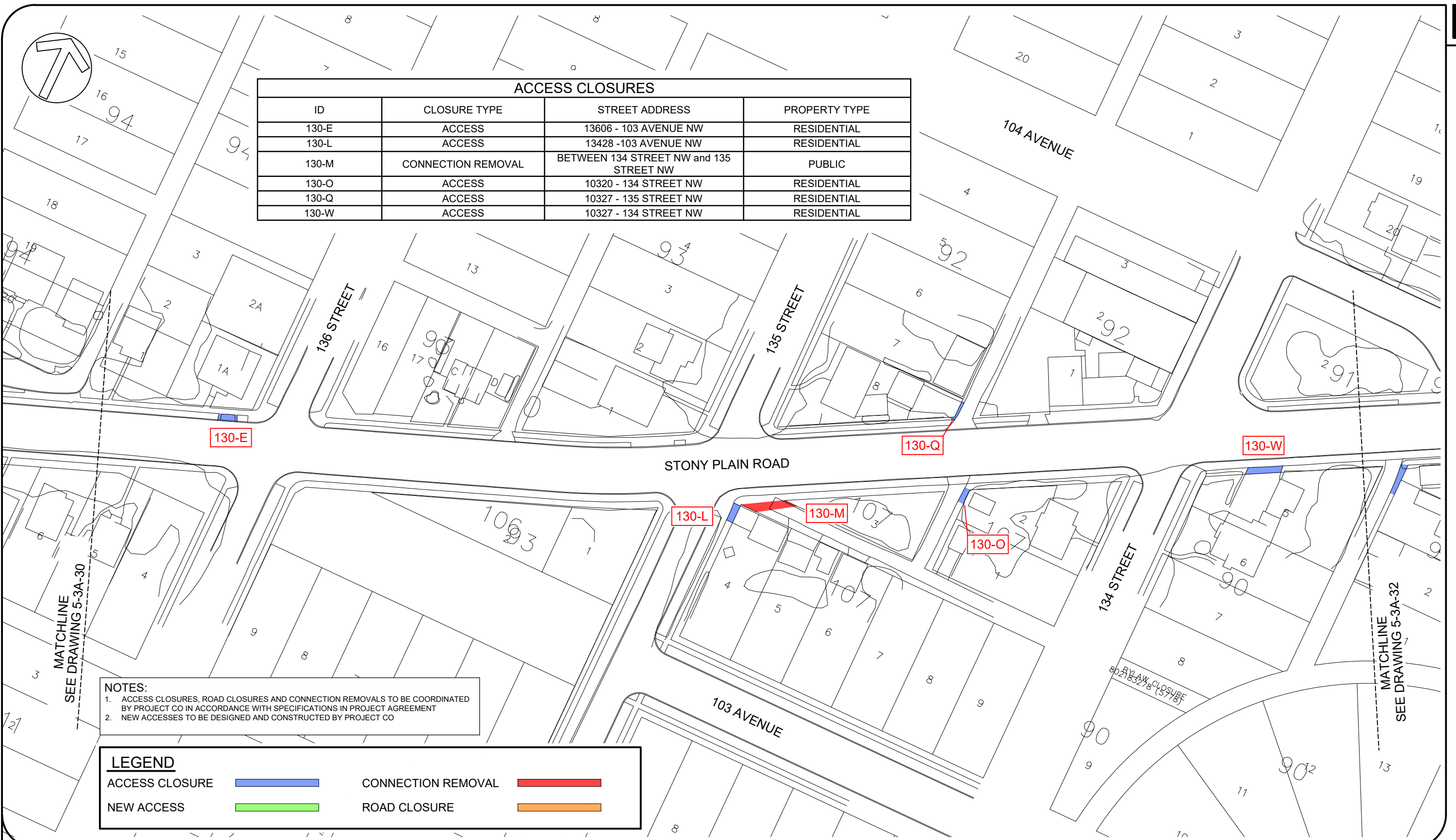

NOTES:
 1. ACCESS CLOSURES, ROAD CLOSURES AND CONNECTION REMOVALS TO BE COORDINATED BY PROJECT CO IN ACCORDANCE WITH SPECIFICATIONS IN PROJECT AGREEMENT
 2. NEW ACCESSSES TO BE DESIGNED AND CONSTRUCTED BY PROJECT CO

LEGEND			
ACCESS CLOSURE		CONNECTION REMOVAL	
NEW ACCESS		ROAD CLOSURE	

no.	description	date	checked
2	RFP V4	18-09-20	JM
1	RFP V3	07-23-20	JM
0	RFP	02-21-20	JM
revisions			

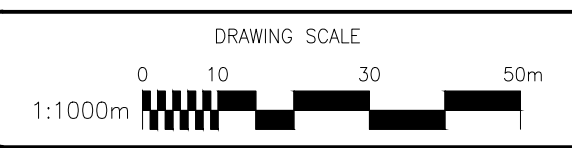

NOT FOR CONSTRUCTION



ACCESS, ALLEY & ROAD CLOSURES

DRAWING NO: 5-3A-31

VALLEY LINE WEST LRT

AAAMND / September 8, 2020 / I:\EDM\FILERS\GLOBAL\PROJECTS\140001480014854_VALLEY_LINE_LRT_WEST_DESIGN_OE\02_CADD\00_DRAFTING\2300_ROADWAY\06_STAGE 2 ACCESS & ROAD CLOSURES\5-3A-32.DWG



ACCESS CLOSURES			
ID	CLOSURE TYPE	STREET ADDRESS	PROPERTY TYPE
131-B	ACCESS	10348 - 133 STREET NW	RESIDENTIAL
131-L	ACCESS	10403 - 133 STREET NW	RESIDENTIAL
131-N	ACCESS	13210 STONY PLAIN ROAD NW	RESIDENTIAL
131-S	CONNECTION REMOVAL	BETWEEN GLENORA CRESCENT NW and 132 STREET NW	PUBLIC
131-T	ACCESS	13126 - 104 AVENUE NW	RESIDENTIAL
131-V	ACCESS	13122 STONY PLAIN ROAD NW	RESIDENTIAL
131-Y	ACCESS	10340 - 133 STREET NW	RESIDENTIAL

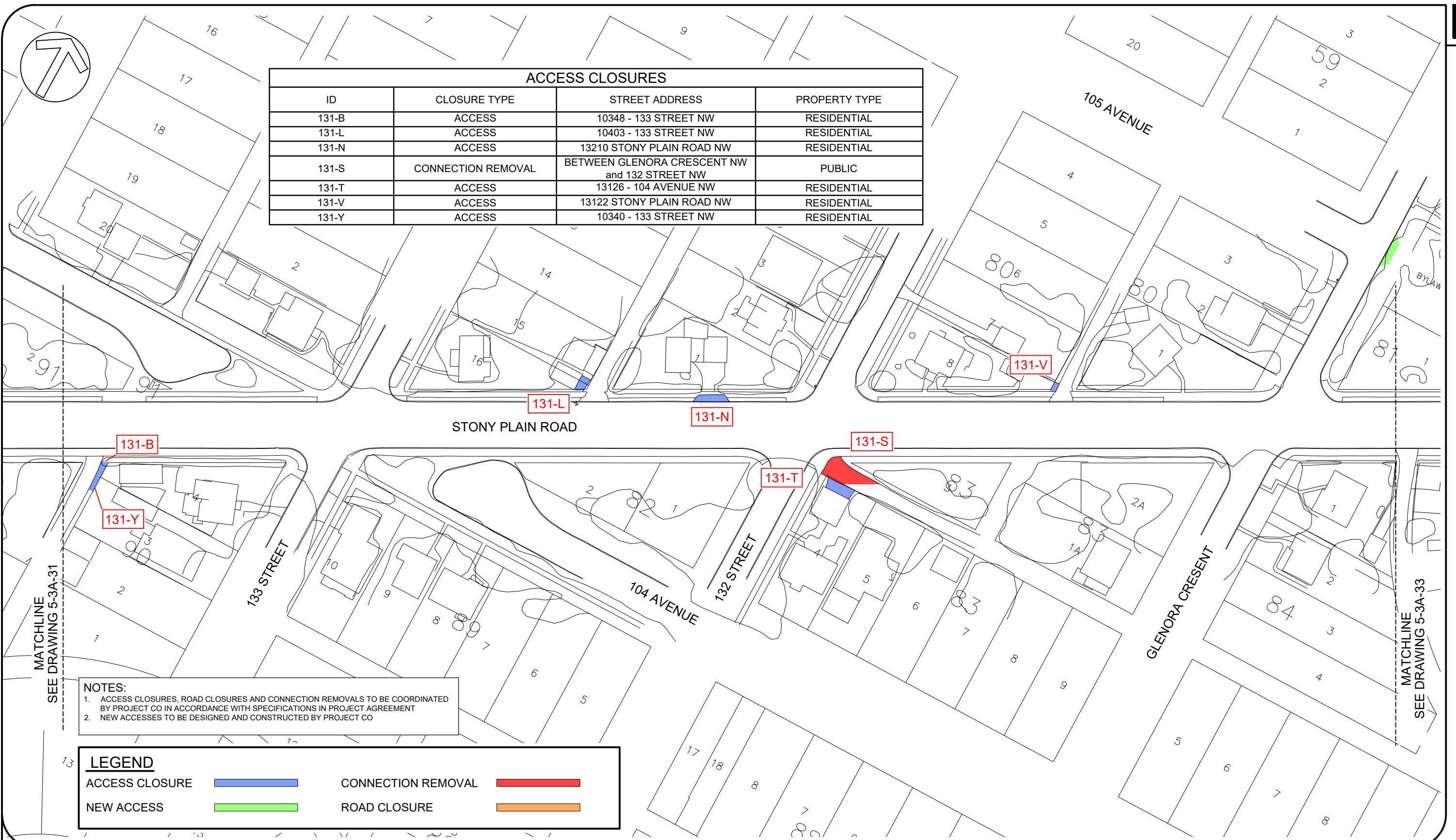

NOTES:
 1. ACCESS CLOSURES, ROAD CLOSURES AND CONNECTION REMOVALS TO BE COORDINATED BY PROJECT CO IN ACCORDANCE WITH SPECIFICATIONS IN PROJECT AGREEMENT
 2. NEW ACCESSSES TO BE DESIGNED AND CONSTRUCTED BY PROJECT CO

LEGEND			
ACCESS CLOSURE		CONNECTION REMOVAL	
NEW ACCESS		ROAD CLOSURE	

no.	description	date	checked
2	RFP V4	18-09-20	JM
1	RFP V3	07-23-20	JM
0	RFP	02-21-20	JM
	revisions		

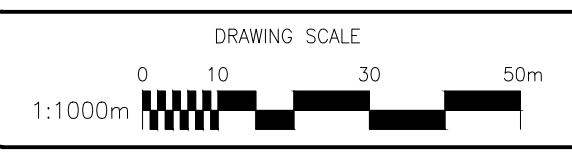

NOT FOR CONSTRUCTION

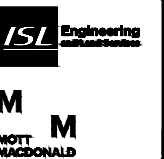

ACCESS, ALLEY & ROAD CLOSURES

DRAWING NO: 5-3A-32

VALLEY LINE WEST LRT

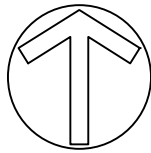

ACCESS CLOSURES			
ID	CLOSURE TYPE	STREET ADDRESS	PROPERTY TYPE
132-A	NEW ALLEY	10455 - 131 STREET (SAMUEL DICKSON ROTARY PARK)	PUBLIC
132-C	ACCESS	10446 CONNAUGHT DRIVE NW	RESIDENTIAL
132-D	CONNECTION RMEOVAL	BETWEEN GROAT ROAD and 131 STREET NW	PUBLIC
132-I	ACCESS	12903 - STONY PLAIN ROAD	RESIDENTIAL
132-J	ACCESS	12825 - STONY PLAIN ROAD	RESIDENTIAL
132-N	ACCESS	12803 WOODBEND PLACE NW	RESIDENTIAL
132-P	CONNECTION REMOVAL	GLENORA POINTE	PUBLIC
132-S	ACCESS	1 GLENORA POINTE NW	RESIDENTIAL
132-T	ACCESS	12821U - STONY PLAIN ROAD	PUBLIC

A:\ANAND\1 September 8, 2020\1\EDM\FILERS\GLOBAL\PROJECTS\140001480014854 - VALLEY LINE LRT - WEST DESIGN - OE\02_CADD\00_DRAFTING\2300_ROADWAY\06_STAGE 2 ACCESS & ROAD CLOSURES\5-3A-33.DWG

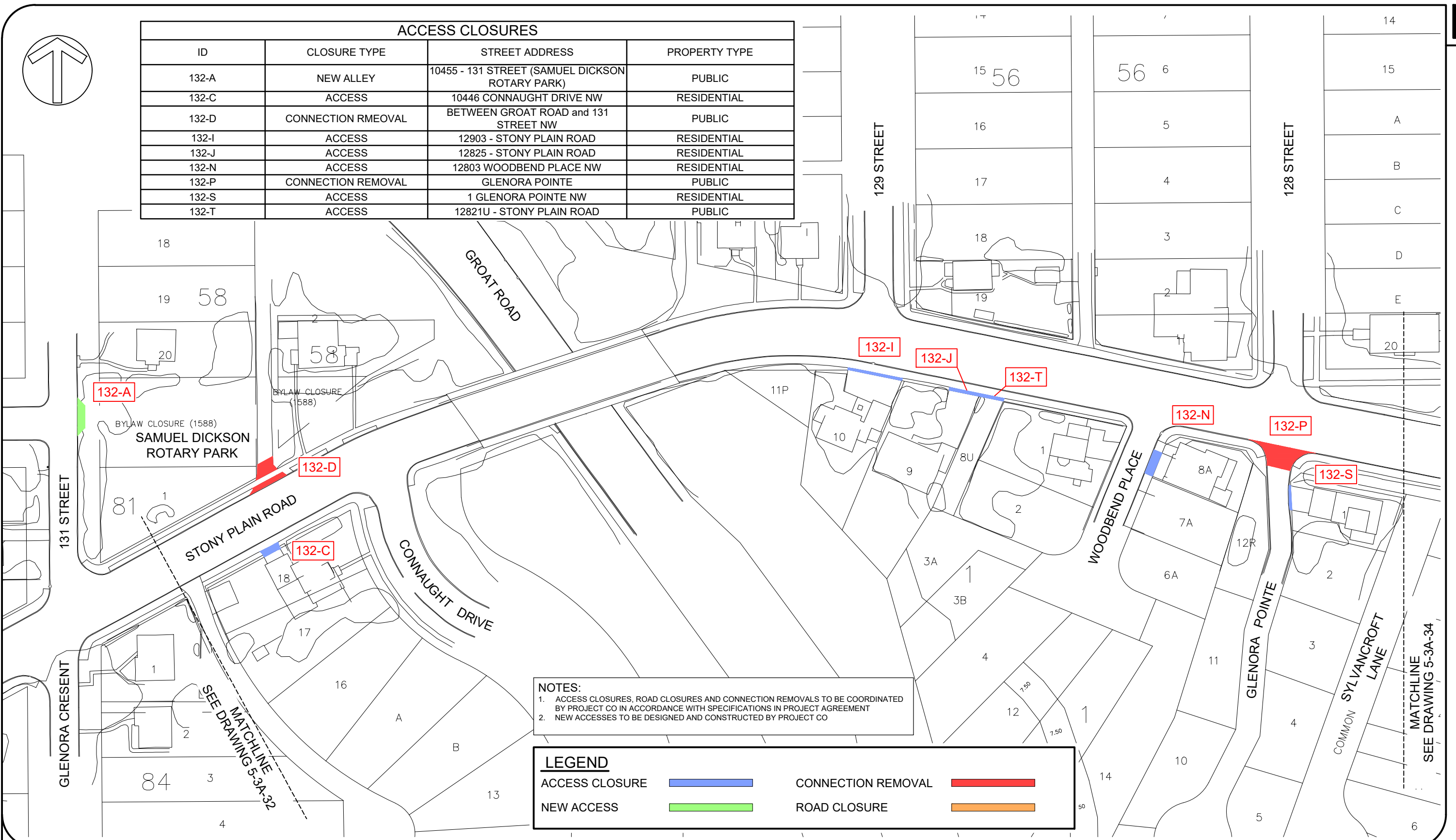

NOTES:
 1. ACCESS CLOSURES, ROAD CLOSURES AND CONNECTION REMOVALS TO BE COORDINATED BY PROJECT CO IN ACCORDANCE WITH SPECIFICATIONS IN PROJECT AGREEMENT
 2. NEW ACCESSSES TO BE DESIGNED AND CONSTRUCTED BY PROJECT CO

LEGEND	
ACCESS CLOSURE	
NEW ACCESS	
CONNECTION REMOVAL	
ROAD CLOSURE	

no.	description	date	checked
2	RFP V4	18-09-20	JM
1	RFP V3	07-23-20	JM
0	RFP	02-21-20	JM
	revisions		

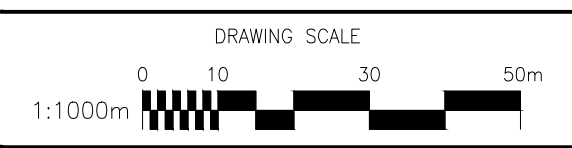

NOT FOR CONSTRUCTION



ISL Engineering

MOTT MACDONALD

ACCESS, ALLEY & ROAD CLOSURES

DRAWING NO: 5-3A-33

VALLEY LINE WEST LRT

AAAMND / September 8, 2020 / I:\EDM\FILERS\GLOBAL\PROJECTS\140001480014854_VALLEY_LINE_LRT_WEST_DESIGN_OE\02_CADD\00_DRAFTING\2300_ROADWAY\06_STAGE 2 ACCESS & ROAD CLOSURES\5-3A-34.DWG

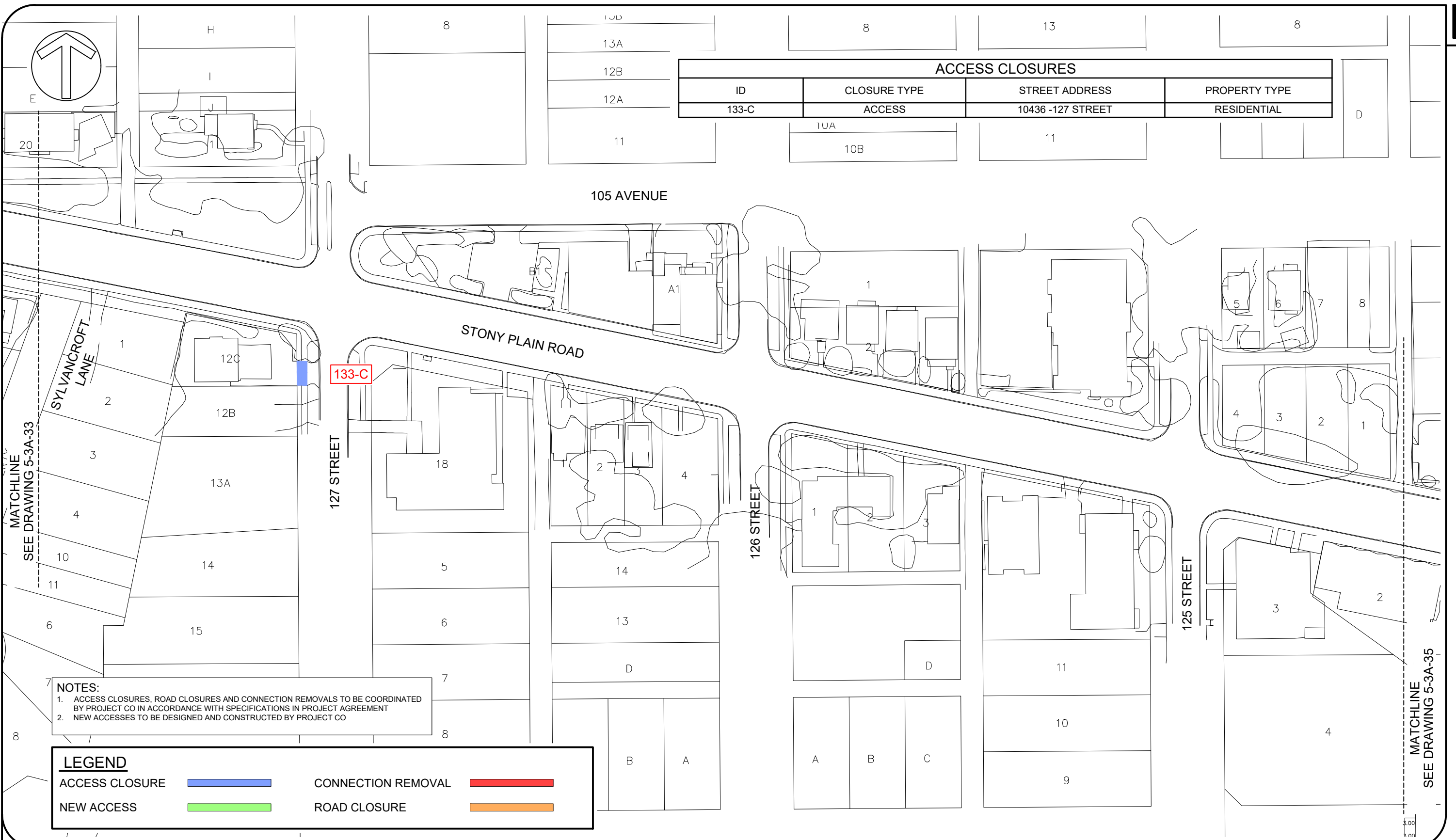

ACCESS CLOSURES			
ID	CLOSURE TYPE	STREET ADDRESS	PROPERTY TYPE
133-C	ACCESS	10436 -127 STREET	RESIDENTIAL

- NOTES:**
- ACCESS CLOSURES, ROAD CLOSURES AND CONNECTION REMOVALS TO BE COORDINATED BY PROJECT CO IN ACCORDANCE WITH SPECIFICATIONS IN PROJECT AGREEMENT
 - NEW ACCESSSES TO BE DESIGNED AND CONSTRUCTED BY PROJECT CO

LEGEND			
ACCESS CLOSURE		CONNECTION REMOVAL	
NEW ACCESS		ROAD CLOSURE	

no.	description	date	checked
2	RFP V4	18-09-20	JM
1	RFP V3	07-23-20	JM
0	RFP	02-21-20	JM
revisions			

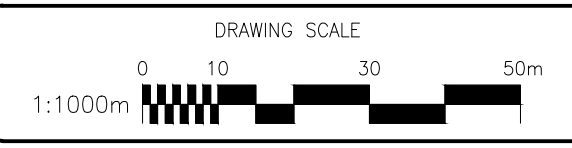

NOT FOR CONSTRUCTION

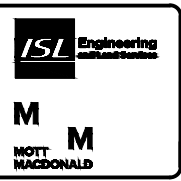

ACCESS, ALLEY & ROAD CLOSURES

DRAWING NO: 5-3A-34

VALLEY LINE WEST LRT

AA\AMND\September 8, 2020\1\EDM\FILES\GLOBAL\PROJECTS\140001480014854_VALLEY_LINE_LRT_WEST_DESIGN_OE\02_CADD\00_DRAFTING\2300_ROADWAY\06_STAGE 2 ACCESS & ROAD CLOSURES\5-3A-35.DWG

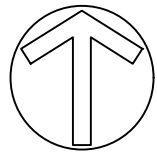

MATCHLINE
SEE DRAWING 5-3A-34

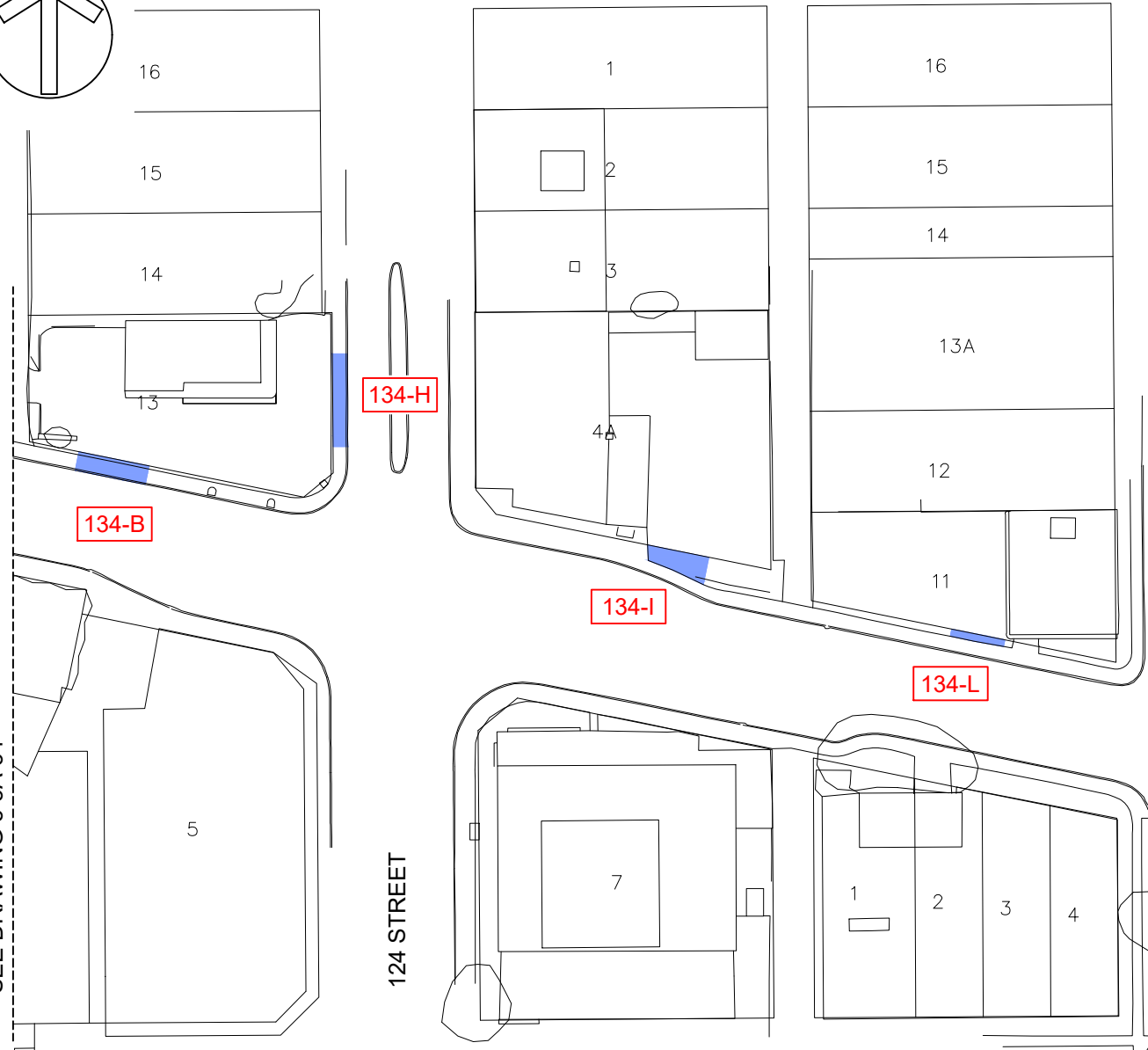

ACCESS CLOSURES			
ID	CLOSURE TYPE	STREET ADDRESS	PROPERTY TYPE
134-B	ACCESS	10426 - 124 STREET NW	COMMERCIAL
134-H	ACCESS	10426 - 124 STREET NW	COMMERCIAL
134-I	ACCESS	10429 - 124 STREET NW	COMMERCIAL
134-L	ACCESS	12302 STONY PLAIN ROAD NW	COMMERCIAL

123 STREET

122 STREET

STONY PLAIN ROAD

124 STREET

104 AVENUE

MATCHLINE
SEE DRAWING 5-3A-36

VALLEY LINE WEST LRT

NOTES:
 1. ACCESS CLOSURES, ROAD CLOSURES AND CONNECTION REMOVALS TO BE COORDINATED BY PROJECT CO IN ACCORDANCE WITH SPECIFICATIONS IN PROJECT AGREEMENT
 2. NEW ACCESSES TO BE DESIGNED AND CONSTRUCTED BY PROJECT CO

LEGEND			
ACCESS CLOSURE		CONNECTION REMOVAL	
NEW ACCESS		ROAD CLOSURE	

no.	description	date	checked
2	RFP V4	18-09-20	JM
1	RFP V3	07-23-20	JM
0	RFP	02-21-20	JM
	revisions		

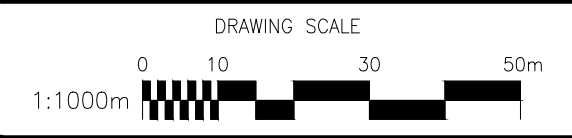

NOT FOR CONSTRUCTION



ACCESS, ALLEY & ROAD CLOSURES

DRAWING NO: 5-3A-35

AAAMND / September 8, 2020 / I:\EDM\FILERS\GLOBAL\PROJECTS\140001480014854_VALLEY_LINE_LRT_WEST_DESIGN_OE\02_CADD\00_DRAFTING\2300_ROADWAY\06_STAGE 2 ACCESS & ROAD CLOSURES\5-3A-36.DWG

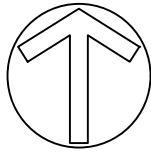

ACCESS CLOSURES			
ID	CLOSURE TYPE	STREET ADDRESS	PROPERTY TYPE
135-L	ACCESS	10344 - 119 STREET NW	RESIDENTIAL

MATCHLINE
SEE DRAWING 5-3A-35

121 STREET

120 STREET

MATCHLINE
SEE DRAWING 5-3A-37

104 AVENUE

119 STREET

VALLEY LINE WEST LRT

NOTES:

1. ACCESS CLOSURES, ROAD CLOSURES AND CONNECTION REMOVALS TO BE COORDINATED BY PROJECT CO IN ACCORDANCE WITH SPECIFICATIONS IN PROJECT AGREEMENT
2. NEW ACCESSSES TO BE DESIGNED AND CONSTRUCTED BY PROJECT CO

LEGEND

ACCESS CLOSURE		CONNECTION REMOVAL	
NEW ACCESS		ROAD CLOSURE	

no.	description	date	checked
2	RFP V4	18-09-20	JM
1	RFP V3	07-23-20	JM
0	RFP	02-21-20	JM
revisions			

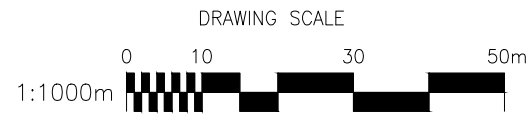

NOT FOR
CONSTRUCTION



ACCESS, ALLEY & ROAD CLOSURES

DRAWING NO: 5-3A-36

135-L

59

341

342

343

346

45A

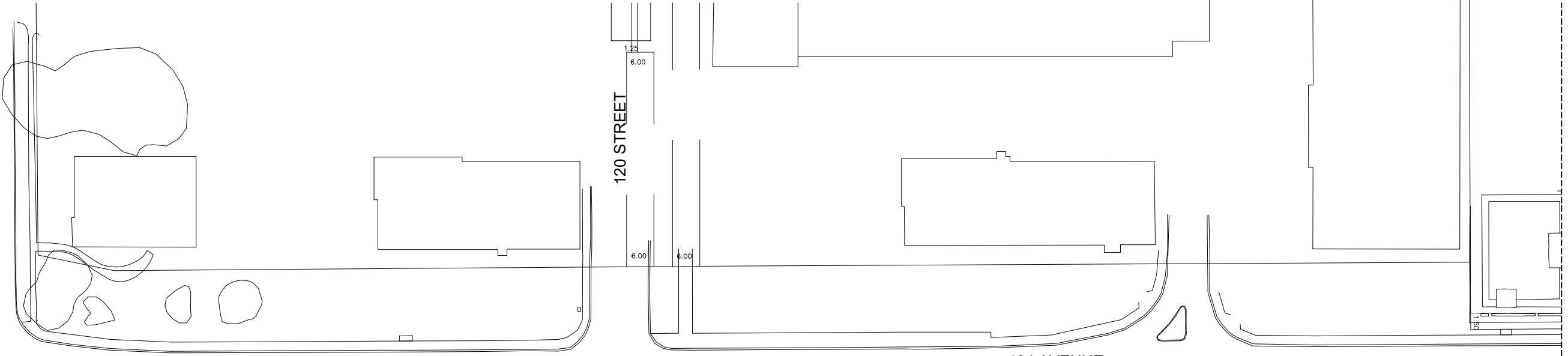

AA\AMND\September 8, 2020\1\EDM\FILER\ISL\GLOBAL\PROJECTS\140001480014854_VALLEY_LINE_LRT_WEST_DESIGN_OE\02_CADD\30_DRAFTING\3000_ROADWAY\9\06_STAGE 2 ACCESS & ROAD CLOSURES\5-3A-37.DWG

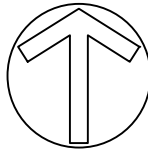

MATCHLINE
SEE DRAWING 5-3A-36

ACCESS CLOSURES			
ID	CLOSURE TYPE	STREET ADDRESS	PROPERTY TYPE
136-J	ACCESS	11603 - 104 AVENUE NW	COMMERCIAL

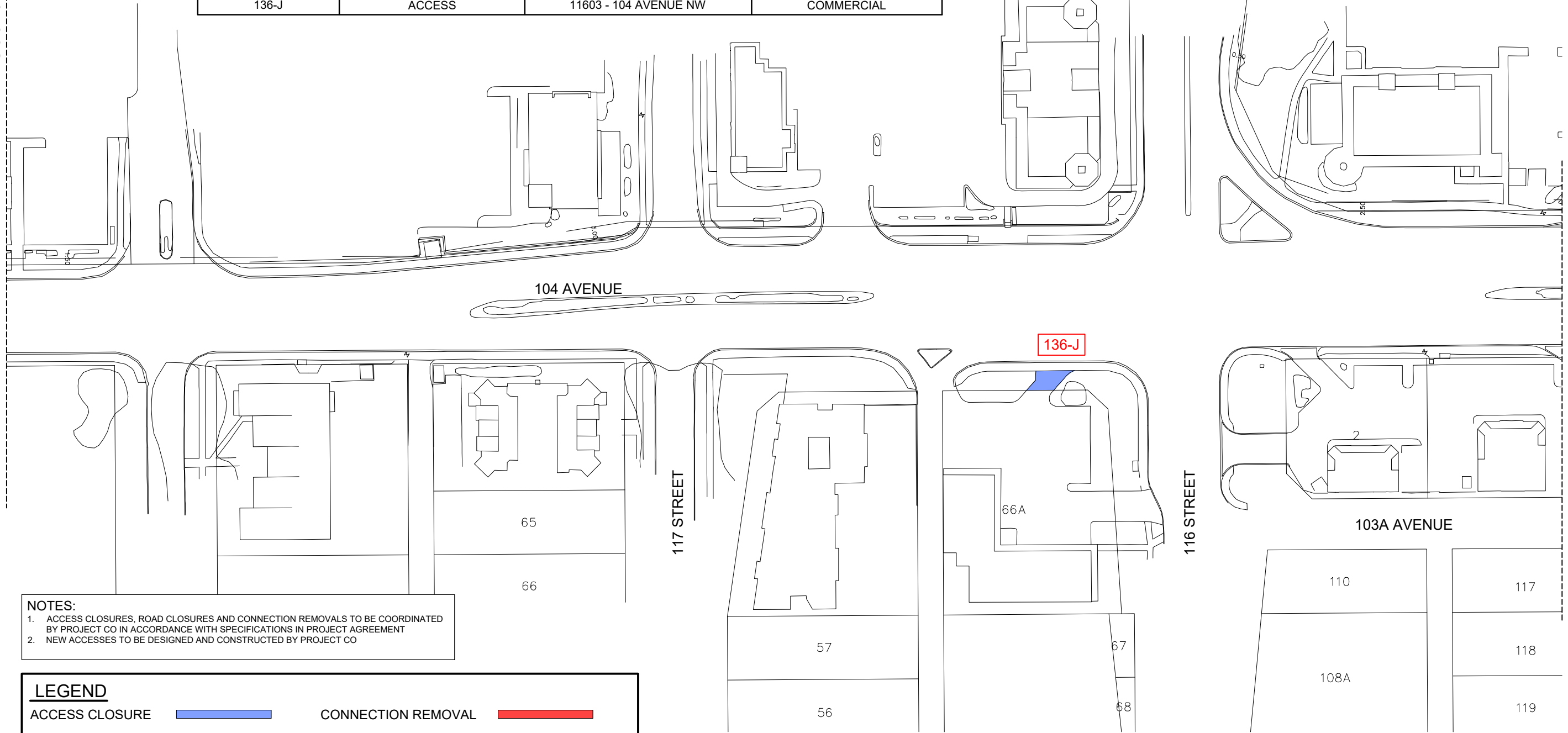

MATCHLINE
SEE DRAWING 5-3A-38

VALLEY LINE WEST LRT

NOTES:

- ACCESS CLOSURES, ROAD CLOSURES AND CONNECTION REMOVALS TO BE COORDINATED BY PROJECT CO IN ACCORDANCE WITH SPECIFICATIONS IN PROJECT AGREEMENT
- NEW ACCESSSES TO BE DESIGNED AND CONSTRUCTED BY PROJECT CO

LEGEND

ACCESS CLOSURE		CONNECTION REMOVAL	
NEW ACCESS		ROAD CLOSURE	

no.	description	date	checked
2	RFP V4	18-09-20	JM
1	RFP V3	07-23-20	JM
0	RFP	02-21-20	JM
revisions			

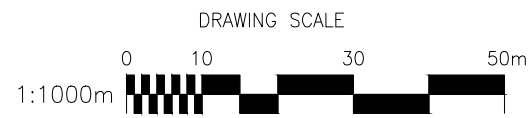

NOT FOR CONSTRUCTION



ACCESS, ALLEY & ROAD CLOSURES

DRAWING NO: 5-3A-37

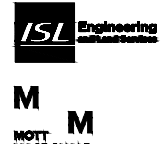

AAAMND / September 8, 2020 / I:\EDM\FILER\ISL\GLOBAL\PROJECTS\140001480014854_VALLEY_LINE_LRT_WEST_DESIGN_OE\02_CADD\00_DRAFTING\2300_ROADWAY\06_STAGE 2 ACCESS & ROAD CLOSURES\5-3A-38.DWG

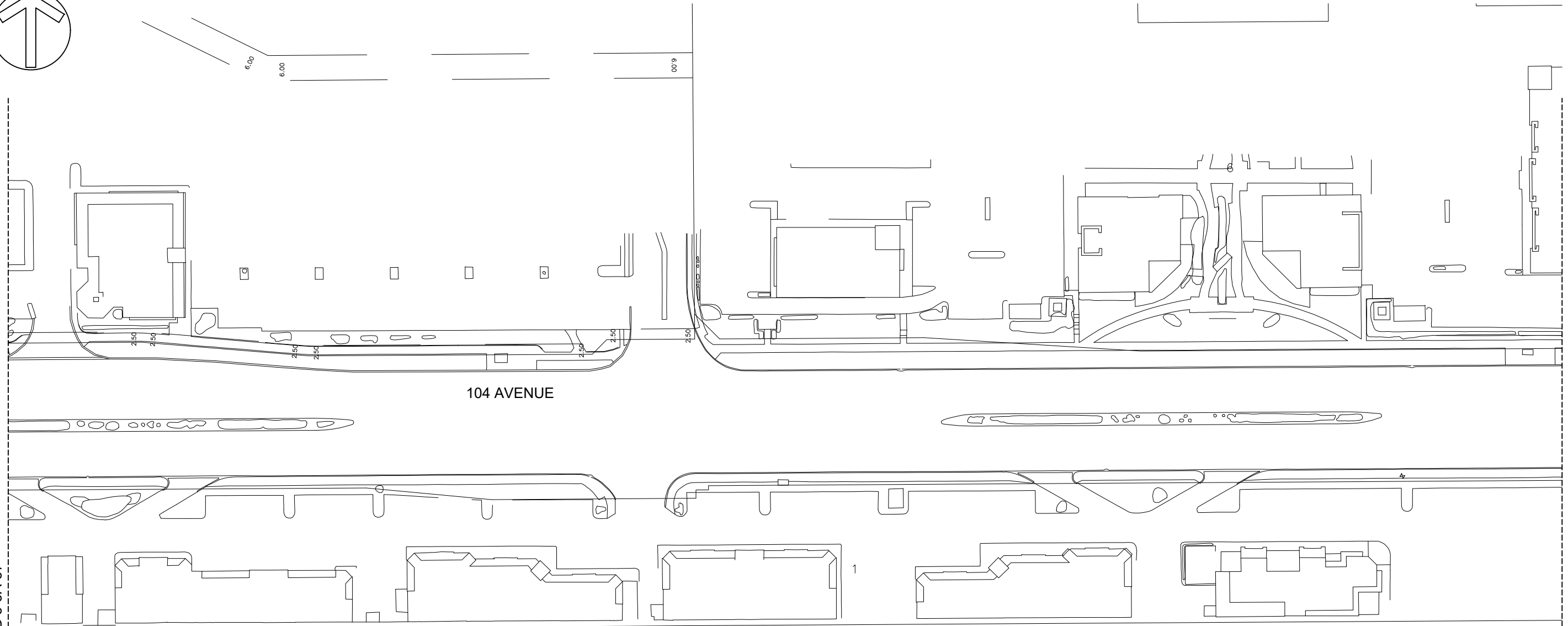
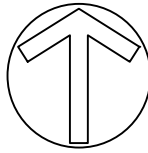

MATCHLINE
SEE DRAWING 5-3A-39

MATCHLINE
SEE DRAWING 5-3A-37

104 AVENUE

103A AVENUE

114 STREET

113 STREET

110

117

145

144

143

131

NOTES:
 1. ACCESS CLOSURES, ROAD CLOSURES AND CONNECTION REMOVALS TO BE COORDINATED BY PROJECT CO IN ACCORDANCE WITH SPECIFICATIONS IN PROJECT AGREEMENT
 2. NEW ACCESSSES TO BE DESIGNED AND CONSTRUCTED BY PROJECT CO

LEGEND			
ACCESS CLOSURE		CONNECTION REMOVAL	
NEW ACCESS		ROAD CLOSURE	

no.	description	date	checked
2	RFP V4	18-09-20	JM
1	RFP V3	07-23-20	JM
0	RFP	02-21-20	JM
revisions			

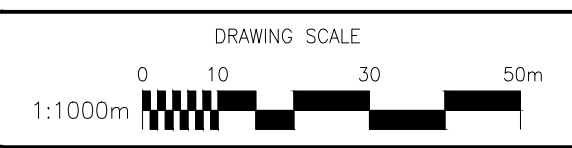

NOT FOR CONSTRUCTION



ACCESS, ALLEY & ROAD CLOSURES

DRAWING NO: 5-3A-38

VALLEY LINE WEST LRT

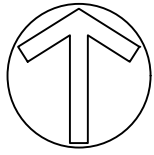

MATCHLINE
SEE DRAWING 5-3A-38

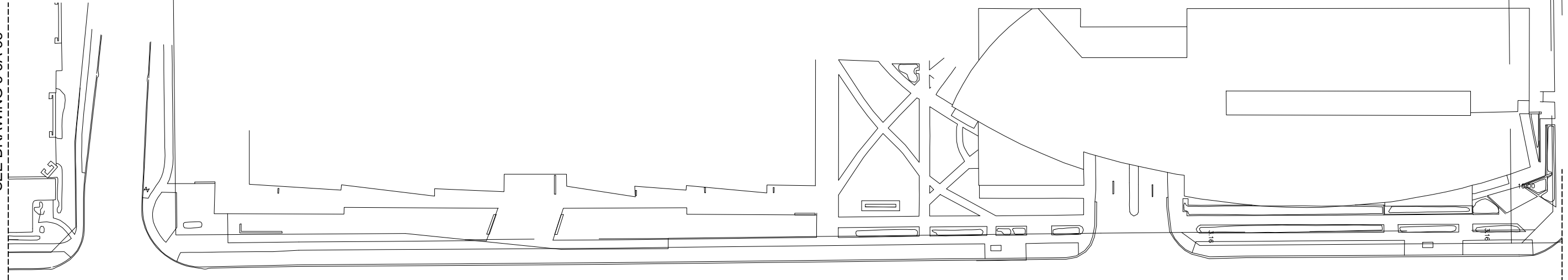

104 AVENUE

112 STREET

111 STREET

110 STREET

MATCHLINE
SEE DRAWING 5-3A-40

VALLEY LINE WEST LRT

NOTES:

1. ACCESS CLOSURES, ROAD CLOSURES AND CONNECTION REMOVALS TO BE COORDINATED BY PROJECT CO IN ACCORDANCE WITH SPECIFICATIONS IN PROJECT AGREEMENT
2. NEW ACCESSSES TO BE DESIGNED AND CONSTRUCTED BY PROJECT CO

LEGEND

ACCESS CLOSURE		CONNECTION REMOVAL	
NEW ACCESS		ROAD CLOSURE	

no.	description	date	checked
2	RFP V4	18-09-20	JM
1	RFP V3	07-23-20	JM
0	RFP	02-21-20	JM
revisions			

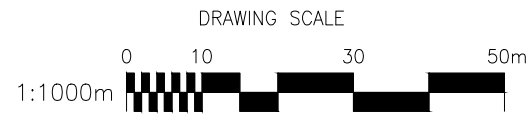

NOT FOR
CONSTRUCTION



ACCESS, ALLEY & ROAD CLOSURES

DRAWING NO: 5-3A-39

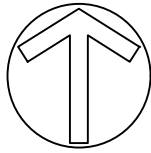

ACCESS CLOSURES			
ID	CLOSURE TYPE	STREET ADDRESS	PROPERTY TYPE
139-I	ACCESS	10340 - 107 STREET NW	COMMERCIAL
139-N	ACCESS	10340 - 107 STREET NW	COMMERCIAL
139-O	ACCESS	10340 - 107 STREET NW	COMMERCIAL
139-P	ACCESS	10316 - 107 STREET NW	COMMERCIAL
139-Q	ACCESS	10302 - 107 STREET NW	COMMERCIAL
139-R	ACCESS	10302 - 107 STREET NW	COMMERCIAL

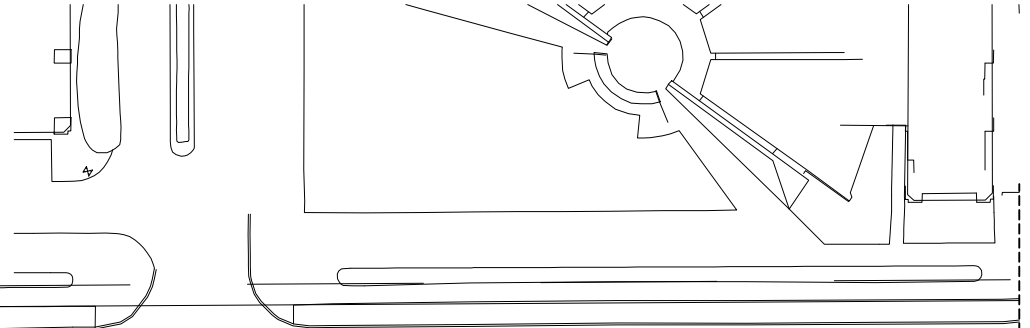

104 AVENUE

139-I

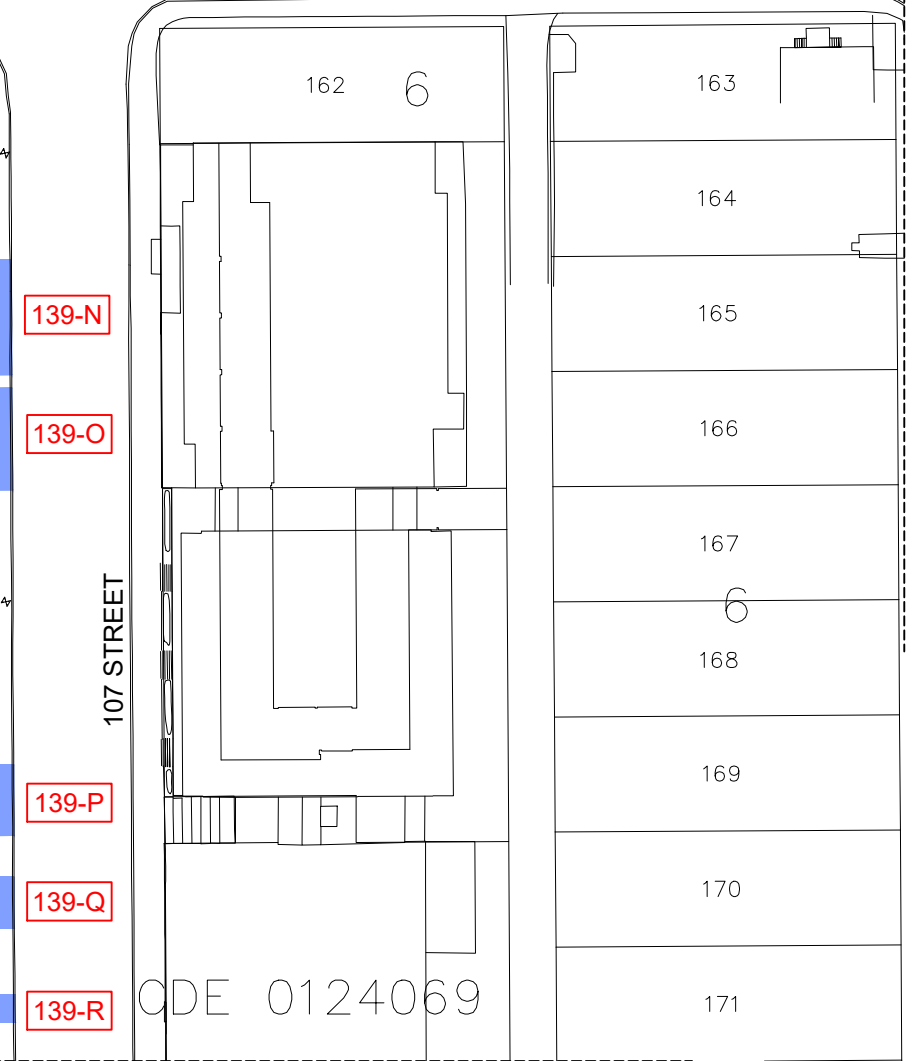
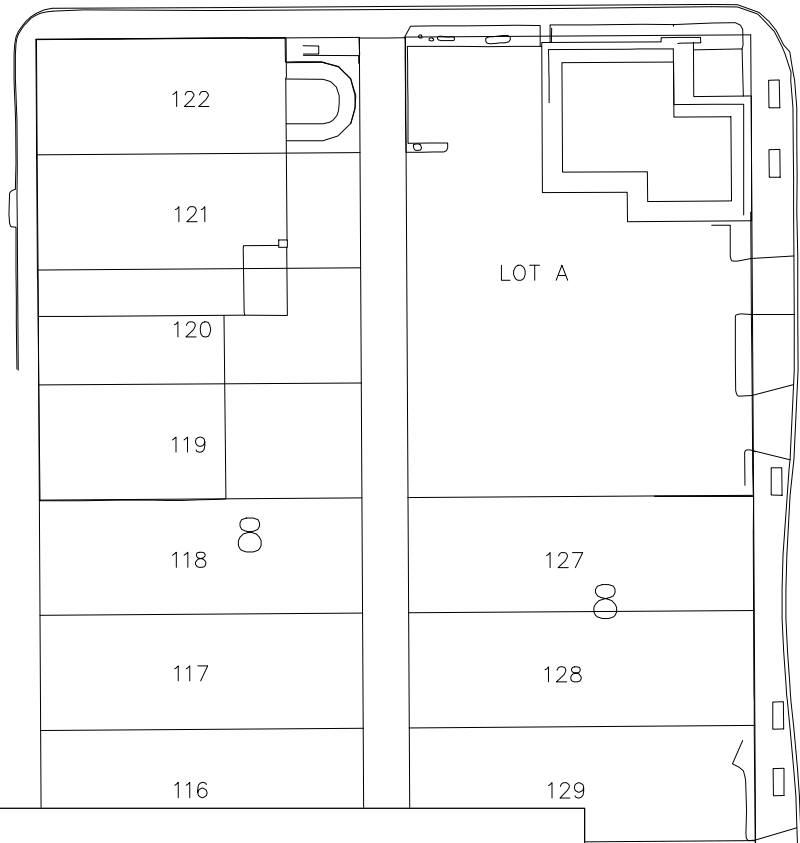

MATCHLINE
SEE DRAWING 5-3A-39

MATCHLINE
SEE DRAWING 5-3A-41

VALLEY LINE WEST LRT

NOTES:
 1. ACCESS CLOSURES, ROAD CLOSURES AND CONNECTION REMOVALS TO BE COORDINATED BY PROJECT CO IN ACCORDANCE WITH SPECIFICATIONS IN PROJECT AGREEMENT
 2. NEW ACCESSSES TO BE DESIGNED AND CONSTRUCTED BY PROJECT CO

LEGEND			
ACCESS CLOSURE		CONNECTION REMOVAL	
NEW ACCESS		ROAD CLOSURE	

no.	description	date	checked
2	RFP V4	18-09-20	JM
1	RFP V3	07-23-20	JM
0	RFP	02-21-20	JM

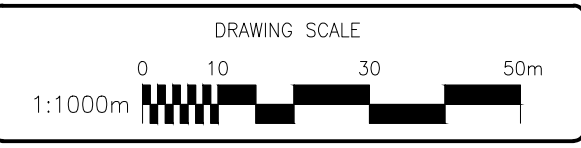

NOT FOR CONSTRUCTION

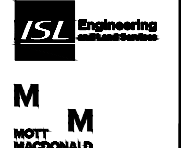

ACCESS, ALLEY & ROAD CLOSURES

DRAWING NO: 5-3A-40

A:\ANAND\September 8, 2020\1\EDMONTON\GLOBAL\PROJECTS\140001480014854_VALLEY_LINE_LRT_WEST_DESIGN_OE\02_CADD\30_DRAFTING\2300_ROADWAY\9\06_STAGE 2 ACCESS & ROAD CLOSURES\5-3A-40.DWG

AA/AMND / September 10, 2020 / IED/FILE/ISL_GLOBAL/PROJECTS/1400014854_VALLEY_LINE_LRT_WEST_DESIGN_DE/02_CADD/00_DRAFTING/2300_ROADWAYS/06_STAGE 2 ACCESS & ROAD CLOSURES/5-3A-41.DWG



NOTES:
 1. ACCESS CLOSURES, ROAD CLOSURES AND CONNECTION REMOVALS TO BE COORDINATED BY PROJECT CO IN ACCORDANCE WITH SPECIFICATIONS IN PROJECT AGREEMENT
 2. NEW ACCESSES TO BE DESIGNED AND CONSTRUCTED BY PROJECT CO

LEGEND

ACCESS CLOSURE		CONNECTION REMOVAL	
NEW ACCESS		ROAD CLOSURE	

no.	description	date	checked
2	RFP V4	18-09-20	JM
1	RFP V3	07-23-20	JM
0	RFP	02-21-20	JM
revisions			

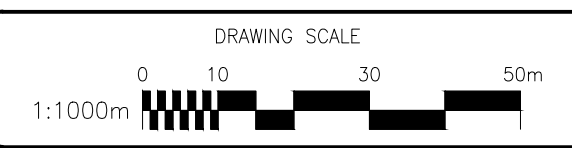

NOT FOR CONSTRUCTION



ACCESS, ALLEY & ROAD CLOSURES

DRAWING NO: 5-3A-41

VALLEY LINE WEST LRT

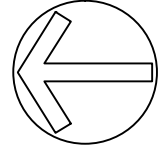

MATCHLINE
SEE DRAWING 5-3A-40

103 AVENUE

MATCHLINE
SEE DRAWING 5-3A-43

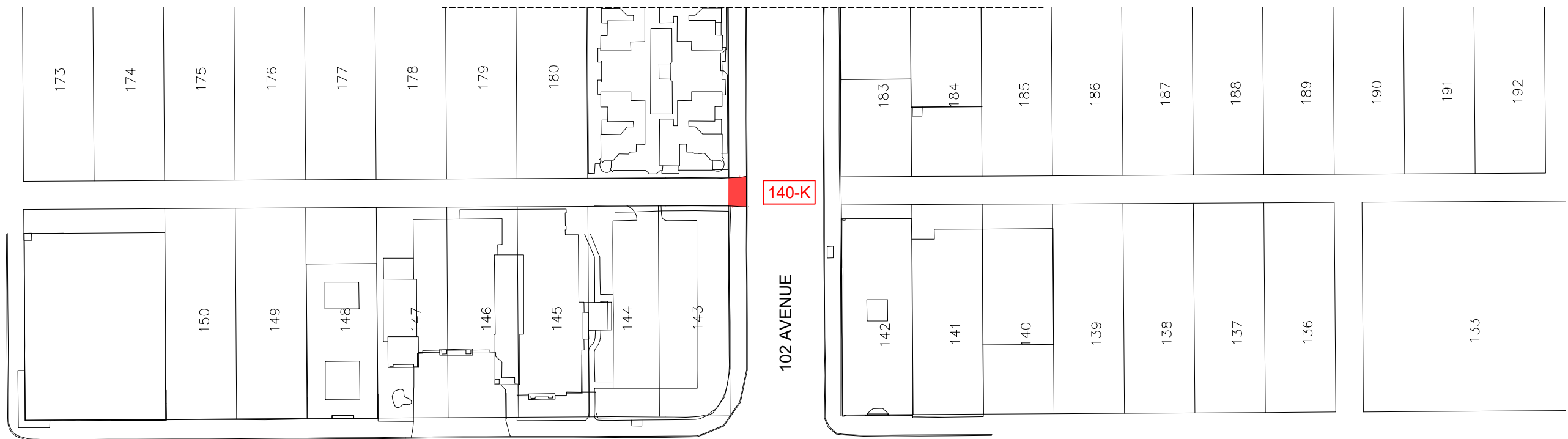

107 STREET

140-K

102 AVENUE

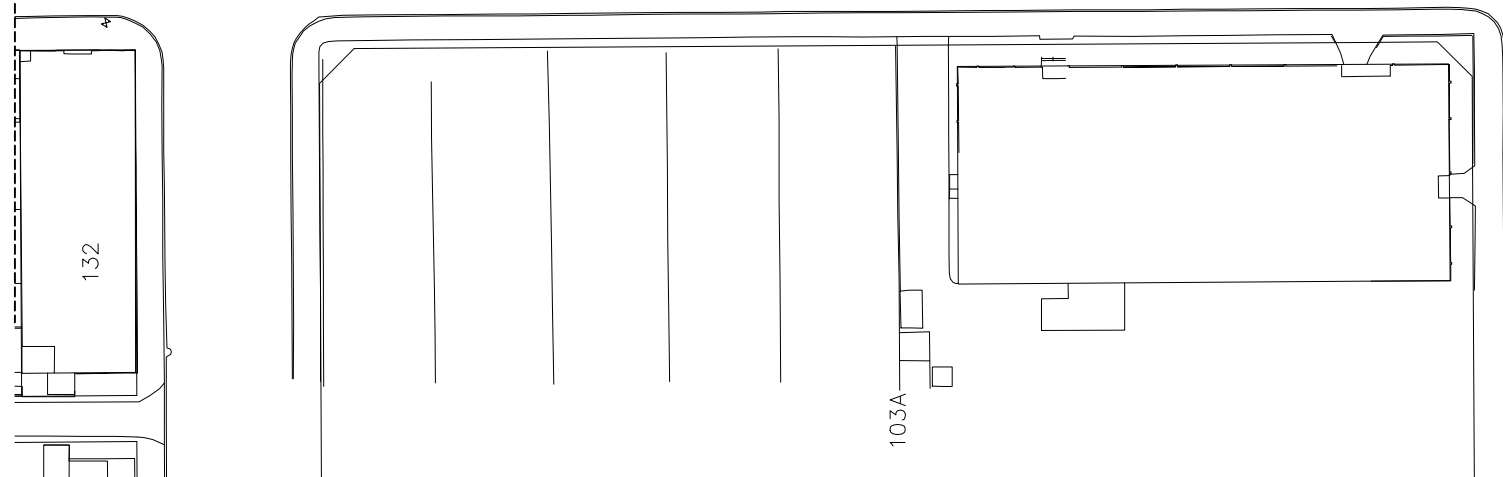

NOTES:
 1. ACCESS CLOSURES, ROAD CLOSURES AND CONNECTION REMOVALS TO BE COORDINATED BY PROJECT CO IN ACCORDANCE WITH SPECIFICATIONS IN PROJECT AGREEMENT
 2. NEW ACCESSSES TO BE DESIGNED AND CONSTRUCTED BY PROJECT CO

LEGEND			
ACCESS CLOSURE		CONNECTION REMOVAL	
NEW ACCESS		ROAD CLOSURE	

ACCESS CLOSURES			
ID	CLOSURE TYPE	STREET ADDRESS	PROPERTY TYPE
140-K	CONNECTION REMOVAL	BETWEEN 106 STREET NW and 107 STREET NW	PUBLIC

no.	description	date	checked
2	RFP V4	18-09-20	JM
1	RFP V3	07-23-20	JM
0	RFP	02-21-20	JM
revisions			

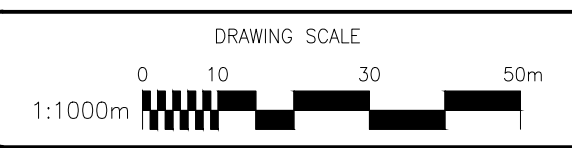

NOT FOR
CONSTRUCTION



ACCESS, ALLEY & ROAD CLOSURES

DRAWING NO: 5-3A-42

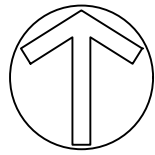

ACCESS CLOSURES			
ID	CLOSURE TYPE	STREET ADDRESS	PROPERTY TYPE
141-D	ACCESS	10536 - 102 AVENUE NW	COMMERCIAL
141-E	CONNECTION REMOVAL	BETWEEN 105 STREET NW and 106 STREET NW	PUBLIC
141-G	ACCESS	10180 - 105 STREET NW	COMMERCIAL
141-J	CONNECTION REMOVAL	BETWEEN 104 STREET NW and 105 STREET NW	PUBLIC
141-O	NEW ACCESS	10536 -102 AVENUE NW	COMMERCIAL

MATCHLINE
SEE DRAWING 5-3A-42

106 STREET

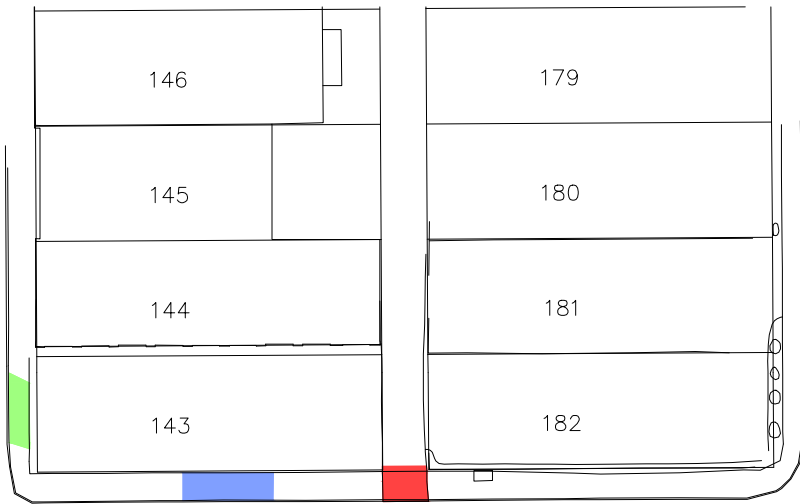

105 STREET

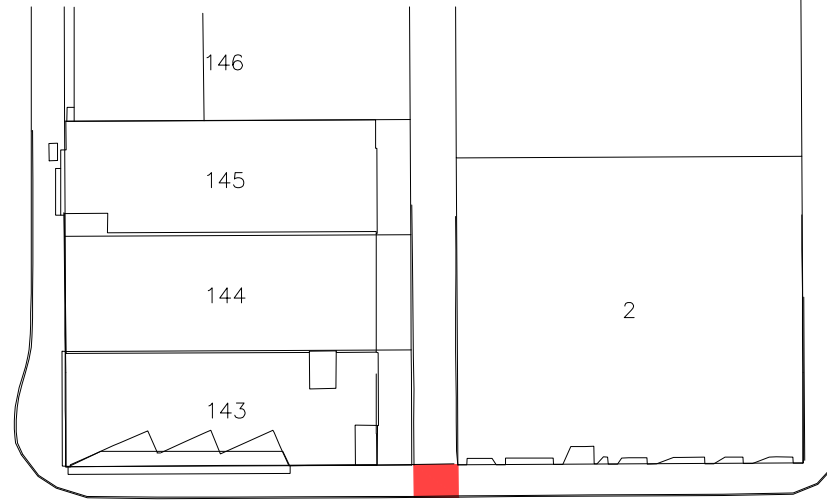

104 STREET

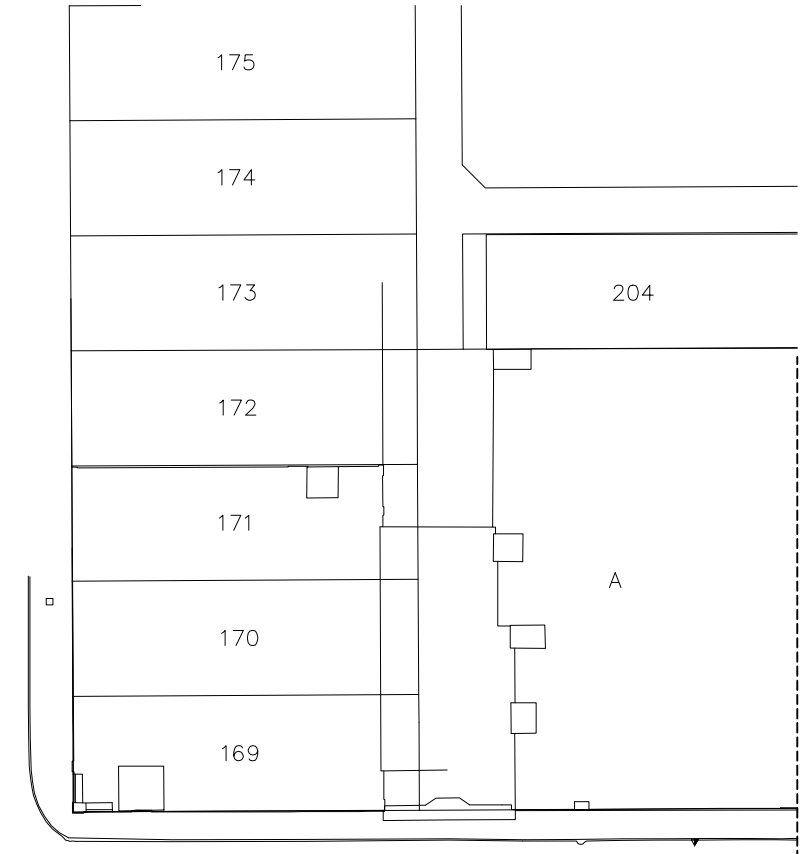

MATCHLINE
SEE DRAWING 5-3A-44

VALLEY LINE WEST LRT

102 AVENUE

141-D

141-E

141-J

141-G

NOTES:

1. ACCESS CLOSURES, ROAD CLOSURES AND CONNECTION REMOVALS TO BE COORDINATED BY PROJECT CO IN ACCORDANCE WITH SPECIFICATIONS IN PROJECT AGREEMENT
2. NEW ACCESSSES TO BE DESIGNED AND CONSTRUCTED BY PROJECT CO

LEGEND

ACCESS CLOSURE		CONNECTION REMOVAL	
NEW ACCESS		ROAD CLOSURE	

no.	description	date	checked
2	RFP V4	18-09-20	JM
1	RFP V3	07-23-20	JM
0	RFP	02-21-20	JM
revisions			

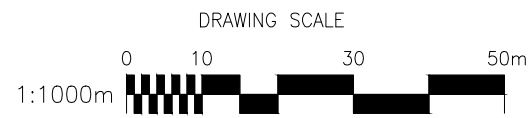

NOT FOR
CONSTRUCTION



ACCESS, ALLEY & ROAD CLOSURES

DRAWING NO: 5-3A-43

A:\AMAND \September 8, 2020 \MEDFILLER\ISL\GLOBAL\PROJECTS\140001480014854_VALLEY_LINE_LRT_WEST_DESIGN_OE\02_CADD\00_DRAFTING\2300_ROADWAY\06_STAGE 2 ACCESS & ROAD CLOSURES\5-3A-44.DWG

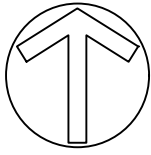

MATCHLINE
SEE DRAWING 5-3A-43

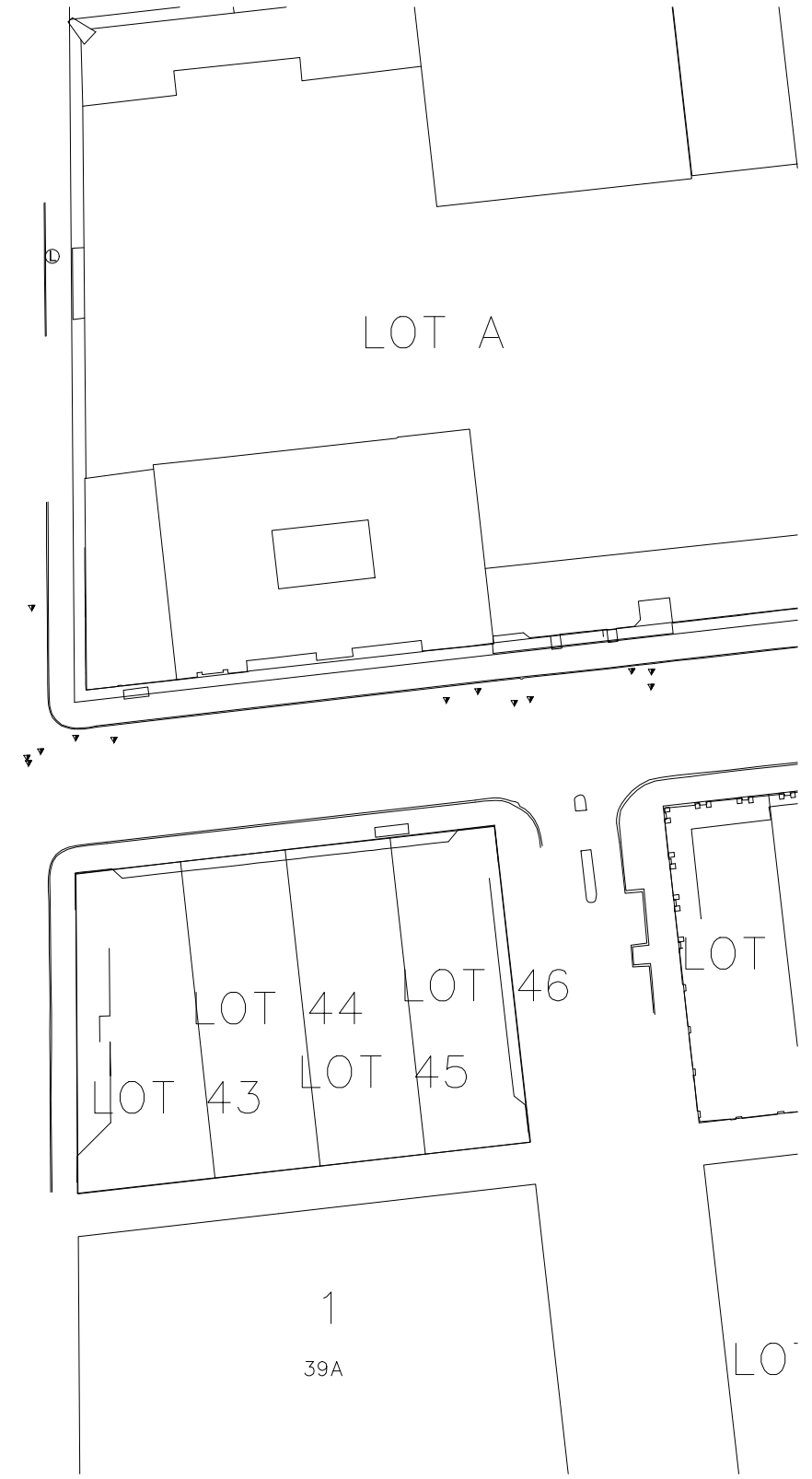
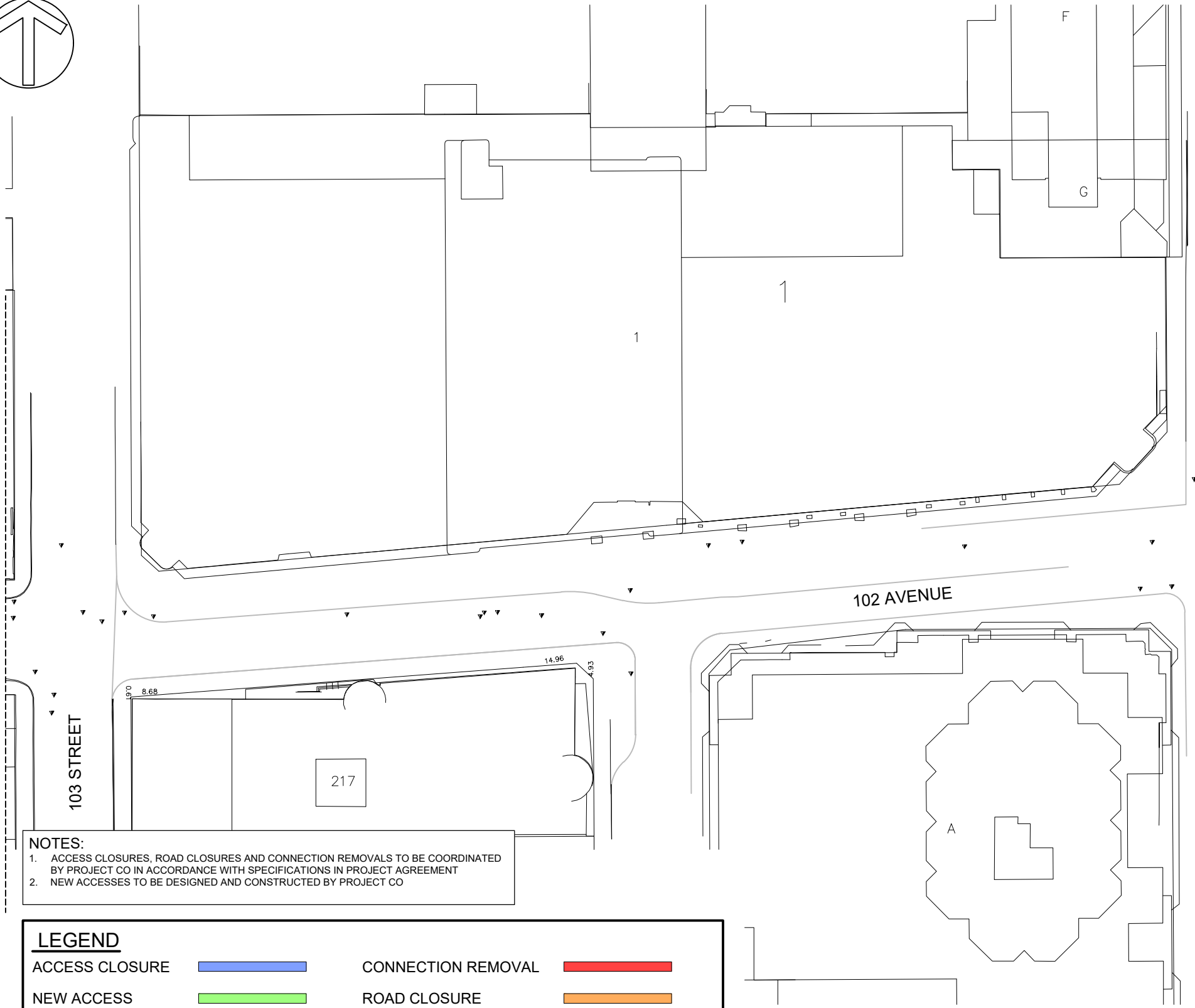

NOTES:
 1. ACCESS CLOSURES, ROAD CLOSURES AND CONNECTION REMOVALS TO BE COORDINATED BY PROJECT CO IN ACCORDANCE WITH SPECIFICATIONS IN PROJECT AGREEMENT
 2. NEW ACCESSSES TO BE DESIGNED AND CONSTRUCTED BY PROJECT CO

LEGEND			
ACCESS CLOSURE		CONNECTION REMOVAL	
NEW ACCESS		ROAD CLOSURE	

no.	description	date	checked
2	RFP V4	18-09-20	JM
1	RFP V3	07-23-20	JM
0	RFP	02-21-20	JM
revisions			

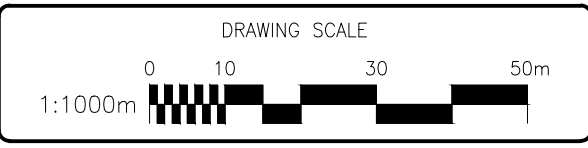

NOT FOR
CONSTRUCTION



ACCESS, ALLEY & ROAD CLOSURES

DRAWING NO: 5-3A-44

APPENDIX 5-3B

102 Avenue Grading Constraints Drawings

42194692.2

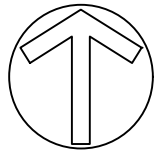

NOTES:

1. ELEVATIONS SHOWN WERE SURVEYED BETWEEN 2018 - 2019. SURVEY ELEVATIONS NOT TO BE RELIED UPON BEYOND DEVELOPMENT OF ITP RESPONSE.
2. PROJECT Co IS RESPONSIBLE TO CONFIRM ALL ELEVATIONS SHOWN ON THESE PLANS PRIOR TO DETAILED DESIGN.
3. POINTS IDENTIFIED WITH AN UNKNOWN ELEVATION WERE NOT SURVEYED, OR HAVE NOT YET BEEN INCLUDED AS PART OF THE PRELIMINARY ENGINEERING DESIGN. THEY HAVE BEEN IDENTIFIED FOR INFORMATION.
4. INFORMATION SHOWN ONLY REFLECTS CONSTRAINTS WHICH ARE IDENTIFIED IN THE PROJECT AGREEMENT SCHEDULE 5 PART 3-2.11.11. THERE MAY BE OTHER INFORMATION THAT REQUIRES FURTHER CONSIDERATIONS DURING DETAILED DESIGN.
5. ADJUSTMENTS TO THE VAULT CORNERS SHOWN, WILL NOT BE PERMITTED. MINOR ADJUSTMENTS TO VAULT MANHOLE RIMS MAY BE CONSIDERED DURING DETAILED DESIGN.
6. SOME UTILITIES ARE UNDER CONSTRUCTION AS PART OF EARLY WORKS. PROJECT Co SHALL OBTAIN AS-BUILTS AS PART OF PROJECT Co SURVEY CONFIRMATION OR DURING DETAILED DESIGN.

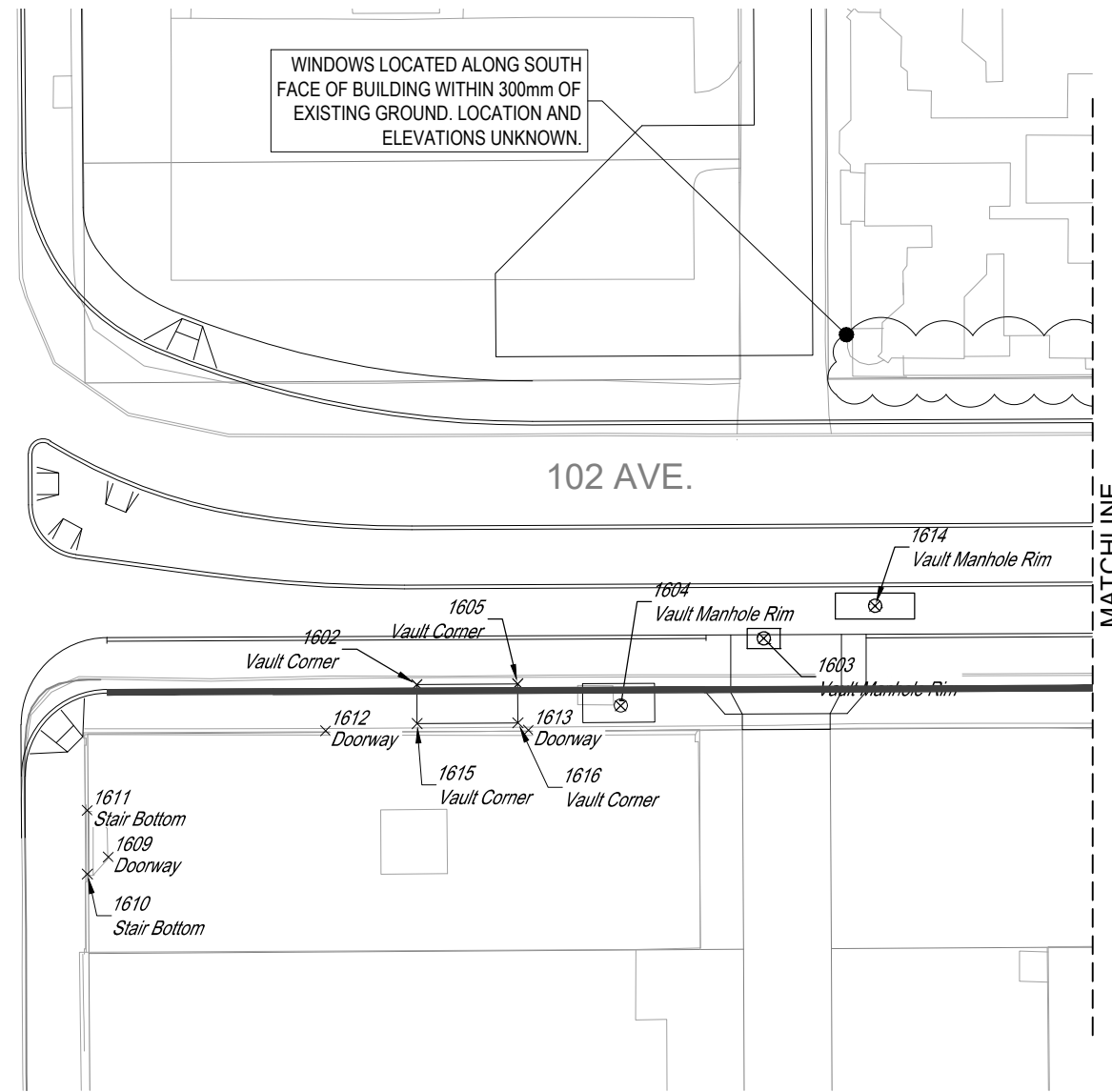
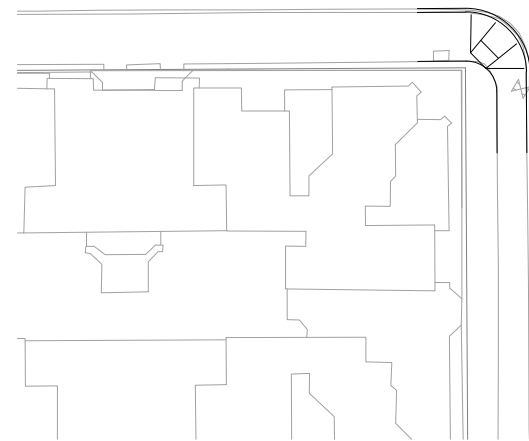
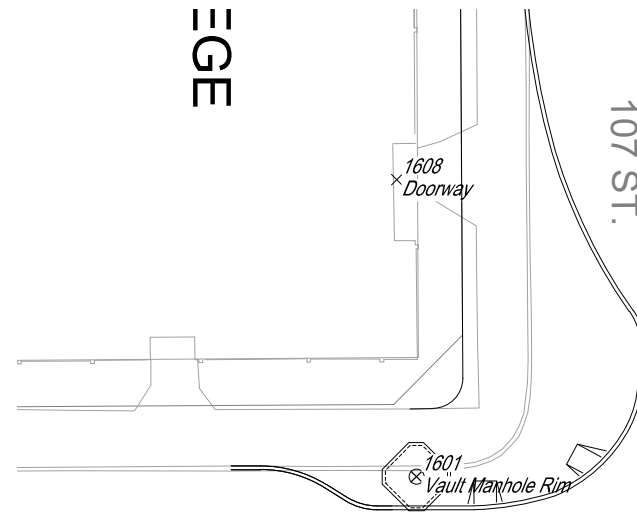

MATCHLINE
SEE DRAWING 5-3B-02

VALLEY LINE WEST LRT

TKL005 / September 11, 2020 / G:\PROJECTS\40001480014854_VALLEY_LINE_LRT_WEST_DESIGN_DE02_CADD\20_DRAFTING\2300_ROADWAYS\07_102 AVENUE GRADING EXHIBITS_PA_APPENDIX 5-B\VLW_APPENDIX 5B_102 AVE PLANS.DWG

no.	description	date	checked
3	RFP V4	18-09-20	JM
2	RFP V3	23-07-20	JM
1	RFP V2	29-05-20	JM
0	RFP	30-04-20	JM
revisions			

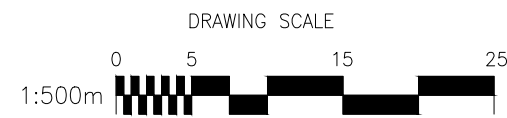

NOT FOR
CONSTRUCTION



APPENDIX 5-3B
102 AVENUE GRADING CONTSTRAINTS

DRAWING NO: 5-3B-01

TKL005 / September 11, 2020 / G:\PROJECTS\140001480014854_VALLEY_LINE_LRT_WEST_DESIGN_OE102_CADD\20_DRAFTING\2300_ROADWAYS\07_102 AVENUE GRADING EXHIBITS_PA APPENDIX 5-B\VLW_APPENDIX 5B_102 AVE PLANS.DWG

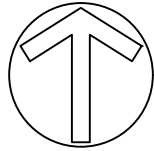

WINDOWS LOCATED ALONG SOUTH FACE OF BUILDING WITHIN 300mm OF EXISTING GROUND. LOCATION AND ELEVATIONS UNKNOWN.

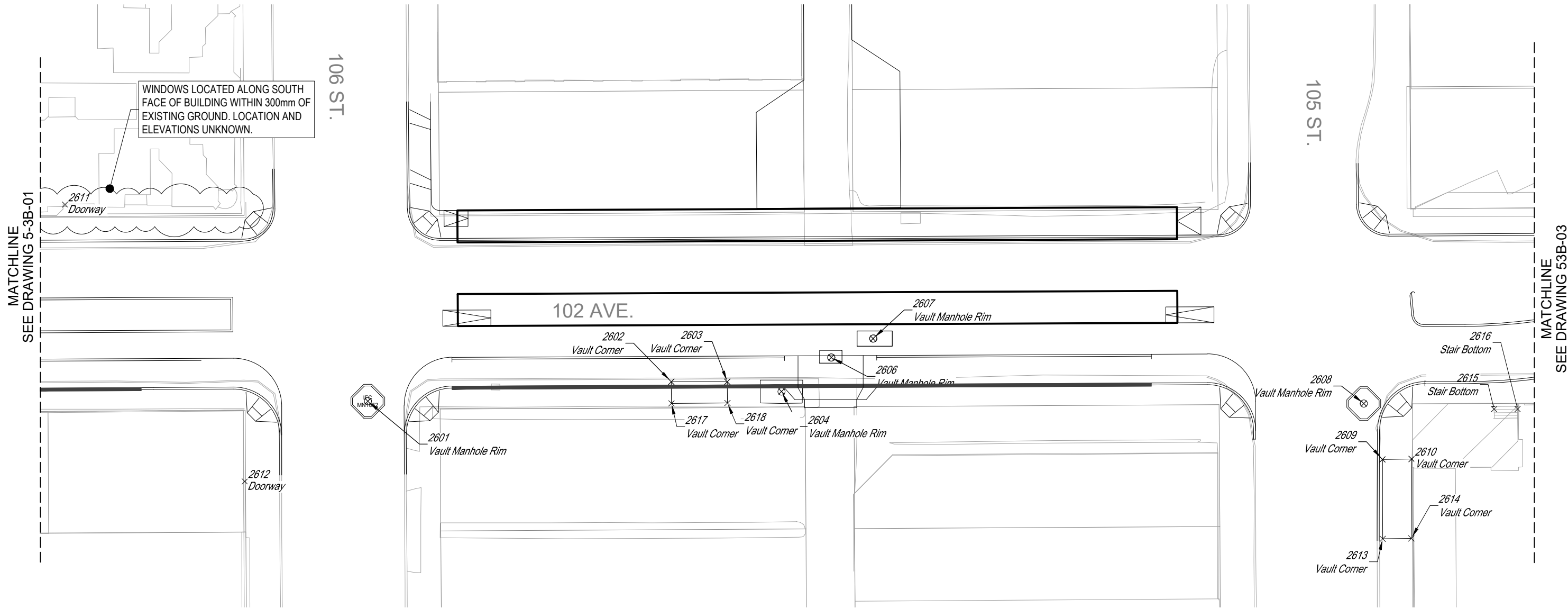

NOTES:

1. ELEVATIONS SHOWN WERE SURVEYED BETWEEN 2018 - 2019. SURVEY ELEVATIONS NOT TO BE RELIED UPON BEYOND DEVELOPMENT OF ITP RESPONSE.
2. PROJECT Co IS RESPONSIBLE TO CONFIRM ALL ELEVATIONS SHOWN ON THESE PLANS PRIOR TO DETAILED DESIGN.
3. POINTS IDENTIFIED WITH AN UNKNOWN ELEVATION WERE NOT SURVEYED, OR HAVE NOT YET BEEN INCLUDED AS PART OF THE PRELIMINARY ENGINEERING DESIGN. THEY HAVE BEEN IDENTIFIED FOR INFORMATION.
4. INFORMATION SHOWN ONLY REFLECTS CONSTRAINTS WHICH ARE IDENTIFIED IN THE PROJECT AGREEMENT SCHEDULE 5 PART 3-2.11.11. THERE MAY BE OTHER INFORMATION THAT REQUIRES FURTHER CONSIDERATIONS DURING DETAILED DESIGN
5. ADJUSTMENTS TO THE VAULT CORNERS SHOWN, WILL NOT BE PERMITTED. MINOR ADJUSTMENTS TO VAULT MANHOLE RIMS MAY BE CONSIDERED DURING DETAILED DESIGN.
6. SOME UTILITIES ARE UNDER CONSTRUCTION AS PART OF EARLY WORKS. PROJECT Co SHALL OBTAIN AS-BUILTS AS PART OF PROJECT Co SURVEY CONFIRMATION OR DURING DETAILED DESIGN.

no.	description	date	checked
3	RFP V4	18-09-20	JM
2	RFP V3	23-07-20	JM
1	RFP V2	29-05-20	JM
0	RFP	30-04-20	JM
revisions			

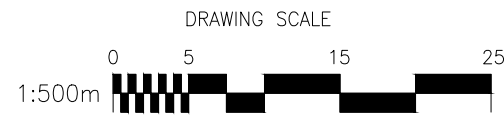

NOT FOR
CONSTRUCTION



APPENDIX 5-3B
102 AVENUE GRADING CONTSTRAINTS

DRAWING NO: 5-3B-02

VALLEY LINE WEST LRT

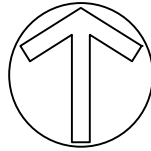

MATCHLINE
SEE DRAWING 5-3B-02

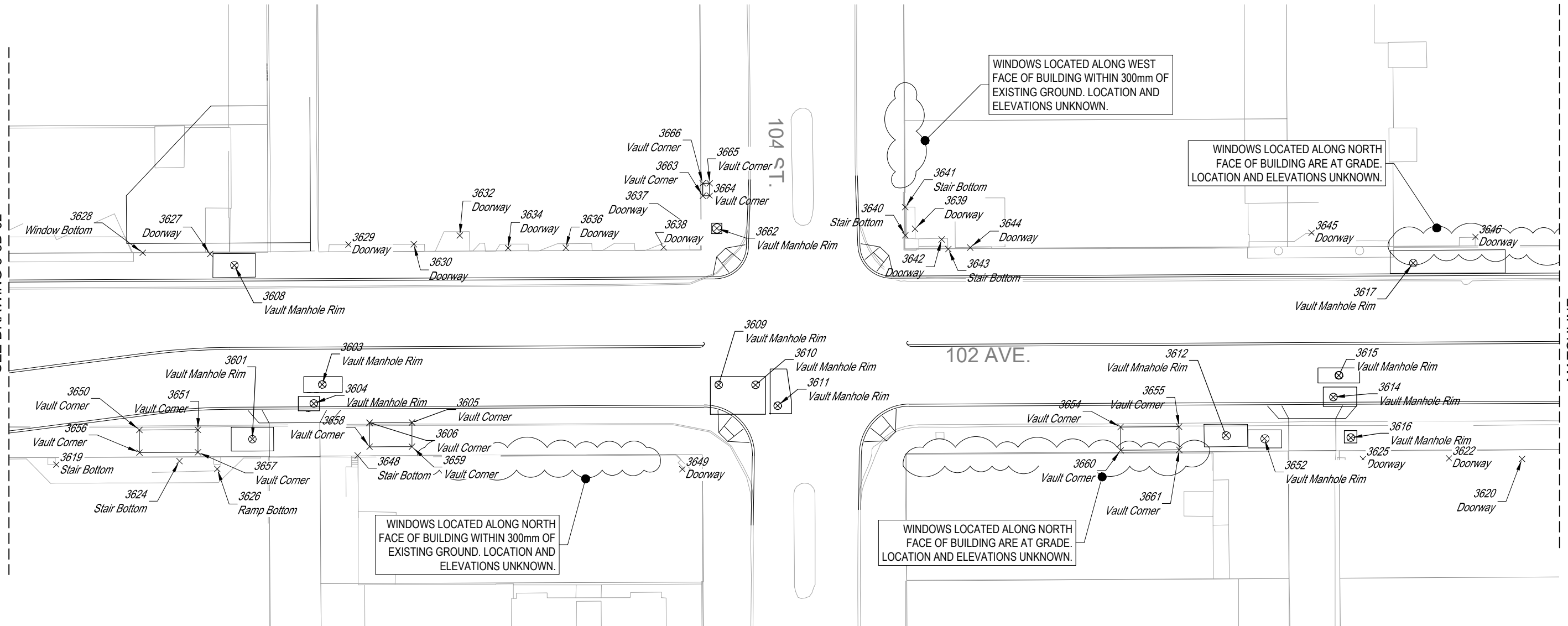

MATCHLINE
SEE DRAWING 5-3B-04

VALLEY LINE WEST LRT

NOTES:

- ELEVATIONS SHOWN WERE SURVEYED BETWEEN 2018 - 2019. SURVEY ELEVATIONS NOT TO BE RELIED UPON BEYOND DEVELOPMENT OF ITP RESPONSE.
- PROJECT Co IS RESPONSIBLE TO CONFIRM ALL ELEVATIONS SHOWN ON THESE PLANS PRIOR TO DETAILED DESIGN.
- POINTS IDENTIFIED WITH AN UNKNOWN ELEVATION WERE NOT SURVEYED, OR HAVE NOT YET BEEN INCLUDED AS PART OF THE PRELIMINARY ENGINEERING DESIGN. THEY HAVE BEEN IDENTIFIED FOR INFORMATION.
- INFORMATION SHOWN ONLY REFLECTS CONSTRAINTS WHICH ARE IDENTIFIED IN THE PROJECT AGREEMENT SCHEDULE 5 PART 3-2.11.11. THERE MAY BE OTHER INFORMATION THAT REQUIRES FURTHER CONSIDERATIONS DURING DETAILED DESIGN
- ADJUSTMENTS TO THE VAULT CORNERS SHOWN, WILL NOT BE PERMITTED. MINOR ADJUSTMENTS TO VAULT MANHOLE RIMS MAY BE CONSIDERED DURING DETAILED DESIGN.
- SOME UTILITIES ARE UNDER CONSTRUCTION AS PART OF EARLY WORKS. PROJECT Co SHALL OBTAIN AS-BUILTS AS PART OF PROJECT Co SURVEY CONFIRMATION OR DURING DETAILED DESIGN.

no.	description	date	checked
3	RFP V4	18-09-20	JM
2	RFP V3	23-07-20	JM
1	RFP V2	29-05-20	JM
0	RFP	30-04-20	JM
revisions			

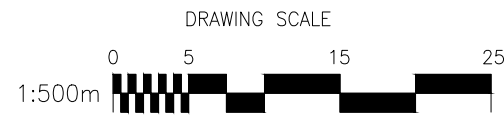

NOT FOR
CONSTRUCTION

AECOM
Prime Consultant

Edmonton

HATCH

DIALOG

ISL Engineering

M M
MOTT
MACDONALD

APPENDIX 5-3B
102 AVENUE GRADING CONTSTRAINTS

DRAWING NO: 5-3B-03

TKL005 / September 11, 2020 / G:\PROJECTS\140001480014854_VALLEY_LINE_LRT_WEST_DESIGN_OE102_CADD\20_DRAFTING\2300_ROADWAYS\07_102 AVENUE GRADING EXHIBITS_PA APPENDIX 5-B\VLW_APPENDIX 5B_102 AVE PLANS.DWG

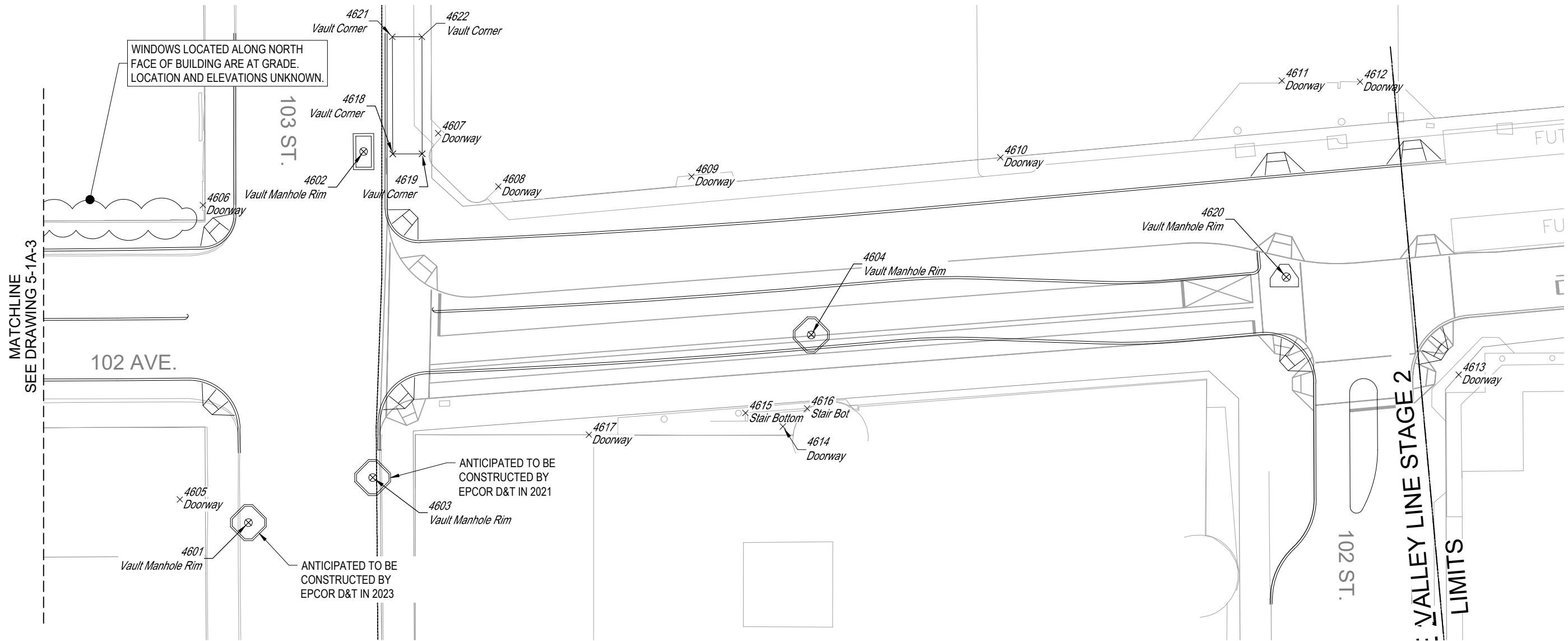
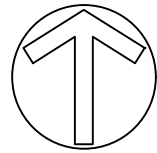

NOTES:

1. ELEVATIONS SHOWN WERE SURVEYED BETWEEN 2018 - 2019. SURVEY ELEVATIONS NOT TO BE RELIED UPON BEYOND DEVELOPMENT OF ITP RESPONSE.
2. PROJECT Co IS RESPONSIBLE TO CONFIRM ALL ELEVATIONS SHOWN ON THESE PLANS PRIOR TO DETAILED DESIGN.
3. POINTS IDENTIFIED WITH AN UNKNOWN ELEVATION WERE NOT SURVEYED, OR HAVE NOT YET BEEN INCLUDED AS PART OF THE PRELIMINARY ENGINEERING DESIGN. THEY HAVE BEEN IDENTIFIED FOR INFORMATION.
4. INFORMATION SHOWN ONLY REFLECTS CONSTRAINTS WHICH ARE IDENTIFIED IN THE PROJECT AGREEMENT SCHEDULE 5 PART 3-2.11.11. THERE MAY BE OTHER INFORMATION THAT REQUIRES FURTHER CONSIDERATIONS DURING DETAILED DESIGN
5. ADJUSTMENTS TO THE VAULT CORNERS SHOWN, WILL NOT BE PERMITTED. MINOR ADJUSTMENTS TO VAULT MANHOLE RIMS MAY BE CONSIDERED DURING DETAILED DESIGN.
6. SOME UTILITIES ARE UNDER CONSTRUCTION AS PART OF EARLY WORKS. PROJECT Co SHALL OBTAIN AS-BUILTS AS PART OF PROJECT Co SURVEY CONFIRMATION OR DURING DETAILED DESIGN.
7. REFER TO CURRENT VALLEY LINE SOUTH EAST REFERENCE DESIGN (DETAILED DESIGN DRAWINGS - ISSUED FOR CONSTRUCTION) FOR INTERIM DESIGN INFORMATION BETWEEN 102 STREET AND 103 STREET.

no.	description	date	checked
3	RFP V4	18-09-20	JM
2	RFP V3	23-07-20	JM
1	RFP V2	29-05-20	JM
0	RFP	30-04-20	JM
revisions			

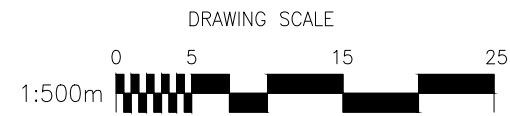

NOT FOR CONSTRUCTION

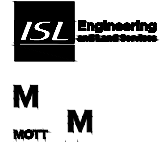

APPENDIX 5-3B
102 AVENUE GRADING CONTSTRAINTS

DRAWING NO: 5-3B-04

TKLOOS / September 11, 2020 / G:\PROJECTS\40001480\14854_VALLEY_LINE_LRT_WEST_DESIGN_DE02_CADD\3D0_DRAFTING\3D00_ROADWAYS\07_102 AVENUE GRADING EXHIBITS_PA_APPENDIX 5-B\1W_APPENDIX 5-B\1W_PLANS.DWG

102 STREET CRITICAL ELEVATION POINTS

POINT NUMBER	NORTHING	EASTING	ELEVATION	DESCRIPTION
DRAWING NO: 5-3B-01				
1601.000000	5935708.730	32818.698	Unknown	Vault Manhole Rim
1602.000000	5935692.741	32869.226	665.997	Vault Corner
1603.000000	5935695.947	32893.296	666.117	Vault Manhole Rim
1604.000000	5935691.280	32883.374	666.197	Vault Manhole Rim
1605.000000	5935692.787	32876.228	666.087	Vault Corner
1608.000000	5935728.362	32817.396	665.692	Doorway
1609.000000	5935680.783	32847.820	666.418	Doorway
1610.000000	5935679.597	32846.361	665.926	Stair Bottom
1611.000000	5935684.014	32846.360	665.834	Stair Bottom
1612.000000	5935689.535	32862.893	665.952	Doorway
1613.000000	5935689.579	32876.978	666.047	Doorway
1614.000000	5935698.199	32901.027	666.229	Vault Manhole Rim
1615.000000	5935690.040	32869.244	666.031	Vault Corner
1616.000000	5935690.086	32876.245	666.121	Vault Corner
DRAWING NO: 5-3B-02				
2601	5935691.056	32958.982	666.670	Vault Manhole Rim
2602	5935693.491	32996.936	666.949	Vault Corner
2603	5935693.491	33003.938	666.991	Vault Corner
2604	5935692.273	33010.722	Unknown	Vault Manhole Rim
2606	5935696.526	33016.940	666.897	Vault Manhole Rim
2607	5935698.887	33022.179	666.974	Vault Manhole Rim
2608	5935690.769	33083.559	667.128	Vault Manhole Rim
2609	5935683.785	33085.888	667.228	Vault Corner
2610	5935683.844	33089.532	667.332	Vault Corner
2611	5935715.638	32921.101	666.469	Doorway
2612	5935681.041	32943.597	666.724	Doorway
2613	5935673.865	33085.916	Unknown	Vault Corner
2614	5935673.917	33089.497	Unknown	Vault Corner
2615	5935690.069	33099.845	667.504	Stair Bottom
2616	5935690.083	33102.788	667.515	Stair Bottom
2617	5935690.791	32996.954	666.989	Vault Corner
2618	5935690.837	33003.955	667.031	Vault Corner

102 STREET CRITICAL ELEVATION POINTS

POINT NUMBER	NORTHING	EASTING	ELEVATION	DESCRIPTION
DRAWING NO: 5-3B-03				
3601	5935692.985	33133.319	Unknown	Vault Manhole Rim
3603	5935699.514	33141.669	667.786	Vault Manhole Rim
3604	5935697.247	33140.660	667.832	Vault Manhole Rim
3605	5935694.981	33152.410	667.838	Vault Corner
3606	5935694.944	33147.335	667.803	Vault Corner
3608	5935713.772	33131.159	667.649	Vault Manhole Rim
3609	5935699.470	33189.083	668.040	Vault Manhole Rim
3610	5935699.470	33193.483	668.097	Vault Manhole Rim
3611	5935696.988	33196.137	668.113	Vault Manhole Rim
3612	5935693.450	33249.741	668.364	Vault Manhole Rim
3614	5935698.019	33262.583	668.467	Vault Manhole Rim
3615	5935700.614	33263.248	668.515	Vault Manhole Rim
3616	5935693.164	33264.675	668.565	Vault Manhole Rim
3617	5935714.031	33272.139	668.472	Vault Manhole Rim
3619	5935689.939	33109.882	667.563	Stair Bottom
3620	5935690.619	33285.167	668.500	Doorway
3622	5935690.694	33276.431	668.500	Doorway
3624	5935690.367	33124.598	667.894	Stair Bottom
3625	5935690.619	33266.134	668.500	Doorway
3626	5935689.422	33129.120	667.943	Ramp Bottom
3627	5935715.128	33128.266	667.667	Doorway
3628	5935715.271	33120.209	Unknown	Window Bottom
3629	5935716.253	33144.816	667.837	Doorway
3630	5935716.299	33152.633	667.836	Doorway
3632	5935717.341	33158.128	667.952	Doorway
3634	5935715.840	33163.912	668.087	Doorway
3636	5935715.877	33170.802	668.097	Doorway
3637	5935718.071	33186.135	668.102	Doorway
3638	5935715.926	33182.514	668.102	Doorway
3639	5935718.136	33212.570	668.521	Doorway
3640	5935717.364	33211.405	668.102	Stair Bottom
3641	5935720.732	33211.390	668.107	Stair Bottom
3642	5935716.872	33215.750	668.518	Doorway
3643	5935715.720	33216.550	668.135	Stair Bottom
3644	5935715.896	33219.165	668.157	Doorway
3645	5935717.659	33259.992	668.494	Doorway
3646	5935717.181	33279.593	668.503	Doorway
3648	5935691.031	33145.916	667.879	Stair Bottom
3649	5935689.391	33184.745	668.122	Doorway
3650	5935694.087	33119.803	667.651	Vault Corner
3651	5935694.116	33126.804	667.798	Vault Corner
3652	5935693.053	33254.345	668.437	Vault Manhole Rim
3654	5935694.441	33237.143	668.292	Vault Corner
3655	5935694.483	33244.145	668.357	Vault Corner
3656	5935691.387	33119.814	667.735	Vault Corner

102 STREET CRITICAL ELEVATION POINTS

POINT NUMBER	NORTHING	EASTING	ELEVATION	DESCRIPTION
DRAWING NO: 5-3B-03				
3657	5935691.416	33126.816	667.880	Vault Corner
3658	5935692.077	33147.337	667.887	Vault Corner
3659	5935692.089	33152.404	667.851	Vault Corner
3660	5935691.663	33237.160	668.309	Vault Corner
3661	5935691.706	33244.161	668.404	Vault Corner
3662	5935718.193	33188.870	668.078	Vault Manhole Rim
3663	5935722.090	33187.183	668.057	Vault Corner
3664	5935722.094	33188.021	Unknown	Vault Corner
3665	5935723.593	33188.014	668.022	Vault Corner
3666	5935723.589	33187.176	668.030	Vault Corner

102 STREET CRITICAL ELEVATION POINTS

POINT NUMBER	NORTHING	EASTING	ELEVATION	DESCRIPTION
DRAWING NO: 5-3B-04				
4601	5935680.590	33314.118	Unknown	Vault Manhole Rim
4602	5935724.337	33327.708	Unknown	Vault Manhole Rim
4603	5935685.901	33328.787	Unknown	Vault Manhole Rim
4604	5935702.748	33380.553	Unknown	Vault Manhole Rim
4605	5935683.320	33306.039	668.500	Doorway
4606	5935718.025	33308.755	668.663	Doorway
4607	5935726.507	33336.524	668.549	Doorway
4608	5935720.227	33343.630	668.575	Doorway
4609	5935721.406	33366.423	668.773	Doorway
4610	5935723.652	33402.884	Unknown	Doorway
4611	5935732.722	33436.092	Unknown	Doorway
4612	5935732.578	33445.332	Unknown	Doorway
4613	5935698.033	33456.970	Unknown	Doorway
4614	5935691.925	33377.200	Unknown	Doorway
4615	5935693.526	33372.786	Unknown	Stair Bottom
4616	5935694.053	33380.070	Unknown	Stair Bot
4617	5935690.955	33354.318	Unknown	Doorway
4618	5935724.071	33331.160	Unknown	Vault Corner
4619	5935724.080	33334.618	Unknown	Vault Corner
4620	5935709.543	33436.614	Unknown	Vault Manhole Rim
4621	5935737.885	33331.099	Unknown	Vault Corner
4622	5935737.886	33334.591	Unknown	Vault Corner

VALLEY LINE WEST LRT

no.	description	date	checked
3	RFP V4	18-09-20	JM
2	RFP V3	23-07-20	JM
1	RFP V2	29-05-20	JM
0	RFP	30-04-20	JM
revisions			

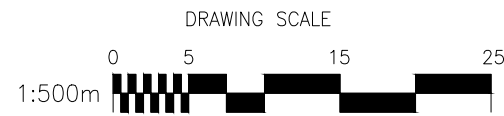

NOT FOR
CONSTRUCTION



APPENDIX 5-3B
102 AVENUE GRADING CONTSTRAINTS

DRAWING NO: 5-3B-05