

COMPLETE STREETS DESIGN AND CONSTRUCTION STANDARDS 2-03: DETAILS

City of Edmonton

Version 06
COE-IM-GUIDE-0048

Date of Issue: November 2025



DISCLAIMER

This volume was developed for establishing standards and guidelines for the City of Edmonton's expectations in the design and construction of transportation infrastructure. Care has been taken to confirm the accuracy of the information contained herein. The views expressed herein do not necessarily represent those of any individual contributor. Transportation and related asset design continually evolves, and practices change and improve over time, so it is necessary to regularly consult relevant technical standards, codes, and other publications rather than relying on this publication exclusively. The City of Edmonton, authors, and members of the review committee, want to convey that this document does not constitute a project-specific design. As such, no part of this guideline alleviates the responsibility of the professionals retained to design and construct specific projects from taking full responsibility and authenticating their designs as required in accordance with AALA, APEGA, AAA, Alberta Building Code, and any other statutory or safety requirements.

Any Standard Drawings, Details, or specifications are provided to convey the City's typically ideal general arrangement and requirements. Representations may not be to scale, they may be substantially schematic in nature and/or require further elaboration and development. As such those documents are not suitable for integration into a specific implementation without review and modification and are only intended for use by a competent designer exercising professional judgement. The designer shall modify and supplement as necessary to provide a complete, properly functioning design that conforms in all respects to the City's functional requirements. When actualized in a particular implementation it is the designer's responsibility to ensure the size, location, and spacing of all elements, and all components/specifications, are suitable and safe for the use and location intended, and any applicable code, legislative, and authority requirements are adhered to. In addition, any accessibility, operational and maintenance requirements must be met. Deviations from the represented nominal design parameters, questions of intent or accuracy, or any other apparent conflicts, shall be reconciled with an appropriate City representative. Finally, when employing any aspect of these documents, the ultimately responsible professional designer shall remove any authentication of the original author(s), note any provenance as appropriate, and apply their own authentication as required.

Important Note:

Printed or downloaded copies of this document are not controlled and may not be the current version.

AUTHENTICATION TABLE

<p>Complete Streets Standard Drawings Section 1000 - Utility Cut Restoration (All) Section 2000 - Cross-Sections (All) Section 3000 - Design Details (All) Section 4000 - Transit Details (All) Section 5000 - Construction Details (All) Section 6000/7000 Miscellaneous Details (All)</p>	<p>Matthew Ivany, P.Eng. General Supervisor, Transportation Planning And Design</p>	
<p>Permit to Practice - Entire Document</p> <p>Complete Streets Design and Construction Standards (All)</p> <p>Complete Streets Construction Specifications (All)</p> <p>Complete Streets Standard Drawings (All)</p>	<p>Natalie Lazurko, P. Eng Director, Transportation Planning And Design</p>	

CHANGE HISTORY - STANDARD DETAILS

<i>Version</i>	<i>DWG</i>	<i>Drawing Name</i>	<i>Revision</i>	<i>Date</i>
06	1000	PAVEMENT RESTORATION AFTER UTILITY CUT	Added driving lane restoration limits	Nov-25
06	1020	TRANSVERSE CUT RESTORATION ARTERIAL ROAD	Removed 3-year no cut	Nov-25
06	1021	TRANSVERSE CUT RESTORATION 14.5m COLLECTOR ROAD	Removed 3-year no cut	Nov-25
06	1022	TRANSVERSE CUT RESTORATION 11.5m COLLECTOR ROAD	Removed 3-year no cut	Nov-25
06	1023	TRANSVERSE CUT RESTORATION LOCAL INDUSTRIAL ROAD	Removed 3-year no cut	Nov-25
06	1024	TRANSVERSE CUT RESTORATION LOCAL RESIDENTIAL ROAD	Removed 3-year no cut	Nov-25
06	1025	TRANSVERSE CUT RESTORATION ALLEYS	Removed reference to 3-year no cut	Nov-25
06	1030	CURB AND GUTTER / MONOWALK REPLACEMENT SAWCUT DETAILS	Revised wick drain location and label to specify replacement of wick drain.	Nov-25
06	2000	TYPICAL BERM SECTION	Added dimensions and additional clarifications	Nov-25
06	2020	STAGED ARTERIAL GRADING REQUIREMENTS	Revised topsoil requirements to reference Volume 5: Landscape	Nov-25
06	2030	RESIDENTIAL SERVICE ROAD	Revised minimum service road width and notes.	Nov-25
06	2040	4.00m RESIDENTIAL ALLEY	Revised dimensioning for underground utilities.	Nov-25
06	2041	6.00m COMMERCIAL ALLEY	Revised text labels to remove overlap.	Nov-25
06	2042	RESIDENTIAL REVERSE HOUSING ALLEY - 7.50m ROW	Substantially updated to address utility placement and dimensions.	Nov-25
06	2043	REVERSE HOUSING ALLEY WITH PARKING - 9.50m ROW	Substantially updated to address utility placement and dimensions.	Nov-25
06	2044	REVERSE HOUSING ALLEY WITH PARKING AND WALK - 14.00m ROW	New drawing	Nov-25
06	2045	RESIDENTIAL SHARED ALLEY - 6.00m ROW	New drawing	Nov-25
06	2046	COMMERCIAL SHARED ALLEY - 8.00m - 10.00m ROW	New drawing	Nov-25
06	2050	9.00m RURAL LOCAL / COLLECTOR ROADWAY	Revised sideslopes and ditch bottom dimensions	Nov-25
06	2120	8.00m URBAN LOCAL RESIDENTIAL (MONOWALK BOTH SIDES) - 16.00m ROW	Removed and replaced with new drawings 2220 and 2221	Nov-25
06	2125	8.00m STREET ORIENTED RESIDENTIAL LOCAL - 16.00m ROW	Removed and replaced with new drawings 2220 and 2221	Nov-25
06	2200	9.00m URBAN LOCAL RESIDENTIAL (MONOWALK) - 17.00m ROW	Removed and replaced with new drawings 2210 and 2211	Nov-25
06	2210	9.00m STREET ORIENTED RESIDENTIAL LOCAL - 17.00m ROW	Removed and replaced with new drawings 2210 and 2211	Nov-25
06	2210	9.00m LOCAL RESIDENTIAL (BOULEVARD WALK) - 17.00m ROW	New drawing	Nov-25

Version	DWG	Drawing Name	Revision	Date
06	2211	9.00m LOCAL RESIDENTIAL (ALTERNATIVE BOULEVARDS) - 17.00m ROW	New drawing	Nov-25
06	2220	8.00m LOCAL RESIDENTIAL (BOULEVARD WALK) - 16.00m ROW	New drawing	Nov-25
06	2221	8.00m LOCAL RESIDENTIAL (ALTERNATIVE BOULEVARDS) - 16.00m ROW	New drawing	Nov-25
06	2230	8.00m LOCAL RESIDENTIAL (BOULEVARD WALK) - 17.00m ROW	New drawing	Nov-25
06	2231	8.00m LOCAL RESIDENTIAL (ALTERNATIVE BOULEVARDS) - 17.00m ROW	New drawing	Nov-25
06	2240	9.00m LOCAL RESIDENTIAL (BOULEVARD WALK) - 18.00m ROW	New drawing	Nov-25
06	2241	9.00m LOCAL RESIDENTIAL (ALTERNATIVE BOULEVARDS) - 18.00m ROW	New drawing	Nov-25
06	2250	9.00m OPEN SPACE LOCAL RESIDENTIAL (BOULEVARD WALK AND PATHWAY) - 17.00m ROW	New drawing	Nov-25
06	2255	9.00 ENHANCED LOCAL WITH PATHWAY (PARKING ONE OR BOTH SIDES) - 19.30m ROW	New drawing	Nov-25
06	2290 A	LOCAL ROAD BOULEVARD DETAILS - 4.00m BLVD/1.800m BLVD WALK/2.0m GAS EASEMENT	New drawing	Nov-25
06	2290 B	LOCAL ROAD BOULEVARD DETAILS - 4.00m BLVD/1.800m BLVD WALK/2.7m MULTI PARTY EASEMENT	New drawing	Nov-25
06	2291 A	LOCAL ROAD BOULEVARD DETAILS - 4.00m BLVD/2.100m MONO WALK/2.0m GAS EASEMENT	New drawing	Nov-25
06	2291 B	LOCAL ROAD BOULEVARD DETAILS - 4.00m BLVD/2.100m MONO WALK/2.7m MULTI PARTY EASEMENT	New drawing	Nov-25
06	2292 A	LOCAL ROAD BOULEVARD DETAILS - 4.00m BLVD/2.175m MONO WALK/2.0m GAS EASEMENT	New drawing	Nov-25
06	2292 B	LOCAL ROAD BOULEVARD DETAILS - 4.00m BLVD/2.175m MONO WALK/2.7m MULTI PARTY EASEMENT	New drawing	Nov-25
06	2293 A	LOCAL ROAD BOULEVARD DETAILS - 4.15m BLVD/1.800m BLVD WALK/2.0m GAS EASEMENT	New drawing	Nov-25
06	2293 B	LOCAL ROAD BOULEVARD DETAILS - 4.15m BLVD/1.800m BLVD WALK/2.7m MULTI PARTY EASEMENT	New drawing	Nov-25
06	2294 A	LOCAL ROAD BOULEVARD DETAILS - 4.15m BLVD/2.100m MONO WALK/2.0m GAS EASEMENT	New drawing	Nov-25
06	2294 B	LOCAL ROAD BOULEVARD DETAILS - 4.15m BLVD/2.100m MONO WALK/2.7m MULTI PARTY EASEMENT	New drawing	Nov-25
06	2295 A	LOCAL ROAD BOULEVARD DETAILS - 4.15m BLVD/2.175m MONO WALK/2.0m GAS EASEMENT	New drawing	Nov-25
06	2295 B	LOCAL ROAD BOULEVARD DETAILS - 4.15m BLVD/2.175m MONO WALK/2.7m MULTI PARTY EASEMENT	New drawing	Nov-25

Version	DWG	Drawing Name	Revision	Date
06	2296 A	LOCAL ROAD BOULEVARD DETAILS - 4.50m BLVD/1.800m BLVD WALK/2.0m GAS EASEMENT	New drawing	Nov-25
06	2296 B	LOCAL ROAD BOULEVARD DETAILS - 4.50m BLVD/1.800m BLVD WALK/2.7m MULTI PARTY EASEMENT	New drawing	Nov-25
06	2297 A	LOCAL ROAD BOULEVARD DETAILS - 4.50m BLVD/2.175m MONO WALK/2.0m GAS EASEMENT	New drawing	Nov-25
06	2297 B	LOCAL ROAD BOULEVARD DETAILS - 4.50m BLVD/2.175m MONO WALK/2.7m MULTI PARTY EASEMENT	New drawing	Nov-25
06	2300	11.50m INDUSTRIAL LOCAL (MONOWALK) - 20.00m ROW	Revised notes.	Nov-25
06	2310	11.50m INDUSTRIAL LOCAL (BOULEVARD WALK) - 20.00 ROW	Revised notes. Revised streetlight / power offset.	Nov-25
06	2320	11.50m STREET ORIENTED RESIDENTIAL COLLECTOR (NOT ON BIKE NETWORK) - 20.00m ROW	Removed and replaced with new drawings: detail 2321 and 2327	Nov-25
06	2321	9.30m COLLECTOR (NOT ON BIKE NETWORK) - 18.00m ROW	Substantially updated	Nov-25
06	2322	10.70m NON-STREET ORIENTED RESIDENTIAL COLLECTOR (ON BIKE NETWORK) - 19.00m ROW	Drawing removed	Nov-25
06	2323	11.30m NON-STREET ORIENTED RESIDENTIAL OR COMMERCIAL/MIXED USE COLLECTOR (ON BIKE NETWORK) - 19.60m ROW	Drawing removed	Nov-25
06	2324	13.75m STREET ORIENTED RESIDENTIAL COLLECTOR (ON BIKE NETWORK) - 22.0m ROW	Drawing removed	Nov-25
06	2325	9.30m NON-STREET ORIENTED RESIDENTIAL OR COMMERCIAL / MIXED USE COLLECTOR (ON BIKE NETWORK) - 22.0m ROW	Added note regarding utility offsets to follow Volume 1. Revised streetlight / tree offset.	Nov-25
06	2326	12.00m STREET ORIENTED COMMERCIAL/MIXED USE COLLECTOR (NOT ON BIKE NETWORK) - 22.00m ROW	Drawing removed	Nov-25
06	2327	11.50m STREET ORIENTED RESIDENTIAL COLLECTOR (ON BIKE NETWORK) - 21.5m ROW	Drawing removed	Nov-25
06	2328	11.50m SCHOOL SITE COLLECTOR (NOT ON BIKE NETWORK) - 20.0m ROW	Drawing removed	Nov-25
06	2330	9.30m BASE COLLECTOR - 20.00m ROW	New drawing	Nov-25
06	2331	ALTERNATE COLLECTOR BOULEVARDS A AND B	New drawing	Nov-25
06	2332	ALTERNATE COLLECTOR BOULEVARDS C AND D (SCHOOL SITE)	New drawing	Nov-25
06	2333	ALTERNATE COLLECTOR BOULEVARDS E (OPEN SPACE)	New drawing	Nov-25
06	2341	16.30m STREET ORIENTED RESIDENTIAL COLLECTOR (ON BIKE NETWORK) - 24.00m ROW	Drawing removed	Nov-25
06	2342	16.80m STREET ORIENTED COMMERCIAL MIXED-USE COLLECTOR (ON BIKE NETWORK) - 26.60m ROW	Drawing removed	Nov-25
06	2345	11.50m COLLECTOR WITH PATHWAY - 24.00m ROW	New drawing	Nov-25

Version	DWG	Drawing Name	Revision	Date
06	2346	11.50m COLLECTOR WITH BIKE LANES - 27.70m ROW	New drawing	Nov-25
06	2410	13.70m URBAN COLLECTOR (BOULEVARD WALK) - 23.80m ROW	Drawing removed	Nov-25
06	2411	13.20m INDUSTRIAL COLLECTOR (SHARED PATHWAY) - 24.00m ROW	Revised notes and utility locations	Nov-25
06	2420	11.10m HYBRID INDUSTRIAL COLLECTOR (SHARED PATHWAY) - 30.55m ROW	Revised notes and utility locations	Nov-25
06	2421	9.50m HYBRID INDUSTRIAL LOCAL (BOULEVARD WALK) - 27.50m ROW	Drawing removed	Nov-25
06	2422	8.25m RETROFIT HYBRID INDUSTRIAL COLLECTOR (BOULEVARD WALK) - 20.00m ROW	New drawing	Nov-25
06	2430	9.00m RURAL INDUSTRIAL COLLECTOR - 42.90m ROW	Drawing removed	Nov-25
06	2431	9.00m RURAL INDUSTRIAL LOCAL - 38.60m ROW	Drawing removed	Nov-25
06	2500	5 LANE UNDIVIDED ARTERIAL - 37.00m ROW	Revised notes and utility locations	Nov-25
06	2510	FOUR LANE DIVIDED ARTERIAL - 37.00m ROW	Revised notes and utility locations	Nov-25
06	2510 A	FOUR LANE NON-STREET ORIENTED RESIDENTIAL DIVIDED ARTERIAL - 37.00m ROW - B	Drawing removed	Nov-25
06	2515	FOUR LANE STREET ORIENTED RESIDENTIAL DIVIDED ARTERIAL - 40.00m ROW	Drawing removed	Nov-25
06	2520	6 LANE URBAN DIVIDED ARTERIAL - 44.00m ROW	Revised notes and utility locations	Nov-25
06	2530	RURAL FIVE LANE INDUSTRIAL ARTERIAL (SHARED USE PATH) - 57.40m ROW	Drawing removed	Nov-25
06	2600	UTILITIES LOCATION PLAN WALKWAYS - 6.00m ROW	Added ROW dimension to drawing name.	Nov-25
06	3020	RURAL LOCAL ACCESS	Revised to add additional details on culvert installation, widths, surfacing structure.	Nov-25
06	3030	ALTERNATIVE ALLEY CORNER WIDENING IN LIEU OF 3.00m x 3.00m CORNER CUT	Drawing removed	Nov-25
06	3031	STANDARD ALLEY CORNER CUT (5.00m x 5.00m)	New drawing	Nov-25
06	3032	ALTERNATIVE ALLEY CORNER WIDENING IN LIEU OF 5.00m x 5.00m CORNER CUT	New drawing	Nov-25
06	3041	PUBLIC ALLEY TURN AROUND	New drawing	Nov-25
06	3041	PUBLIC ALLEY INTERSECTION	New drawing	Nov-25
06	3500	RESIDENTIAL CUL-DE-SAC (WITHOUT ISLAND)	Added requirement for sidewalks.	Nov-25
06	3510	RESIDENTIAL CUL-DE-SAC (CIRCULAR ISLAND)	Added offset from LOG to central island. Added requirement for sidewalks.	Nov-25
06	3520	RESIDENTIAL CUL-DE-SAC (CIRCULAR OFFSET ISLAND)	Added requirement for sidewalks.	Nov-25
06	3530	RESIDENTIAL EYEBROW (CIRCULAR ISLAND)	Revised drawing name and added requirement for sidewalks.	Nov-25

Version	DWG	Drawing Name	Revision	Date
06	3540	SIDEWALK REQUIREMENTS CUL-DE-SAC	Revised notes to align with Cul-de-Sac memorandum and new standards content.	Nov-25
06	3700	NEIGHBOURHOOD TRAFFIC CIRCLE 9m URBAN LOCAL x 9m URBAN LOCAL	Removed and replaced with new drawings	Nov-25
06	3710	MINI ROUNDABOUT 11.5m URBAN COLLECTOR x 11.5m URBAN COLLECTOR WITH SHARED PATHWAY AND ON-STREET BIKE LANE	Removed and replaced with new drawings	Nov-25
06	3720	MULTILANE ROUNDABOUT 13.9m URBAN COLLECTOR x 13.9m URBAN COLLECTOR	Removed and replaced with new drawings	Nov-25
06	3700	NEIGHBOURHOOD TRAFFIC CIRCLE	New drawing	Nov-25
06	3710	MINI ROUNDABOUT (WITHIN RIGHT OF WAY)	New drawing	Nov-25
06	3711	MINI ROUNDABOUT (ADDITIONAL RIGHT OF WAY)	New drawing	Nov-25
06	3715	SINGLE LANE ROUNDABOUT	New drawing	Nov-25
06	3720	TWO LANE ROUNDABOUT	New drawing	Nov-25
06	3820	RAISED INTERSECTION - CONCRETE	New drawing	Nov-25
06	3821	RAISED INTERSECTION - CONCRETE JOINT DETAILS	New drawing	Nov-25
06	3822	RAISED INTERSECTION - CONCRETE JOINT SEALANT DETAILS	New drawing	Nov-25
06	3850	3.00 - 4.00m ASPHALT SPEED TABLE	New drawing	Nov-25
06	3855	4.00m ASPHALT SPEED HUMP	New drawing	Nov-25
06	3860	2.5m ASPHALT SPEED HUMP	New drawing	Nov-25
06	3870	MID BLOCK COLLECTOR TWO STAGE CROSSING	New drawing	Nov-25
06	3871	MID BLOCK COLLECTOR CROSSING BULB	New drawing	Nov-25
06	3875	LOCAL STREET BIKEWAY MEDIAN DIVERTER	New drawing	Nov-25
06	3880	BEND OUT GATEWAY INTERSECTION TREATMENT (NO RIGHT TURN BAY)	New drawing	Nov-25
06	3881	BEND OUT GATEWAY INTERSECTION TREATMENT (WITH RIGHT TURN BAY)	New drawing	Nov-25
06	3882	LOCAL STREET BIKEWAY MEDIAN DIVERTER	New drawing	Nov-25
06	3890	COLLECTOR - COLLECTOR BULB	New drawing	Nov-25
06	3891	COLLECTOR - COLLECTOR BULB WITH BUS STOP	New drawing	Nov-25
06	3892	COLLECTOR - LOCAL BULB	New drawing	Nov-25
06	3893	COLLECTOR - COLLECTOR T-INTERSECTION BULB	New drawing	Nov-25
06	3894	COLLECTOR - LOCAL T-INTERSECTION BULB	New drawing	Nov-25
06	3895	LOCAL - COLLECTOR T-INTERSECTION BULB	New drawing	Nov-25

Version	DWG	Drawing Name	Revision	Date
06	4500	BIKE LANE TRANSIT STOP ISLAND	New drawing	Nov-25
06	5035	BEVELLED CURB	New drawing	Nov-25
06	5045	OVERBUILD DETAIL	New drawing	Nov-25
06	5046	CURB TRANSITIONS	New drawing	Nov-25
06	5100	MONOLITHIC WALK WITH 150mm CURB AND 250mm GUTTER	Updated wick drain location	Nov-25
06	5110	MONOLITHIC WALK WITH 150mm CURB AND 500mm GUTTER (RETROFIT)	Updated wick drain location	Nov-25
06	5120	ROLLED FACE MONOLITHIC WALK AND GUTTER	Updated wick drain location	Nov-25
06	5125	CONCRETE MONOWALK PANEL REPLACEMENT - 1.80m	New drawing	Nov-25
06	5140	CONCRETE WALKWAY - 1.80m	Updated notes	Nov-25
06	5145	CONCRETE WALKWAY FOR REVERSE HOUSING - 1.80m IN 6.00m ROW	New drawing	Nov-25
06	5146	CONCRETE WALKWAY FOR REVERSE HOUSING - 1.80m IN 4.00m ROW	New drawing	Nov-25
06	5150	CONCRETE WALKWAY - GREATER THAN 1.80m	Added special treatment detail	Nov-25
06	5155	BREEZEWAY ASPHALT PATH CONNECTION	New drawing	Nov-25
06	5160	SHARED PATHWAY	Revised drawing name and pavement structure	Nov-25
06	5161	SHARED PATHWAY JOINT DETAIL	New drawing	Nov-25
06	5165	TOP OF BANK SHARED PATHWAY	Revised drawing name and pavement structure	Nov-25
06	5170	GRANULAR WALKWAY	Revised surfacing course designation and pavement structure	Nov-25
06	5185	1.00m CONNECTOR WALK	New drawing	Nov-25
06	5200	WOODEN WALK	Revised stringer requirements, widths, and handrail heights.	Nov-25
06	5201	WOODEN STAIRS AND SUPPORT STRUCTURE	Revised details to add clarity, revised bracing details and requirements.	Nov-25
06	5210	PAVING BRICK INSTALLATION	Drawing removed	Nov-25
06	5215	PAVING BRICK CROSSWALK CONSTRUCTION	Revised drawing to focus on paving brick installation detail. Paving brick cross walks are no longer permitted.	Nov-25
06	5310	ALLEY CROSSING MONOWALK AND APRONS	Revised to RF curb. Revised rebar lengths.	Nov-25
06	5330	PRIVATE CROSSING MONOWALK AND APRONS	Revised to RF curb. Removed rebar requirement.	Nov-25
06	5340	PRIVATE CROSSING MONOWALK (RETROFIT)	Revised to RF curb. Removed rebar requirement.	Nov-25
06	5410	COMMERCIAL CROSSING MONOWALK AND BOULEVARD WALK (BOULEVARD < 1.50m)	Revised to RF curb. Revised rebar lengths.	Nov-25

Version	DWG	Drawing Name	Revision	Date
06	5341	PRIVATE CROSSING MONOLITHIC SHARED PATHWAY (RETROFIT)	New drawing	Nov-25
06	5400	COMMERCIAL CROSSING BOULEVARD WALK AND APRONS (BOULEVARD > 1.50m)	Revised rebar lengths.	Nov-25
06	5410	COMMERCIAL CROSSING MONOWALK AND BOULEVARD WALK (BOULEVARD < 1.50m)	Revised rebar lengths.	Nov-25
06	5510	CURB RAMP	Changed max curb ramp slope to align with drawing details	Nov-25
06	5520	TACTILE WALKING SURFACE INDICATOR (TWSI) LAYOUT FOR SEPARATE WALK	Added separation distance from back of curb to TWSI	Nov-25
06	5521	TACTILE WARNING SURFACE INDICATOR (TWSI) LAYOUT FOR WALK	Added dimensions and revised labelling	Nov-25
06	5522	TACTILE WALKING SURFACE INDICATOR (TWSI) LAYOUT FOR MID-BLOCK CROSSING	Added separation distance from back of curb to TWSI. Revised slope guidance on ramp.	Nov-25
06	5523	TACTILE WALKING SURFACE INDICATOR (TWSI) ORIENTATION FOR OFFSET INTERSECTIONS	Added dimensions and revised labelling	Nov-25
06	5530	TYPE A RAMP TWSI OPTION 1	Drawing removed	Nov-25
06	5531	TYPE A RAMP TWSI OPTION 2	Drawing removed	Nov-25
06	5600	MID-BLOCK BIKEWAY SLIP RAMP	Added dimensions	Nov-25
06	5605	BIKE RAMP DETAIL	New drawing	Nov-25
06	6001	SINGLE SLOPE CONCRETE BARRIERS	New drawing	Nov-25
06	6010	SLIPFORMED CONCRETE BARRIER 5.50m MEDIAN	Drawing removed	Nov-25
06	6020	CONCRETE BARRIER ON PAVED MEDIAN	Drawing removed	Nov-25
06	6030	END TRANSITION CONCRETE BARRIER	Drawing removed	Nov-25
06	6050	LIFT OUT FOR CONCRETE BARRIER	Drawing removed	Nov-25
06	6060	830mm CONCRETE SLIP-FORMED PARAPET WITH 1.00m SWALE	Drawing removed	Nov-25
06	6090	STANDARD TAPER AT BRIDGE PIERS CONCRETE BARRIER	Drawing removed	Nov-25
06	6210	TYPICAL BOLLARD LAYOUT AND INSTALLATION FOR 3.00m SHARED PATHWAY	Removed bollard in middle of pathway and added T-bollard	Nov-25
06	6230	TYPICAL BOLLARD LAYOUT FOR 3.00m ASPHALT SHARED PATHWAY WITHIN PIPELINE/POWER ROW	Removed bollard in middle of pathway and added T-bollard	Nov-25
06	6240	EMERGENCY KNOCK-DOWN POST (RETROFIT)	Drawing removed	Nov-25
06	6300	ASPHALT SPEED HUMP	Removed - replaced with new drawing 3855 / 3860	Nov-25
06	7976	CATCH BASINS IN WALKWAY RIGHT-OF-WAY	Added reference to Volume 3 treatments for CB	Nov-25
06	7980	BACKFILL DETAIL OF MAINTENANCE HOLE AND VALVE RAISED TO GRADE	Revised from "Manhole" to "Maintenance Hole"	Nov-25
06	7981	BACKFILL DETAIL OF MAINTENANCE HOLE AND VALVE RAISED TO GRADE (FILLCRETE OPTION)	Revised from "Manhole" to "Maintenance Hole"	Nov-25

<i>Version</i>	<i>DWG</i>	<i>Drawing Name</i>	<i>Revision</i>	<i>Date</i>
05		Adding standard drawings #3130, #3800, #3805, #3810, #3815, #3830, #3835, #3840, #3845, #3900, #5530, #5531, #6085, and #6525	New drawings	Aug-23
05	2040 2041	Updating standard drawings #2040, #2041	Updated drawings	Aug-23
03	2510	Adding in temporary cross-section	New drawing	Mar-21
02	all	Chapter 3 (Standard Drawings) Published	September 2018	Sept-18

Important Note:

Printed or downloaded copies of this document are not controlled and may not be the current version.

Strike-outs through content in this document indicated information no longer applicable.

TABLE OF CONTENTS

CHAPTER 3: COMPLETE STREETS STANDARD DRAWINGS

DRAWING CHANGE HISTORY	2-03-4
DRAWING INDEX	2-03-12
SECTION 1000 UTILITY CUT RESTORATION	2-03-22
1000 PAVEMENT RESTORATION AFTER UTILITY CUT	2-03-23
1010 ROAD SURFACE RESTORATION AFTER UTILITY CUT	2-03-24
1020 TRANSVERSE CUT RESTORATION ARTERIAL ROAD	2-03-25
1021 TRANSVERSE CUT RESTORATION 14.5m COLLECTOR ROAD	2-03-26
1022 TRANSVERSE CUT RESTORATION 11.5m COLLECTOR ROAD	2-03-27
1023 TRANSVERSE CUT RESTORATION LOCAL INDUSTRIAL ROAD	2-03-28
1024 TRANSVERSE CUT RESTORATION LOCAL RESIDENTIAL ROAD	2-03-29
1025 TRANSVERSE CUT RESTORATION ALLEYS	2-03-30
1030 CURB AND GUTTER / MONOWALK REPLACEMENT SAWCUT DETAILS	2-03-31
SECTION 2000 CROSS-SECTIONS	2-03-32
2000 TYPICAL BERM SECTION	2-03-33
2020 STAGED ARTERIAL GRADING REQUIREMENTS	2-03-34
2030 RESIDENTIAL SERVICE ROAD	2-03-35
2031 INDUSTRIAL SERVICE ROAD	2-03-36
2040 4.00m RESIDENTIAL ALLEY	2-03-37
2041 6.00m COMMERCIAL ALLEY	2-03-38
2042 RESIDENTIAL REVERSE HOUSING ALLEY - 7.50m ROW	2-03-39
2043 REVERSE HOUSING ALLEY WITH PARKING - 9.50m ROW	2-03-40
2044 REVERSE HOUSING ALLEY WITH PARKING AND WALK - 14.00m ROW	2-03-41
2045 RESIDENTIAL SHARED ALLEY - 6.00m ROW	2-03-42
2046 COMMERCIAL SHARED ALLEY - 8.00m - 10.00m ROW	2-03-43
2050 9.00m RURAL LOCAL / COLLECTOR ROADWAY	2-03-44
2060 TEMPORARY ACCESS / DETOUR ROAD	2-03-45
2210 9.00m LOCAL RESIDENTIAL (BOULEVARD WALK) - 17.00m ROW	2-03-46
2211 9.00m LOCAL RESIDENTIAL (ALTERNATIVE BOULEVARDS) - 17.00m ROW	2-03-47
2220 8.00m LOCAL RESIDENTIAL (BOULEVARD WALK) - 16.00m ROW	2-03-48
2221 8.00m LOCAL RESIDENTIAL (ALTERNATIVE BOULEVARDS) - 16.00m ROW	2-03-49
2230 8.00m LOCAL RESIDENTIAL (BOULEVARD WALK) - 17.00m ROW	2-03-50
2231 8.00m LOCAL RESIDENTIAL (ALTERNATIVE BOULEVARDS) - 17.00m ROW	2-03-51
2240 9.00m LOCAL RESIDENTIAL (BOULEVARD WALK) - 18.00m ROW	2-03-52
2241 9.00m LOCAL RESIDENTIAL (ALTERNATIVE BOULEVARDS) - 18.00m ROW	2-03-53
2250 9.00m OPEN SPACE LOCAL RESIDENTIAL (BOULEVARD WALK AND PATHWAY) - 17.00m ROW	2-03-54
2255 9.00 ENHANCED LOCAL WITH PATHWAY (PARKING ONE OR BOTH SIDES) - 19.30m ROW	2-03-55
2290A LOCAL ROAD BOULEVARD DETAILS - 4.00m BLVD & 1.800m BLVD WALK/2.0m GAS EASEMENT	2-03-56
2290B LOCAL ROAD BOULEVARD DETAILS - 4.00m BLVD & 1.800m BLVD WALK/2.7m MULTI PARTY EASEMENT	2-03-57
2291A LOCAL ROAD BOULEVARD DETAILS - 4.00m BLVD & 2.100m MONO WALK/2.0m GAS EASEMENT	2-03-58
2291B LOCAL ROAD BOULEVARD DETAILS - 4.00m BLVD & 2.100m MONO WALK/2.7m MULTI PARTY EASEMENT	2-03-59
2292A LOCAL ROAD BOULEVARD DETAILS - 4.00m BLVD & 2.175m MONO WALK/2.0m GAS EASEMENT	2-03-60
2292B LOCAL ROAD BOULEVARD DETAILS - 4.00m BLVD & 2.175m MONO WALK/2.7m MULTI PARTY EASEMENT	2-03-61

2293A	LOCAL ROAD BOULEVARD DETAILS - 4.15m BLVD & 1.800m BLVD WALK/2.0m GAS EASEMENT	2-03-62
2293B	LOCAL ROAD BOULEVARD DETAILS - 4.15m BLVD & 1.800m BLVD WALK/2.7m MULTI PARTY EASEMENT	2-03-63
2294A	LOCAL ROAD BOULEVARD DETAILS - 4.15m BLVD & 2.100m MONO WALK/2.0m GAS EASEMENT	2-03-64
2294B	LOCAL ROAD BOULEVARD DETAILS - 4.15m BLVD & 2.100m MONO WALK/2.7m MULTI PARTY EASEMENT	2-03-65
2295A	LOCAL ROAD BOULEVARD DETAILS - 4.15m BLVD & 2.175m MONO WALK/2.0m GAS EASEMENT	2-03-66
2295B	LOCAL ROAD BOULEVARD DETAILS - 4.15m BLVD & 2.175m MONO WALK/2.7m MULTI PARTY EASEMENT	2-03-67
2296A	LOCAL ROAD BOULEVARD DETAILS - 4.50m BLVD & 1.800m BLVD WALK/2.0m GAS EASEMENT	2-03-68
2296B	LOCAL ROAD BOULEVARD DETAILS - 4.50m BLVD & 1.800m BLVD WALK/2.7m MULTI PARTY EASEMENT	2-03-69
2297A	LOCAL ROAD BOULEVARD DETAILS - 4.50m BLVD & 2.175m MONO WALK/2.0m GAS EASEMENT	2-03-70
2297B	LOCAL ROAD BOULEVARD DETAILS - 4.50m BLVD & 2.175m MONO WALK/2.7m MULTI PARTY EASEMENT	2-03-71
2300	11.50m INDUSTRIAL LOCAL (MONOWALK) - 20.00m ROW	2-03-72
2310	11.50m INDUSTRIAL LOCAL (BOULEVARD WALK) - 20.00 ROW	2-03-73
2325	9.30m COLLECTOR WITH CYCLE TRACK- 22.0m ROW	2-03-74
2330	9.30m BASE COLLECTOR - 20.00m ROW	2-03-75
2331	ALTERNATE COLLECTOR BOULEVARDS A AND B	2-03-76
2332	ALTERNATE COLLECTOR BOULEVARDS C AND D (SCHOOL SITE)	2-03-77
2333	ALTERNATE COLLECTOR BOULEVARDS E (OPEN SPACE)	2-03-78
2345	11.50m COLLECTOR WITH PATHWAY - 24.00m ROW	2-03-79
2346	11.50m COLLECTOR WITH BIKE LANES - 27.70m ROW	2-03-80
2410	13.70m FOUR LANE COLLECTOR - 25.0m ROW	2-03-81
2411	13.20m INDUSTRIAL COLLECTOR - 24.00m ROW	2-03-82
2420	11.10m HYBRID INDUSTRIAL COLLECTOR (SHARED PATHWAY) - 30.55m ROW	2-03-83
2422	8.25m RETROFIT HYBRID INDUSTRIAL COLLECTOR (BOULEVARD WALK) - 20.00m ROW	2-03-84
2500	FIVE LANE UNDIVIDED ARTERIAL - 37.00m ROW	2-03-85
2510	FOUR LANE DIVIDED ARTERIAL - 37.00m ROW	2-03-86
2520	SIX LANE URBAN DIVIDED ARTERIAL - 44.00m ROW	2-03-87
2600	UTILITIES LOCATION PLAN WALKWAYS - 6.00m ROW	2-03-88
2720	SLOPE REGULATION RESIDENTIAL PRIVATE DRIVEWAY/PARKADE RAMP MONOWALK	2-03-89
2730	SLOPE REGULATIONS RESIDENTIAL PRIVATE DRIVEWAY/PARKADE RAMP BOULEVARD WALK	2-03-90

SECTION 3000 DESIGN DETAILS

2-03-91

3000	INDUSTRIAL SERVICE ROAD "BULB" ENTRANCE	2-03-92
3010	MAJOR COMMERCIAL ACCESS TYPICAL CURB RETURN FORMAT	2-03-93
3020	RURAL LOCAL ACCESS	2-03-94
3031	ALTERNATIVE STANDARD ALLEY CORNER CUT (5.00m x 5.00m)	2-03-95
3032	ALTERNATIVE ALLEY CORNER WIDENING IN LIEU OF 5.00m x 5.00m CORNER CUT OFF	2-03-96
3040	PUBLIC ALLEY CUL-DE-SAC AND CORNER CUTS	2-03-97
3041	ALTERNATIVE PUBLIC ALLEY CUL-DE-SAC AND CORNER CUTS	2-03-98
3100	RIGHT TURN STANDARD ARTERIAL TO ARTERIAL CHANNELIZED HIGH ENTRY ANGLE (YIELD CONDITION)	2-03-99
3110	RIGHT TURN STANDARD ARTERIAL TO ARTERIAL CHANNELIZED LOW EXIT ANGLE (FREE FLOW)	2-03-100
3120	RIGHT TURN STANDARD ARTERIAL TO ARTERIAL UNCHANNELIZED SIMPLE CURVE (STOP CONDITION)	2-03-101
3130	RIGHT TURN WITH MOUNTABLE CURB	2-03-102
3200	RIGHT TURN BAY STANDARD ARTERIAL TO COLLECTOR	2-03-103
3210	RIGHT TURN BAY STANDARD ARTERIAL TO ARTERIAL	2-03-104
3300	LEFT TURN BAY STANDARD NARROW MEDIAN	2-03-105
3310	LEFT TURN BAY STANDARD WIDE MEDIAN	2-03-106
3320	LEFT TURN STANDARD CHANNELIZED SLOT	2-03-107
3350	RIGHT AND LEFT TURN BAY STANDARD CURVED MAIN LINE	2-03-108
3400	ISLAND LAYOUT FOR INTRODUCTION OF CHANNELIZATION	2-03-109

3500	RESIDENTIAL CUL-DE-SAC (WITHOUT ISLAND)	2-03-110
3510	RESIDENTIAL CUL-DE-SAC (CIRCULAR ISLAND)	2-03-111
3520	RESIDENTIAL CUL-DE-SAC (CIRCULAR OFFSET ISLAND)	2-03-112
3530	RESIDENTIAL EYEBROW (CIRCULAR ISLAND)	2-03-113
3540	SIDEWALK REQUIREMENTS CUL-DE-SAC	2-03-114
3700	NEIGHBOURHOOD TRAFFIC CIRCLE	2-03-115
3710	MINI ROUNDABOUT (WITHIN RIGHT OF WAY)	2-03-116
3711	MINI ROUNDABOUT (ADDITIONAL RIGHT OF WAY)	2-03-117
3715	SINGLE LANE ROUNDABOUT	2-03-118
3720	TWO LANE ROUNDABOUT	2-03-119
3800	RAISED CROSSING AT INTERSECTION - ASPHALT (RETROFIT)	2-03-120
3805	RAISED CROSSING AT CROSSING - CONCRETE	2-03-121
3810	CONCRETE DETAILS - RAISED CROSSING	2-03-122
3815	RAISED INTERSECTION - ASPHALT	2-03-123
3820	RAISED INTERSECTION - CONCRETE	2-03-124
3821	RAISED INTERSECTION - CONCRETE JOINT DETAILS	2-03-125
3822	RAISED INTERSECTION - CONCRETE JOINT SEALANT DETAILS	2-03-126
3830	RAISED MID BLOCK CROSSING - ASPHALT	2-03-127
3835	RAISED MID BLOCK CROSSING - CONCRETE	2-03-128
3840	CONTINUOUS CROSSING	2-03-129
3845	CONTINUOUS CROSSING ISOMETRIC DETAIL	2-03-130
3850	3.00 - 4.00m ASPHALT SPEED TABLE	2-03-131
3855	4.00m ASPHALT SPEED HUMP	2-03-132
3860	2.5m ASPHALT SPEED HUMP	2-03-133
3870	MID BLOCK COLLECTOR TWO STAGE CROSSING	2-03-134
3871	MID BLOCK COLLECTOR CROSSING BULB	2-03-135
3875	LOCAL STREET BIKEWAY MEDIAN DIVERTER	2-03-136
3880	BEND OUT GATEWAY INTERSECTION TREATMENT (NO RIGHT TURN BAY)	2-03-137
3881	BEND OUT GATEWAY INTERSECTION TREATMENT (WITH RIGHT TURN BAY)	2-03-138
3890	COLLECTOR - COLLECTOR BULB	2-03-139
3891	COLLECTOR - COLLECTOR BULB WITH BUS STOP	2-03-140
3892	COLLECTOR - LOCAL BULB	2-03-141
3893	COLLECTOR - COLLECTOR T-INTERSECTION BULB	2-03-142
3894	COLLECTOR - LOCAL T-INTERSECTION BULB	2-03-143
3895	LOCAL - COLLECTOR T-INTERSECTION BULB	2-03-144
3900	BOULEVARD SIDEWALK TRANSITION AT TRANSFORMER	2-03-145
SECTION 4000 TRANSIT DETAILS		2-03-146
4000	LOCATION OF BUS STOP (UNCHANNELIZED INTERSECTION)	2-03-147
4010	LOCATION OF BUS STOP (CHANNELIZED INTERSECTION)	2-03-148
4100	BUS STOP AND AMENITIES PAD MONOWALK	2-03-149
4110	BUS STOP AND AMENITIES PAD BOULEVARD WALK	2-03-150
4200	BUS STOP AND AMENITIES PAD RURAL ROADWAY	2-03-151
4250	CLASS 'A' CONCRETE BUS STOP PAD (RETROFIT)	2-03-152
4300	TRANSIT TURNAROUND (OFFSET)	2-03-153
4400	SAWTOOTH TRANSIT BAY TRANSIT TERMINAL SITE	2-03-154
4500	BIKE LANE TRANSIT STOP ISLAND	2-03-155

SECTION 5000 CONSTRUCTION DETAILS	2-03-156
5000 150mm CURB WITH 250mm GUTTER	2-03-157
5001 150mm CURB WITH REVERSE 250mm GUTTER	2-03-158
5010 150mm CURB AND 250mm GUTTER WITH MONO CONCRETE HEADER	2-03-159
5011 150mm CURB AND 250mm REVERSE GUTTER WITH MONO CONCRETE HEADER	2-03-160
5020 STRAIGHT FACE CONCRETE CURBLINE WALK/BUS STOP (RETROFIT)	2-03-161
5021 ROLLED FACE CURBLINE WALK (RETROFIT)	2-03-162
5022 150mm CURB AND 500mm GUTTER (RETROFIT)	2-03-163
5023 125mm SEMI-MOUNTABLE CURB AND 250mm GUTTER	2-03-164
5024 80mm ROLLED MOUNTABLE FACE CURB AND 250mm GUTTER	2-03-165
5030 500mm/1000mm CONCRETE V-GUTTERS	2-03-166
5035 BEVELLED CURB	2-03-167
5040 CONCRETE BARRIER CURB	2-03-168
5045 OVERBUILD DETAIL	2-03-169
5046 CURB TRANSITIONS	2-03-170
5051 TEMPORARY SLAB-ON CONCRETE CURB	2-03-171
5052 TEMPORARY SLAB-ON ASPHALT CURB	2-03-172
5060 DEPRESSED CURB AND GUTTER FOR CATCHBASIN	2-03-173
5061 CATCHBASIN TREATMENT 50mm OVERLAY OF GUTTER	2-03-174
5070 LAWN MOWER ACCESS TO MEDIAN	2-03-175
5100 MONOLITHIC WALK WITH 150mm CURB AND 250mm GUTTER	2-03-176
5110 MONOLITHIC WALK WITH 150mm CURB AND 500mm GUTTER (RETROFIT)	2-03-177
5120 ROLLED FACE MONOLITHIC WALK AND GUTTER	2-03-178
5125 CONCRETE MONOWALK PANEL REPLACEMENT - 1.80m	2-03-179
5130 EMERGENCY ACCESS ROAD CONCRETE	2-03-180
5140 CONCRETE WALKWAY - 1.80m	2-03-181
5145 CONCRETE WALKWAY FOR REVERSE HOUSING - 1.80m IN 6.00m ROW	2-03-182
5146 CONCRETE WALKWAY FOR REVERSE HOUSING - 1.80m IN 4.00m ROW	2-03-183
5150 CONCRETE WALKWAY - GREATER THAN 1.80m	2-03-184
5155 BREEZEWAY ASPHALT PATH CONNECTION	2-03-185
5160 SHARED PATHWAY	2-03-186
5161 SHARED PATHWAY JOINT DETAIL	2-03-187
5165 TOP OF BANK SHARED PATHWAY	2-03-188
5170 GRANULAR WALKWAY	2-03-189
5180 SIDEWALK CONSTRUCTION AT TREE OPENING	2-03-190
5185 1.00m CONNECTOR WALK	2-03-191
5200 WOODEN WALK	2-03-192
5201 WOODEN STAIRS AND SUPPORT STRUCTURE	2-03-193
5205 WOODEN NOISE ATTENUATION FENCE	2-03-194
5215 PAVING BRICK INSTALLATION	2-03-195
5300 ALLEY CROSSING BOULEVARD WALK AND APRONS	2-03-196
5310 ALLEY CROSSING MONOWALK AND APRONS	2-03-197
5320 PRIVATE CROSSING SEPARATE WALK AND APRONS	2-03-198
5330 PRIVATE CROSSING MONOWALK AND APRONS	2-03-199
5340 PRIVATE CROSSING MONOWALK (RETROFIT)	2-03-200
5341 PRIVATE CROSSING MONOLITHIC SHARED PATHWAY (RETROFIT)	2-03-201
5400 COMMERCIAL CROSSING BOULEVARD WALK AND APRONS (BOULEVARD > 1.50m)	2-03-202
5410 COMMERCIAL CROSSING MONOWALK AND BOULEVARD WALK (BOULEVARD < 1.50m)	2-03-203

5500	CURB RAMP LOCATIONS	2-03-204
5510	CURB RAMP	2-03-205
5520	TACTILE WALKING SURFACE INDICATOR (TWSI) LAYOUT FOR SEPARATE WALK	2-03-206
5521	TACTILE WARNING SURFACE INDICATOR (TWSI) LAYOUT FOR WALK	2-03-207
5522	TACTILE WALKING SURFACE INDICATOR (TWSI) LAYOUT FOR MID-BLOCK CROSSING	2-03-208
5523	TACTILE WALKING SURFACE INDICATOR (TWSI) ORIENTATION FOR OFFSET INTERSECTIONS	2-03-209
5524	TACTILE WALKING SURFACE INDICATOR (TWSI) MEDIAN DETAIL	2-03-210
5600	MID-BLOCK BIKEWAY SLIP RAMP	2-03-211
5605	BIKE RAMP DETAIL	2-03-212
5610	CENTRE MEDIAN END TREATMENT	2-03-213
5620	WIDE MEDIAN END TREATMENT	2-03-214
5630	CENTER MEDIAN REHABILITATION	2-03-215
5700	MULTI-PARTY UTILITIES TRENCHING	2-03-216
SECTION 6000 / 7000 MISCELLANEOUS		2-03-217
6001	SINGLE SLOPE CONCRETE BARRIERS	2-03-218
6085	HANDRAIL DETAILS	2-03-219
6100	PRE-CAST CONCRETE MINI-BARRIER	2-03-220
6101	END TRANSITION PRE-CAST CONCRETE MINI-BARRIER	2-03-221
6200	TYPICAL BOLLARD LAYOUT AND INSTALLATION FOR 1.80m CONCRETE WALKWAYS	2-03-222
6210	TYPICAL BOLLARD LAYOUT AND INSTALLATION FOR 3.00m SHARED PATHWAY	2-03-223
6220	TYPICAL BOLLARD WITH GALVANIZED STEEL W-SECTION	2-03-224
6230	TYPICAL BOLLARD LAYOUT FOR 3.00m ASPHALT SHARED PATHWAY WITHIN PIPELINE/POWER ROW	2-03-225
6250	T-BOLLARD IN EMERGENCY ACCESS	2-03-226
6251	T-BOLLARD ASSEMBLY DETAIL	2-03-227
6500	COST SHARE PROJECT SIGN	2-03-228
6510	AUXILIARY PROJECT SIGN	2-03-229
6520	ARTERIAL ROAD PROJECT SIGN DEVELOPER-BUILT PROJECTS	2-03-230
6525	BRIDGE/CULVERT STANDARD IDENTIFICATION PLAQUES AND BENCHMARK TABLETS	2-03-231
6530	TYPICAL A-FRAME SIGN	2-03-232
6600	MAINTENANCE HOLE INSTALLATION FOR SURVEY CONTROL MARKERS DEPTHS BETWEEN 0.20m - 0.60m	2-03-233
7976	CATCH BASINS IN WALKWAY RIGHT-OF-WAY	2-03-234
7980	BACKFILL DETAIL OF MAINTENANCE HOLE AND VALVE RAISED TO GRADE	2-03-235
7981	BACKFILL DETAIL OF MAINTENANCE HOLE AND VALVE RAISED TO GRADE (FILLCRETE OPTION)	2-03-236

PURPOSE / INTENT OF THE DOCUMENT

The Complete Streets Design and Construction Standards (CSDCS) document provides a single point of reference that supports the planning, design, and construction of Complete Streets in Edmonton. It integrates the best practices in Complete Streets design philosophy and guidance introduced in the City's 2013 Complete Streets Guidelines with the City of Edmonton's former Roadway Design Standards and Construction Specifications in alignment with the City's Complete Streets Policy C573B.

The intent of these Complete Streets Design and Construction Standards is to encourage a holistic approach to street design that will develop a network of streets that are safe, attractive, comfortable, and welcoming to all users in all seasons, while considering operational and maintenance challenges. The document introduces the 'Design Domain' approach which allows flexibility in design through variance in street element design values based on the modal priorities and context of a specific corridor.

From a technical perspective, the document is intended primarily for design professionals and City builders both private and public. Though the document can be utilized by communities and the public, a less technical companion document will better serve those users.

The Complete Streets Design and Construction Standards are intended to be a living document, with regular updates to incorporate changes in best practice and their application in the Edmonton context.

THE COMPLETE STREETS APPROACH

Historically in Edmonton, transportation systems have been designed based on roadway functional classification with the primary focus on accommodating motor vehicle connections to destinations. Roadways designed in this fashion typically function as a link that primarily moves people in vehicles from Point A to Point B and are typically referred to as 'roads'.

When other modes of transportation, such as walking and cycling are considered, there are competing demands for limited space and several challenges arise when designing a 'street':

- + How can the often-competing demands of people walking, riding bikes, taking transit, delivering goods, driving, and being driven be accommodated?
- + How can the design reflect the varying land uses along a corridor today and in the future?
- + How can cost-effective innovations, such as sustainable stormwater practices and improved urban design, be incorporated?
- + How can the design accommodate essential infrastructure such as trees, hydrants, and street lights?
- + How are placemaking elements provided and how might they vary to reflect unique community needs along a corridor?

Complete Streets attempts to address these challenges and represents a change from the past vehicle-focused roadway design philosophy.

The Complete Streets Design and Construction Standards provide context sensitive direction for the planning, design, and construction of streets for users of all modes. Over time, use of these standards will result in the creation of a **mobility system** that will accommodate the needs of all modes of travel in a safe, context sensitive manner. To accomplish this, some streets will prioritize certain modes over others. For example, a complete street in a shopping district may place priority on a person walking, cycling, and riding public transit, while a freeway will provide for high quality motor vehicle commuter traffic and goods movements. So, while each street in a network may not be designed to accommodate or prioritize every mode of transportation, the network of streets and off-street pathways will accommodate movements for users of all modes.

HOW TO USE THIS DOCUMENT

These Complete Streets Design and Construction Standards are comprised of three chapters as follows:

Chapter 1: Complete Streets Design Standards

contains higher level Complete Streets design philosophy and guidance. This Chapter draws upon existing content from Edmonton's original Complete Streets Guidelines and previous Design Standards and Construction Specifications, as well as the Transportation Association of Canada's (TAC) Geometric Design Guide for Canadian Roads (GDG) 2017. Chapter 1 is further broken down into three sections:

- + **Section 1.0: Concepts and Philosophy for Complete Streets Design.**
- + **Section 2.0: Design Process, Trade-offs and Evaluation.**
- + **Section 3.0: Design Requirements for Complete Streets Design.**
 - + Using Sections 1.0, 2.0, and 3.0, designers can produce context sensitive, functional, and sustainable street designs based on the design requirements for the street type based on its associated users.

Chapter 2: Construction Specifications contains detailed specifications that have been updated to align with best practices in construction methodology.

Chapter 3: Standard Drawings contains standard drawings that can be used in the design of streets in Edmonton including street cross sections, intersection elements, and other geometric design details.

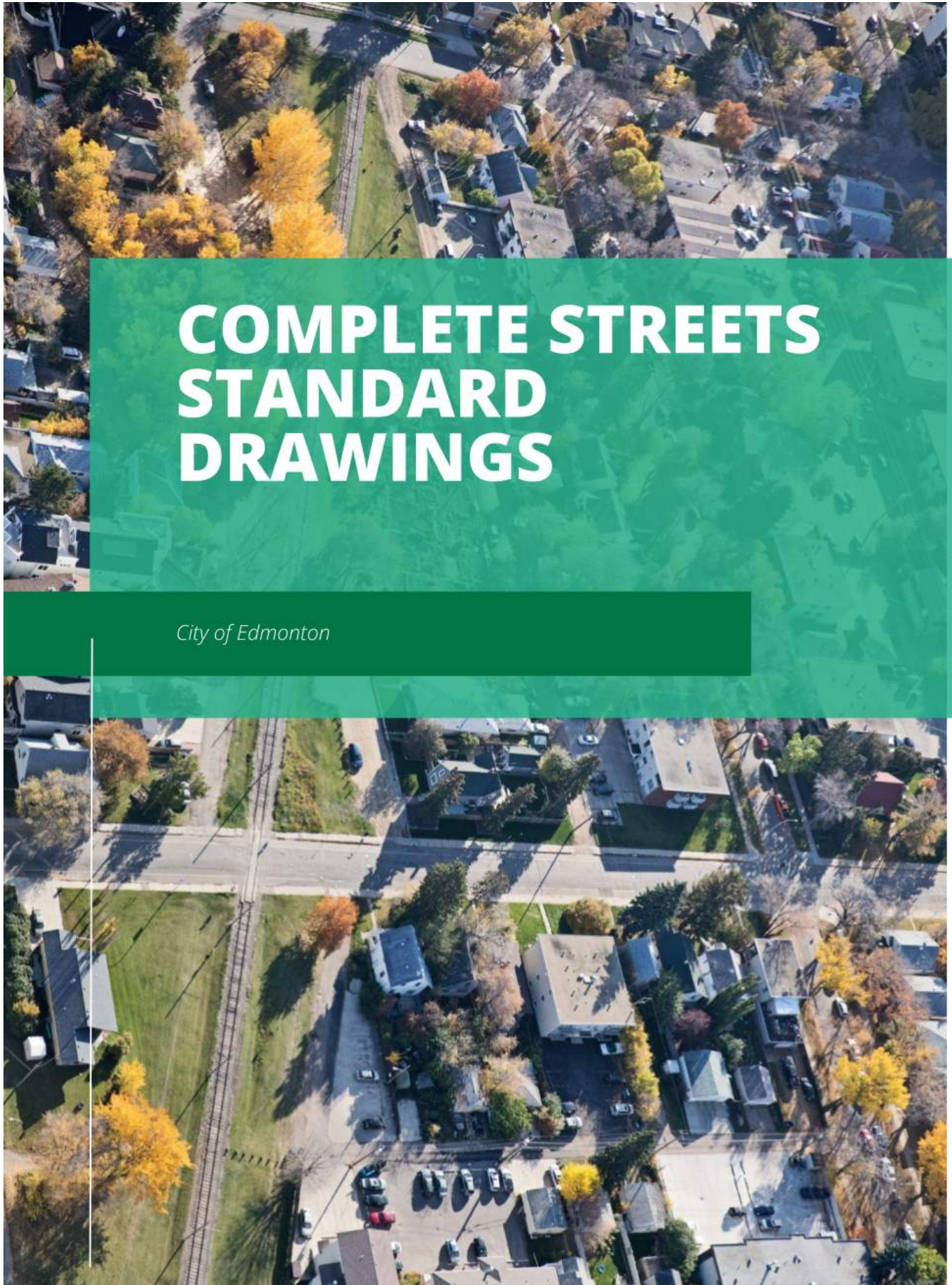

COMPLETE STREETS STANDARD DRAWINGS

City of Edmonton



Standard Drawings

SECTION 1000 – UTILITY CUT RESTORATION

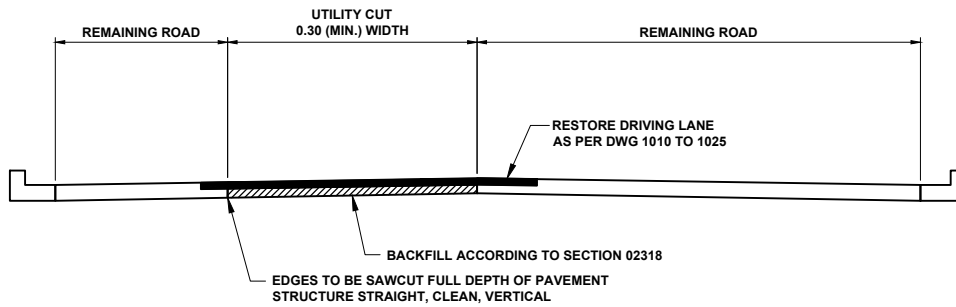
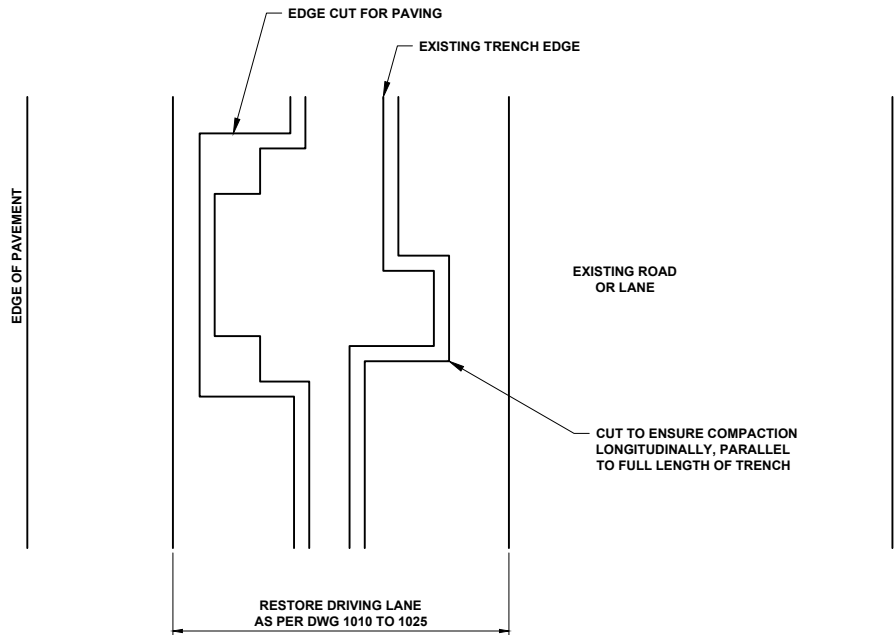

NOTE:

1. REMOVE AND REPLACE PAVEMENT STRUCTURE TO EDGE OF PAVEMENT (TO LIP OF GUTTER) WHEN WIDTH OF REMAINING ROADS <1.50m.
2. REFER TO CONSTRUCTION SPECIFICATIONS SECTION 3.2 - UTILITY RESTORATION.

**ALL DIMENSIONS
IN METRES UNLESS
OTHERWISE NOTED**



STANDARD DRAWING

PAVEMENT RESTORATION AFTER UTILITY CUT

DATE APPROVED: **2025**

DRAWN BY: **FR**

APPROVED: 

DRAWING NUMBER: **1000**

SCALE: **N.T.S.**

CHECKED BY: **JN**

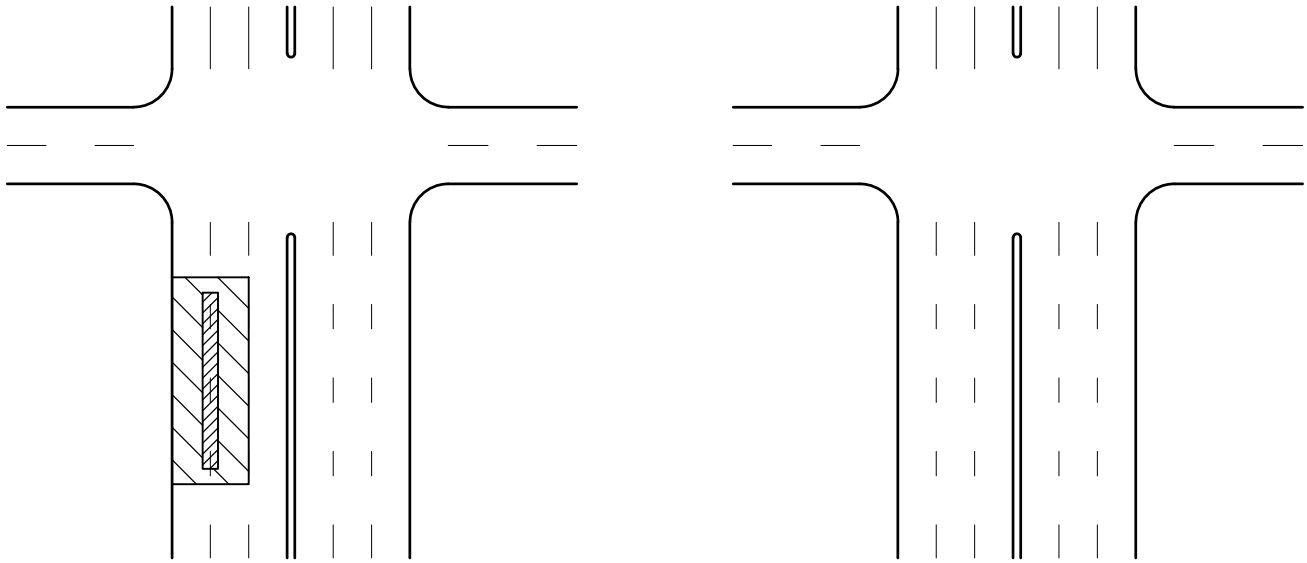

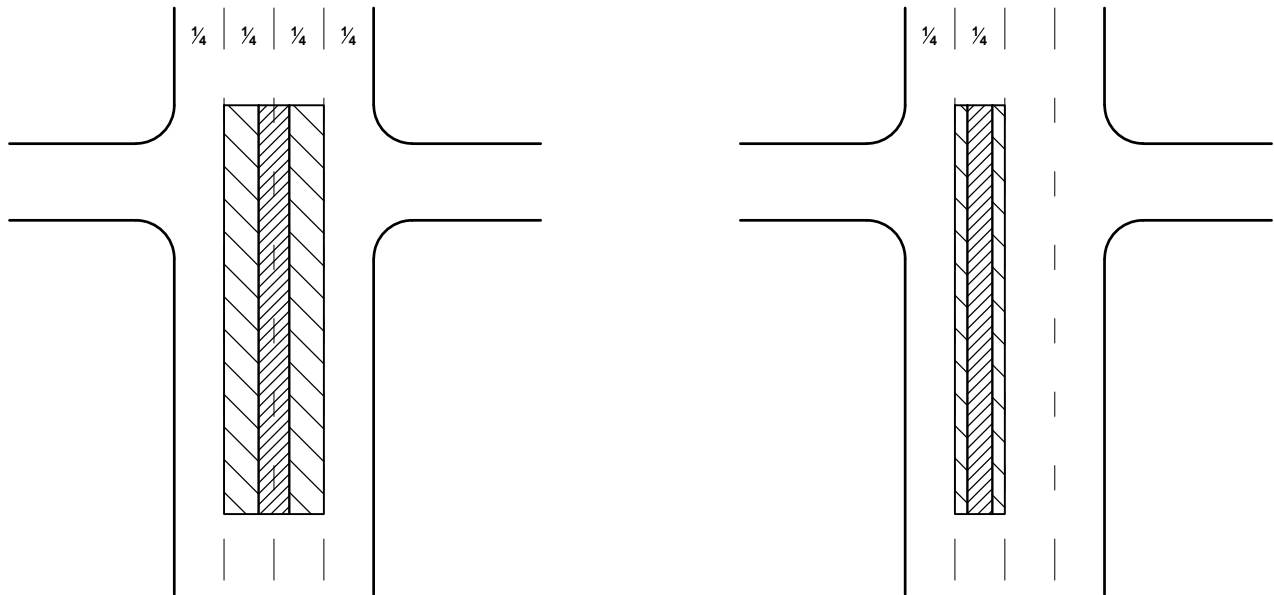

ROAD SURFACE WITH LANE MARKINGS



ROAD SURFACE WITH NO LANE MARKINGS

LEGEND

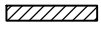
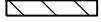
-  PAVEMENT EDGE
-  LANE MARKING
-  UTILITY CUT
-  OVERLAY

ALL DIMENSIONS
IN METRES UNLESS
OTHERWISE NOTED



STANDARD DRAWING

ROAD SURFACE RESTORATION AFTER UTILITY CUT

DATE APPROVED: **2025**

DRAWN BY: **FR**

APPROVED: 

DRAWING NUMBER: **1010**

SCALE: **N.T.S.**

CHECKED BY: **JN**

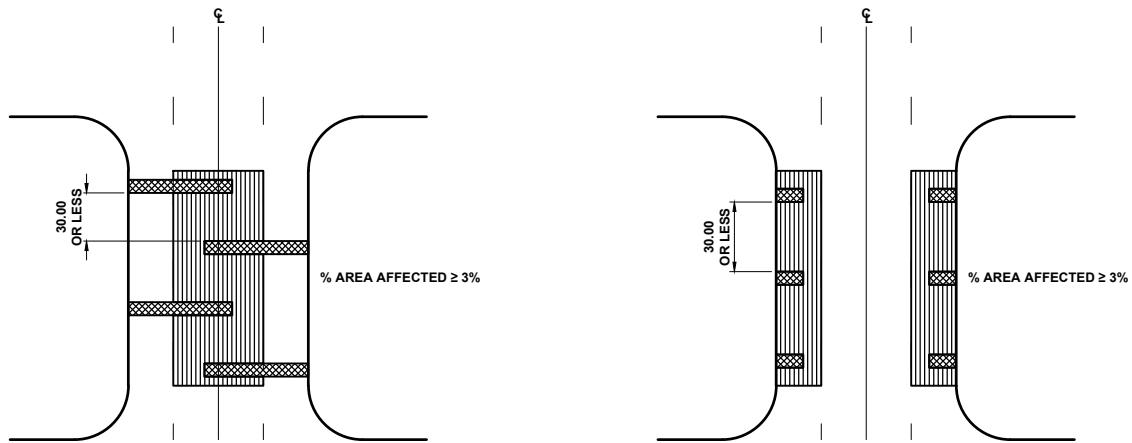

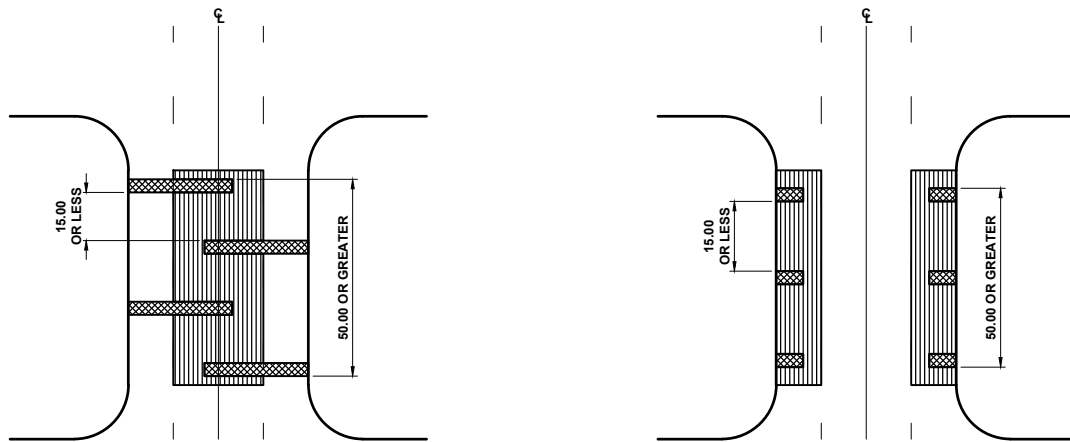

PQI 5.0 ≥ (OTHER LOCATIONS)



PQI < 5.0 (OTHER LOCATIONS)

$$\% \text{ AREA AFFECTED} = \frac{\text{TOTAL REPAIR AREA}}{\text{UTILITY RESTORATION AREA}} \times 100$$

LEGEND

-  CURB & GUTTER / EDGE OF PAVEMENT
-  UTILITY RESTORATION AREA
-  REPAIR AREA

**ALL DIMENSIONS
IN METRES UNLESS
OTHERWISE NOTED**



STANDARD DRAWING

TRANSVERSE CUT RESTORATION ARTERIAL ROAD

DATE APPROVED: **2025**
SCALE: **N.T.S.**

DRAWN BY: **FR**
CHECKED BY: **JN**

APPROVED: 

DRAWING NUMBER: **1020**

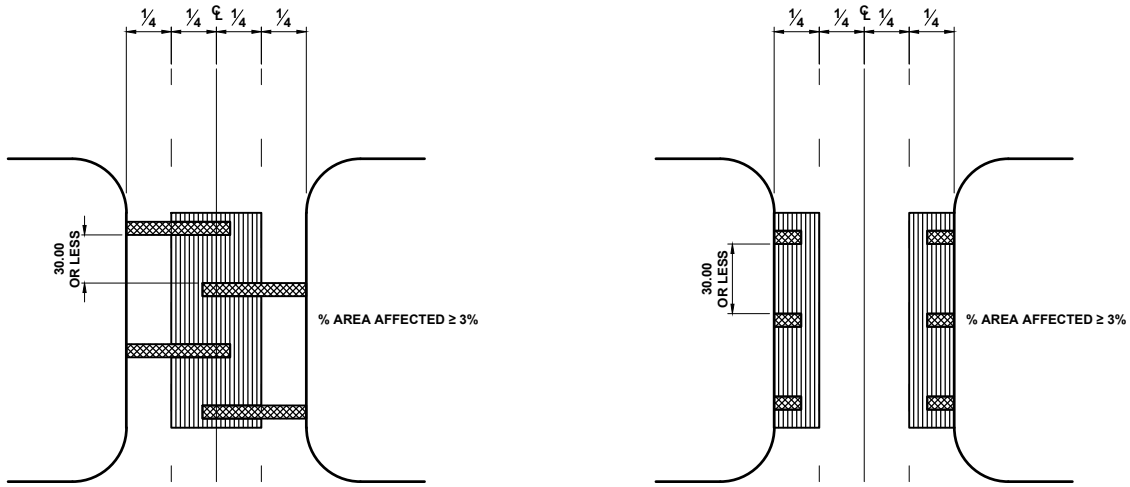

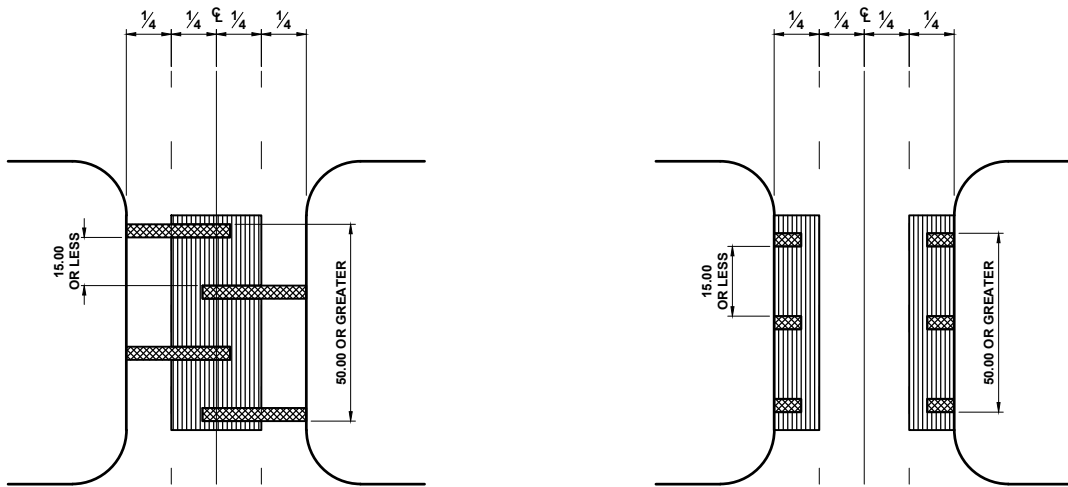

PQI 5.0 ≥ (OTHER LOCATIONS)



PQI < 5.0 (OTHER LOCATIONS)

$$\% \text{ AREA AFFECTED} = \frac{\text{TOTAL REPAIR AREA}}{\text{UTILITY RESTORATION AREA}} \times 100$$

LEGEND

-  CURB & GUTTER / EDGE OF PAVEMENT
-  UTILITY RESTORATION AREA
-  REPAIR AREA

**ALL DIMENSIONS
IN METRES UNLESS
OTHERWISE NOTED**



STANDARD DRAWING

TRANSVERSE CUT RESTORATION 14.5m COLLECTOR ROAD

DATE APPROVED: **2025**
SCALE: **N.T.S.**

DRAWN BY: **FR**
CHECKED BY: **JN**

APPROVED: 

DRAWING NUMBER: **1021**

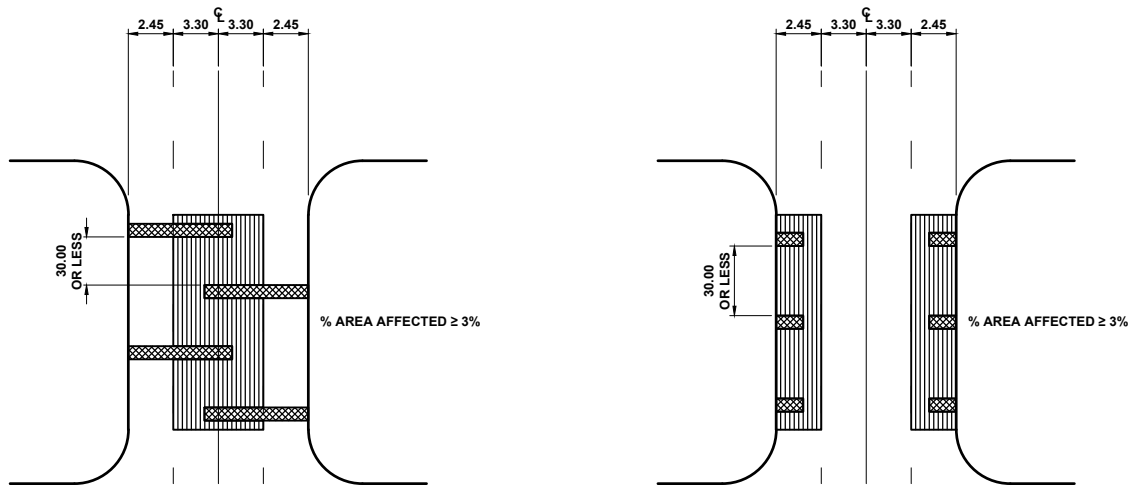

PQI 5.0 ≥ (OTHER LOCATIONS)

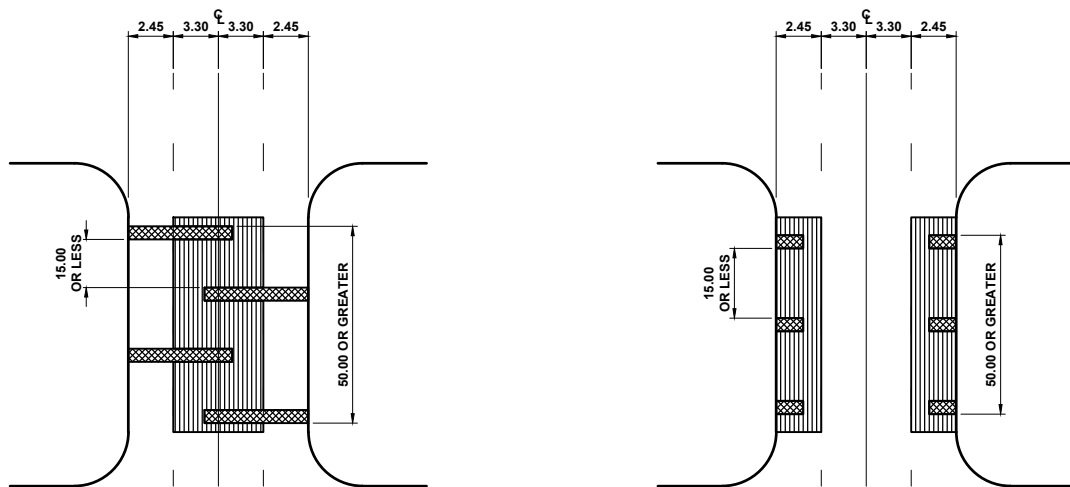

PQI < 5.0 (OTHER LOCATIONS)

$$\% \text{ AREA AFFECTED} = \frac{\text{TOTAL REPAIR AREA}}{\text{UTILITY RESTORATION AREA}} \times 100$$

LEGEND

- CURB & GUTTER / EDGE OF PAVEMENT
- UTILITY RESTORATION AREA
- REPAIR AREA

**ALL DIMENSIONS
IN METRES UNLESS
OTHERWISE NOTED**

STANDARD DRAWING

TRANSVERSE CUT RESTORATION 11.50m COLLECTOR ROAD

DATE APPROVED: **2025**

SCALE: **N.T.S.**

DRAWN BY: **FR**

CHECKED BY: **JN**

APPROVED:

DRAWING NUMBER: **1022**

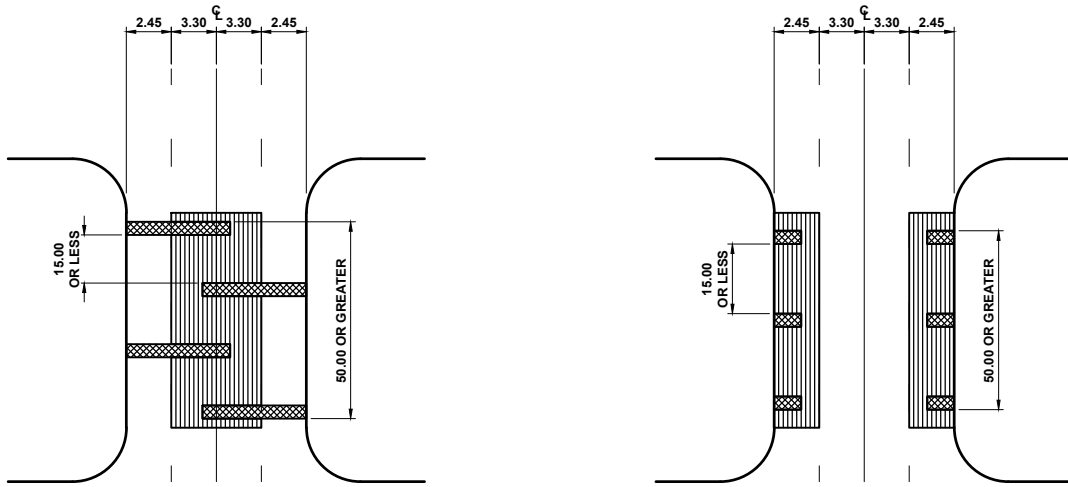

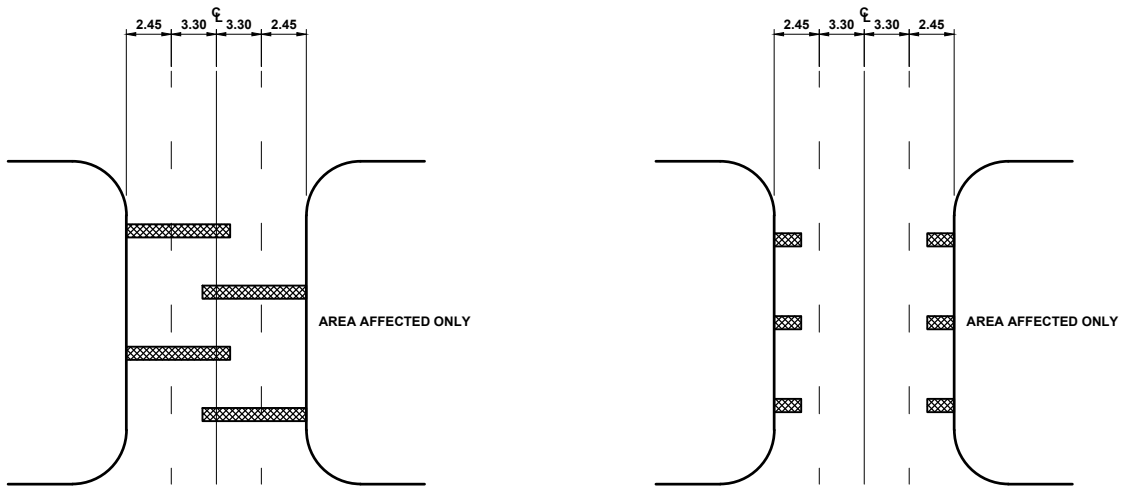

PQI 5.0 ≥ (OTHER LOCATIONS)



PQI < 5.0 (OTHER LOCATIONS)

$$\% \text{ AREA AFFECTED} = \frac{\text{TOTAL REPAIR AREA}}{\text{UTILITY RESTORATION AREA}} \times 100$$

LEGEND

-  CURB & GUTTER / EDGE OF PAVEMENT
-  UTILITY RESTORATION AREA
-  REPAIR AREA

**ALL DIMENSIONS
IN METRES UNLESS
OTHERWISE NOTED**



STANDARD DRAWING

TRANSVERSE CUT RESTORATION LOCAL INDUSTRIAL ROAD

DATE APPROVED: **2025**
SCALE: **N.T.S.**

DRAWN BY: **FR**
CHECKED BY: **JN**

APPROVED: 

DRAWING NUMBER: **1023**

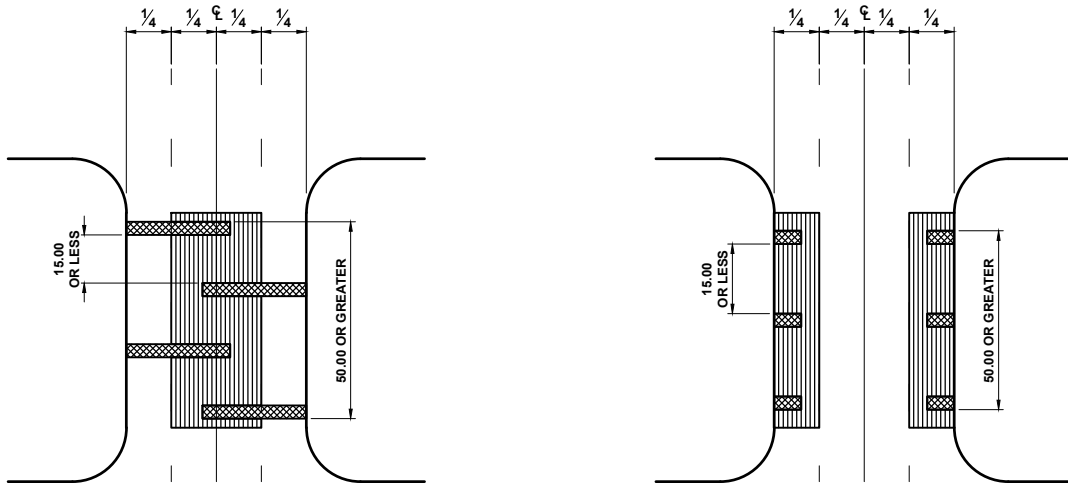

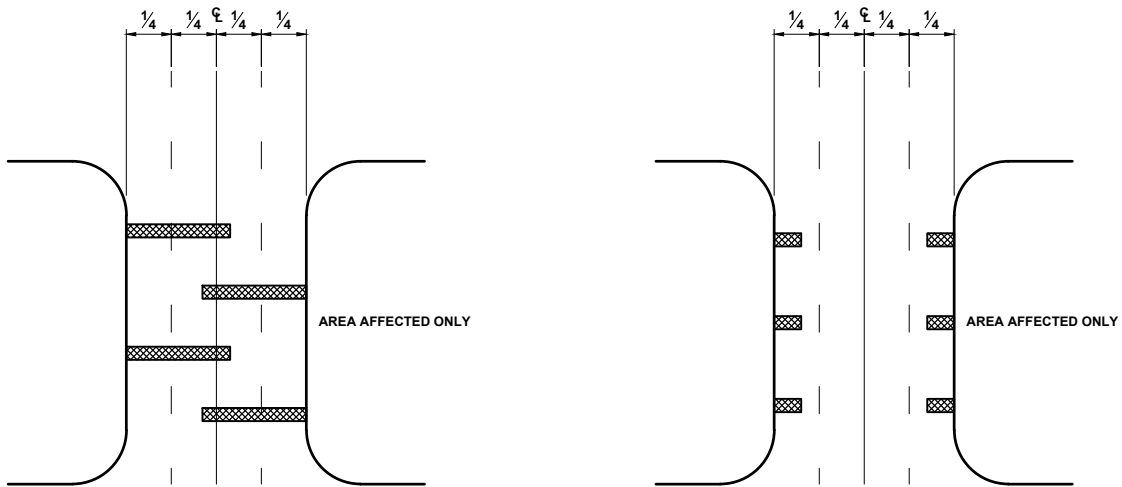

PQI 5.0 ≥ (OTHER LOCATIONS)



PQI < 5.0 (OTHER LOCATIONS)

$$\% \text{ AREA AFFECTED} = \frac{\text{TOTAL REPAIR AREA}}{\text{UTILITY RESTORATION AREA}} \times 100$$

LEGEND

-  CURB & GUTTER / EDGE OF PAVEMENT
-  UTILITY RESTORATION AREA
-  REPAIR AREA

**ALL DIMENSIONS
IN METRES UNLESS
OTHERWISE NOTED**



STANDARD DRAWING

TRANSVERSE CUT RESTORATION LOCAL RESIDENTIAL ROAD

DATE APPROVED: **2025**
SCALE: **N.T.S.**

DRAWN BY: **FR**
CHECKED BY: **JN**

APPROVED: 

DRAWING NUMBER: **1024**

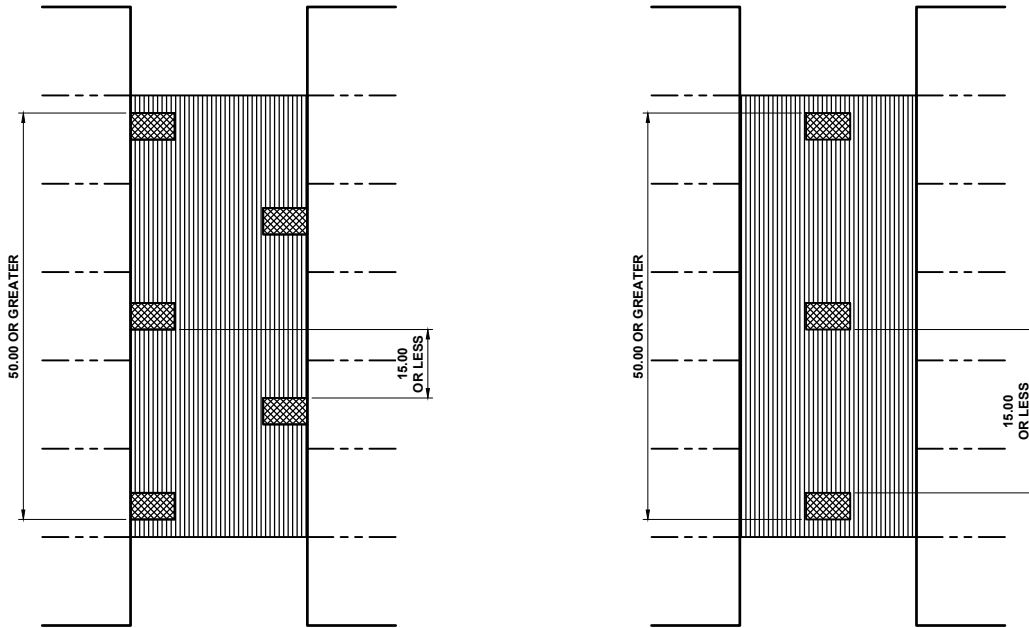

VCI 5.0 ≥ (OTHER LOCATIONS)

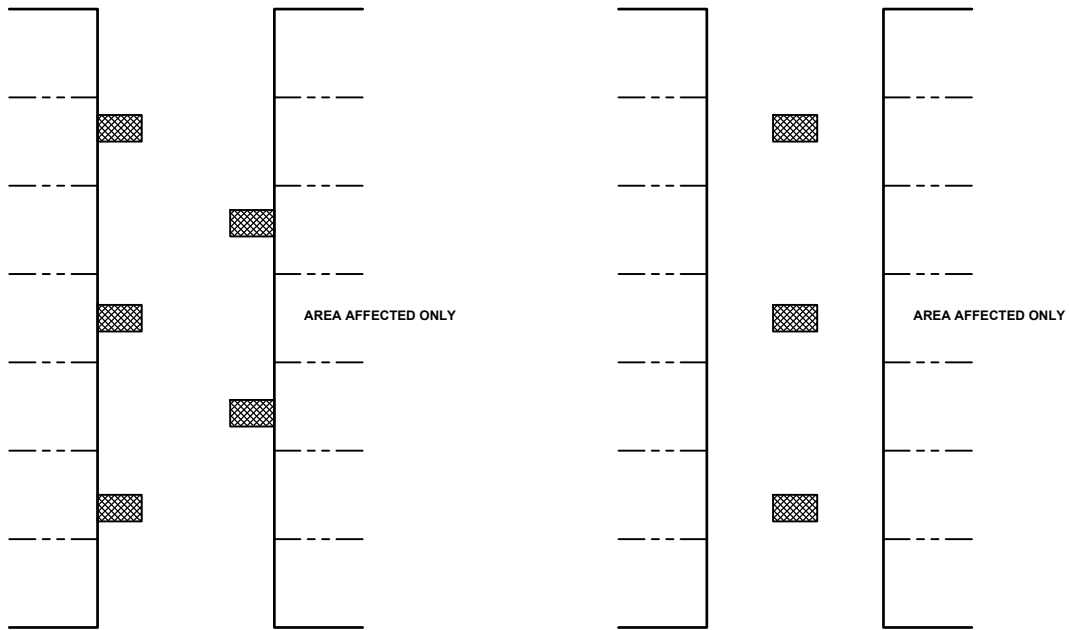

VCI < 5.0 (OTHER LOCATIONS)

LEGEND

- CURB & GUTTER / FENCE LINE
- PROPERTY LINE
- ▨ UTILITY RESTORATION AREA
- ▩ REPAIR AREA

$$\% \text{ AREA AFFECTED} = \frac{\text{TOTAL REPAIR AREA}}{\text{UTILITY RESTORATION AREA}} \times 100$$

**ALL DIMENSIONS
IN METRES UNLESS
OTHERWISE NOTED**



STANDARD DRAWING

TRANSVERSE CUT RESTORATION ALLEYS

DATE APPROVED: **2025**

DRAWN BY: **FR**

APPROVED:

DRAWING NUMBER: **1025**

SCALE: **N.T.S.**

CHECKED BY: **JN**

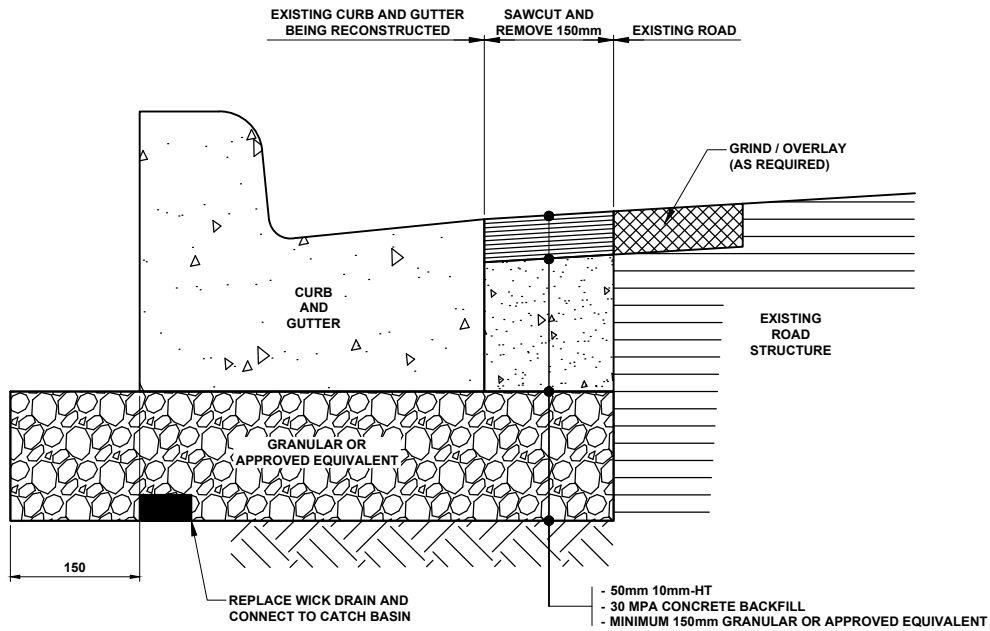

CURB AND GUTTER REPLACEMENT

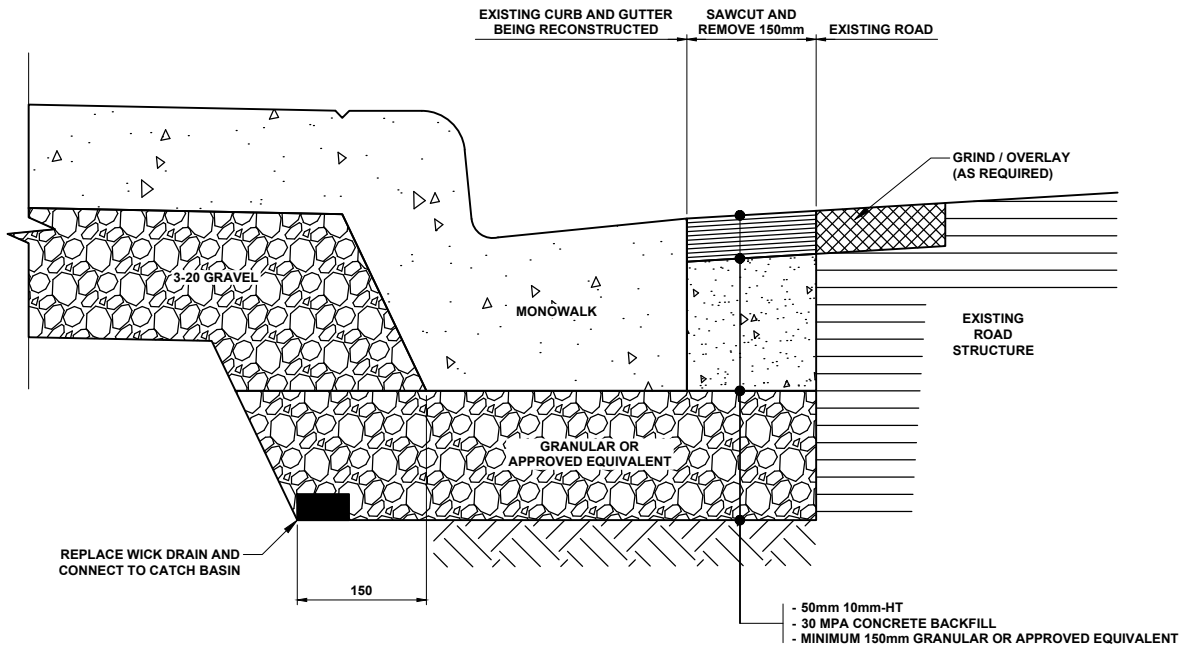

MONOWALK REPLACEMENT

**ALL DIMENSIONS
IN METRES UNLESS
OTHERWISE NOTED**

STANDARD DRAWING

**CURB AND GUTTER / MONOWALK REPLACEMENT
SAWCUT DETAILS**

DATE APPROVED: **2025**
SCALE: **N.T.S.**

DRAWN BY: **FR**
CHECKED BY: **JN**

APPROVED: *[Signature]*

DRAWING NUMBER: **1030**



Standard Drawings

SECTION 2000 – CROSS-SECTIONS

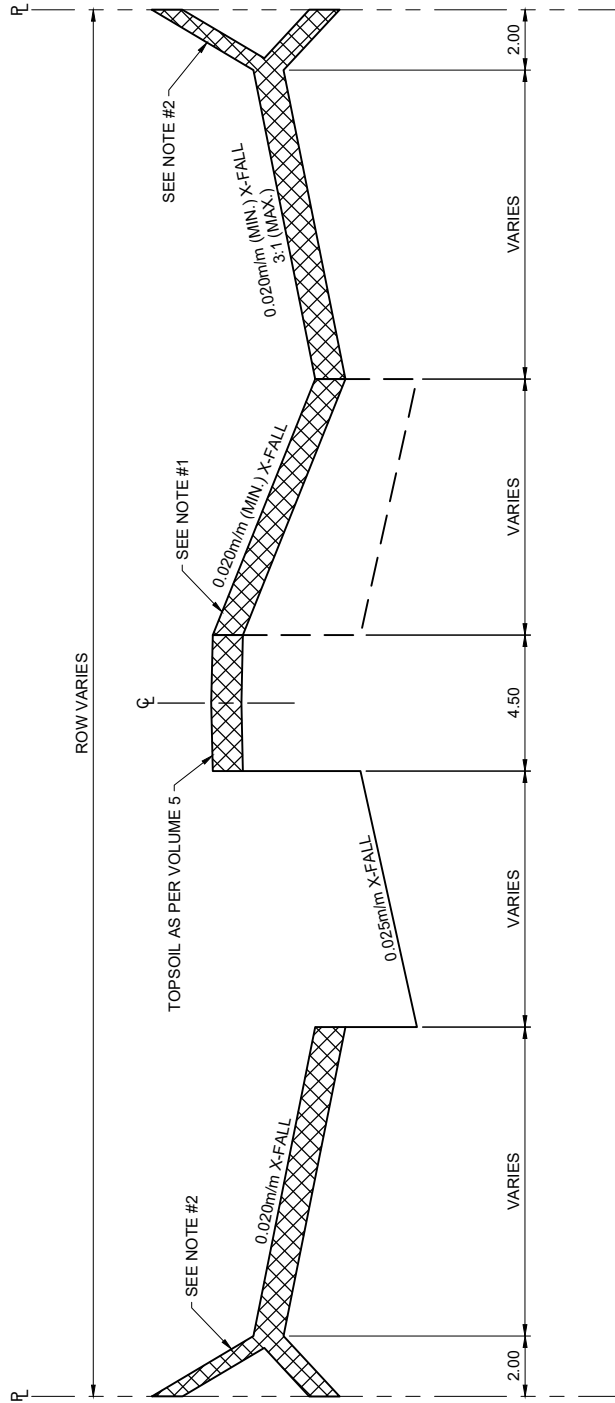

**ALL DIMENSIONS
IN METRES UNLESS
OTHERWISE NOTED**

NOTE:
 1. WHERE ONLY ONE HALF OF THE ARTERIAL ROADWAY IS TO BE CONSTRUCTED AND THE COMPLETE RIGHT OF WAY EXISTS, THE UNCONSTRUCTED PORTION SHALL BE GRADED TO THIS LINE AND DRAINAGE INSTALLED.
 2. GRADE TO MEET THE EXISTING GROUND, IF THE CUT IS IN EXCESS OF 2.00m, SPECIAL GRADES WILL BE SET.



STANDARD DRAWING

STAGED ARTERIAL GRADING REQUIREMENTS

DATE APPROVED: **2025**

DRAWN BY: **FR**

APPROVED:

DRAWING NUMBER: **2020**

SCALE: **N.T.S.**

CHECKED BY: **JN**

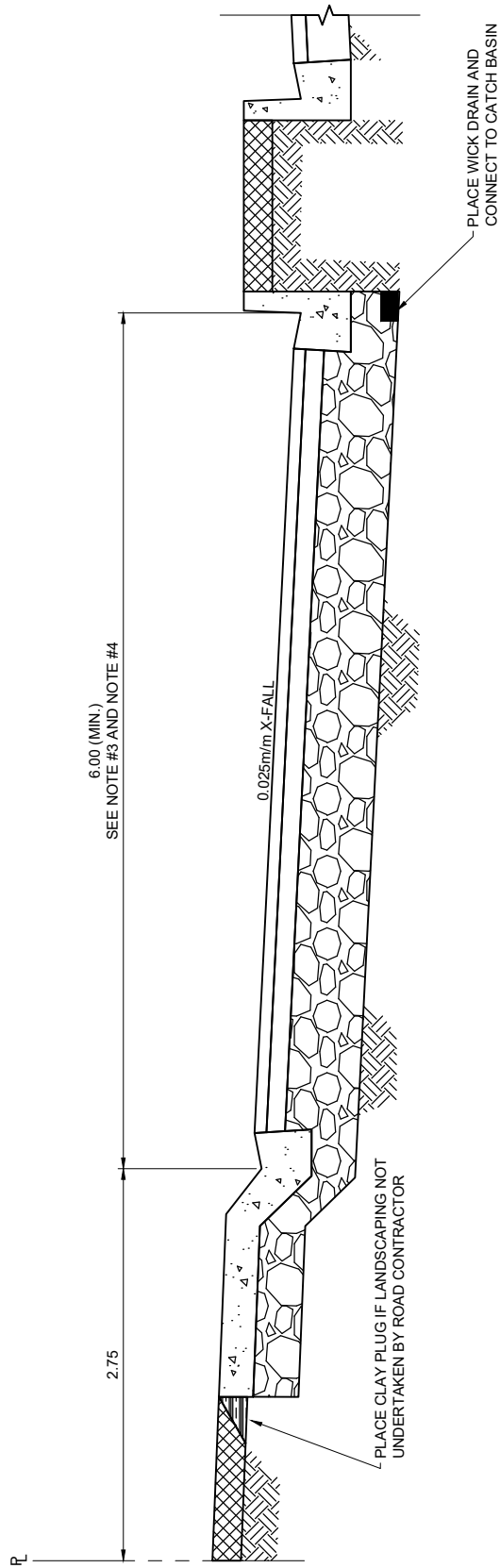

COMPLETE PAVING

NOTE:

1. PAVEMENT STRUCTURE TO BE APPROVED BY CITY OF EDMONTON.
2. X-FALL TO BE MEASURED FROM LIP OF GUTTER.
3. 7.00m FOR FLANKAGE ON RESIDENTIAL LOTS.
4. 8.40m FOR FRONTING ON RESIDENTIAL LOTS.
5. PLACE CLAY PLUG IF LANDSCAPING NOT UNDERTAKEN BY ROAD CONTRACTOR.

ALL DIMENSIONS
IN METRES UNLESS
OTHERWISE NOTED

RESIDENTIAL SERVICE ROAD



STANDARD DRAWING

DATE APPROVED: **2025**

DRAWN BY: **FR**

APPROVED: *[Signature]*

DRAWING NUMBER: **2030**

SCALE: **N.T.S.**

CHECKED BY: **JN**

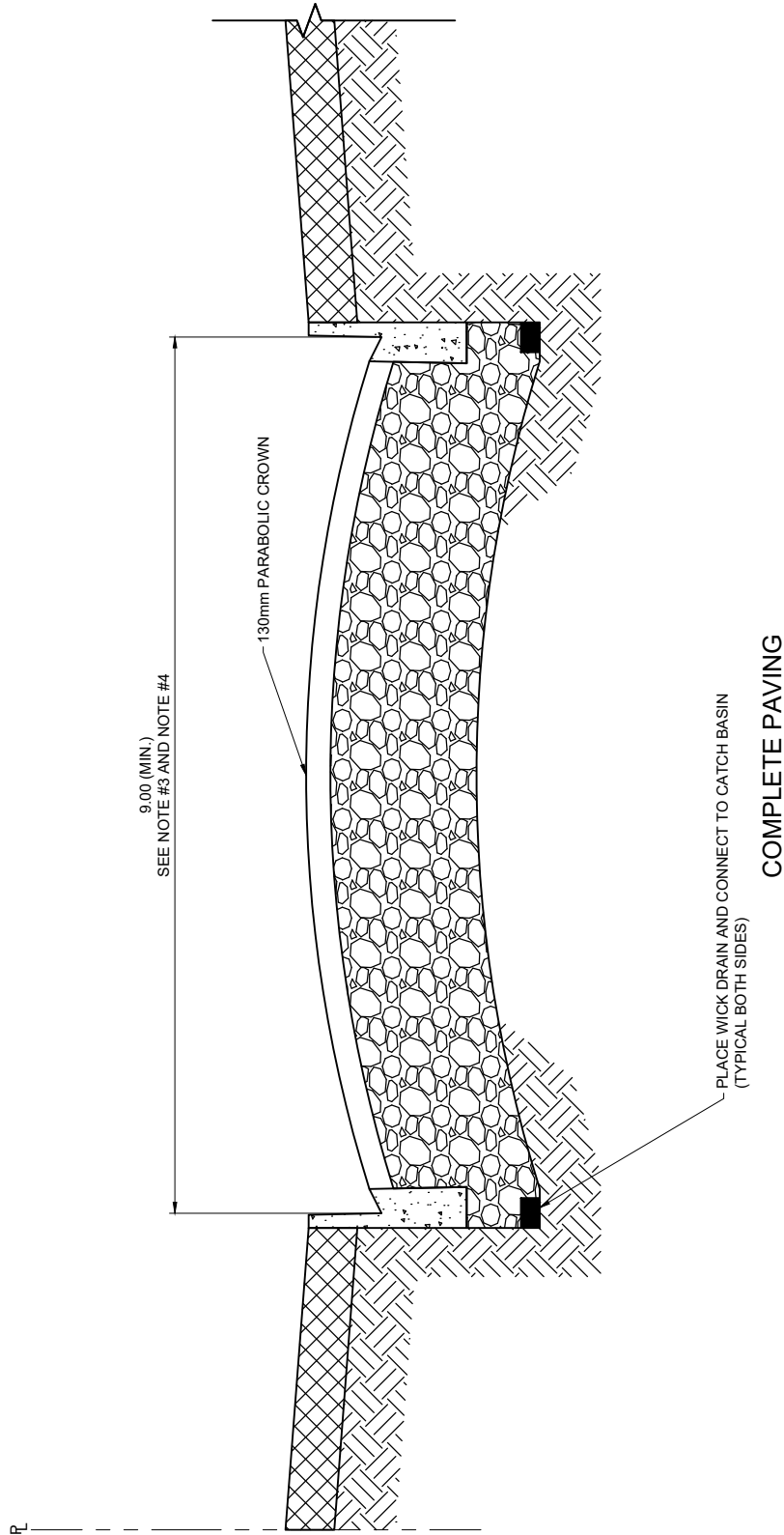

**ALL DIMENSIONS
IN METRES UNLESS
OTHERWISE NOTED**

- NOTE:
1. PAVEMENT STRUCTURE TO BE APPROVED BY CITY OF EDMONTON.
 2. CROWN TO BE MEASURED FROM LIP OF GUTTER.
 3. 9.00m FOR FLANKAGE ON RESIDENTIAL LOTS.
 4. 10.50m FOR FRONTING ON RESIDENTIAL LOTS.

STANDARD DRAWING

INDUSTRIAL SERVICE ROAD

DATE APPROVED: **2025**
SCALE: **N.T.S.**

DRAWN BY: **FR**
CHECKED BY: **JN**

APPROVED: *[Signature]*

DRAWING NUMBER: **2031**

UNSTAGED ASPHALT PAVEMENT		MINIMUM THICKNESS (mm)	
MATERIAL	CENTER	EDGE	
ASPHALT - 10mm-LT (SINGLE LIFT) ¹	100	100	
GRANULAR BASE COURSE - DES 3 CLASS 20 (2 LIFTS) ^{2,3}	225	300	
ALTERNATE GRANULAR BASE COURSE - DES 3 CLASS 20 (TOP LIFT) ³ - DES 3 CLASS 63 (BOTTOM LIFT) ²	125	125	
	150	225	

STAGED ASPHALT PAVEMENT		MINIMUM THICKNESS (mm)	
MATERIAL	CENTER	EDGE	
ASPHALT - 10mm-LT (FINAL LIFT)	35	35	
ASPHALT - 10mm-LT (FIRST LIFT)	65	65	
GRANULAR BASE COURSE - DES 3 CLASS 20 (2 LIFTS) ^{2,3}	225	300	
ALTERNATE GRANULAR BASE COURSE - DES 3 CLASS 20 (TOP LIFT) ³ - DES 3 CLASS 63 (BOTTOM LIFT) ²	125	125	
	150	225	

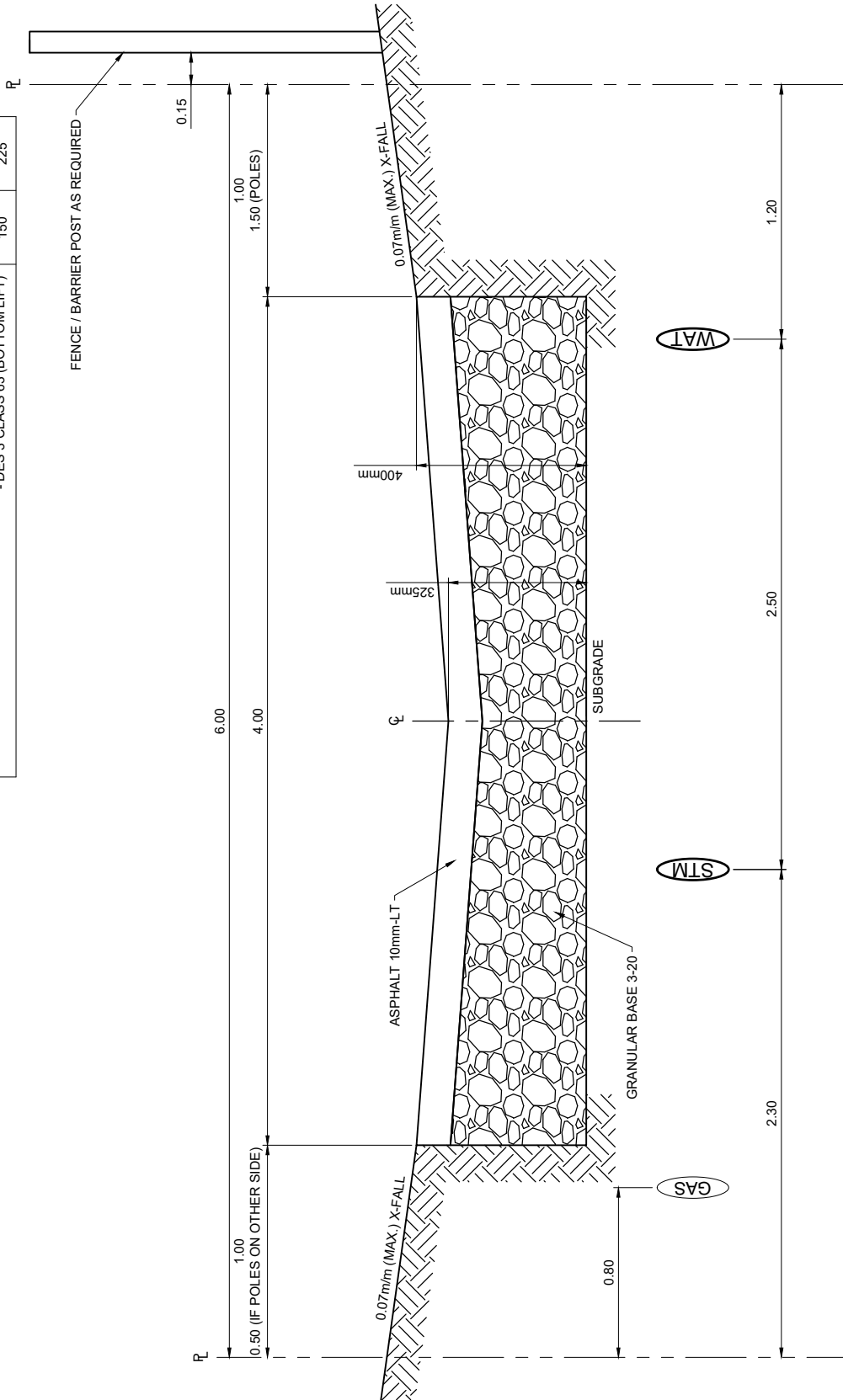

- NOTE:
- 10mm-LT PLACEMENT IN A SINGLE 100mm LIFT IS RESTRICTED TO ALLEY PAVING.
 - ON TOP OF PREPARED SUBGRADE AND NON-WOVEN GEOTEXTILE OR CEMENT STABILIZED SUBGRADE
 - REDUCE CENTRELINE "V" BY 50.00mm AT TIE-IN TO BACK OF BOULEVARD WALK TO FACILITATE DRAINAGE AS REQUIRED.
 - DEPTH OF GAS TRENCH TO BE MINIMUM 1.10m.
 - EDGES OF PAVEMENT TO BE WARPED TO FIT DRIVEWAYS.
 - ALLEY IS CENTERED IN ROW UNLESS THERE ARE POLES.

**ALL DIMENSIONS
IN METRES UNLESS
OTHERWISE NOTED**

STANDARD DRAWING

4.00m RESIDENTIAL ALLEY

DATE APPROVED: 2025	DRAWN BY: FR	APPROVED: 	DRAWING NUMBER: 2040
SCALE: N.T.S.	CHECKED BY: JN		

UNSTAGED ASPHALT PAVEMENT	MATERIAL	MINIMUM THICKNESS (mm)	
		CENTER	EDGE
ASPHALT - 10mm-LT (SURFACE LIFT)		50	50
ASPHALT - 20mm-B (BOTTOM LIFT)		75	75
GRANULAR BASE COURSE - DES 3 CLASS 20 (2 LIFTS) ^{1/2}		300	375
ALTERNATE GRANULAR BASE COURSE - DES 3 CLASS 20 (TOP LIFT) ^{1/2} - DES 3 CLASS 63 (BOTTOM LIFT)		150	150
		150	225

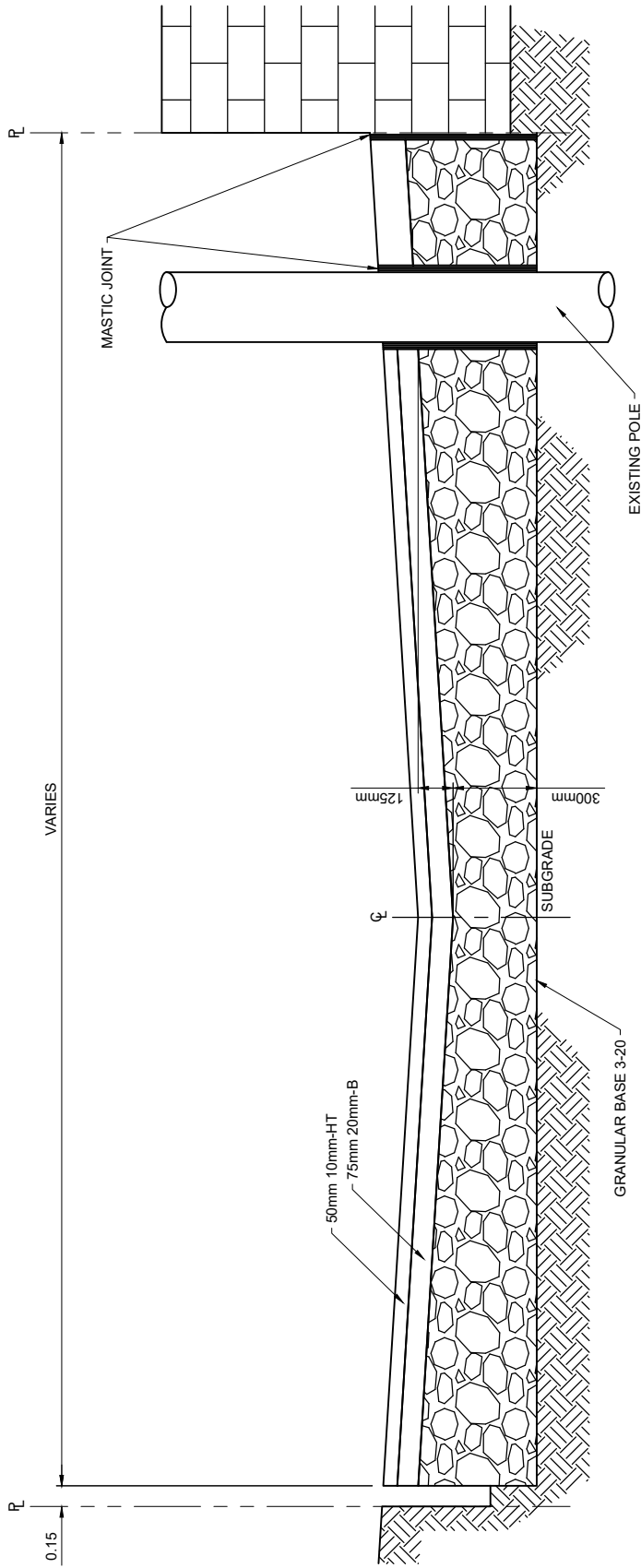

NOTE:

1. ATOP PREPARED SUBGRADE AND NON-WOVEN GEOTEXTILE OR CEMENT STABILIZED SUBGRADE.
2. REDUCE CENTRELINE "V" BY 50mm AT TIE-IN TO BACK OF BOULEVARD WALK TO FACILITATE DRAINAGE AS REQUIRED.
3. IN ALLEY CONSTRUCTION, THE SAG POINT MAY BE OFF CENTERED AND / OR THE CROSS-FALL VARIED TO MATCH EXISTING GRADES ALONG THE ALLEY EDGES.
4. EXCAVATION LIMITS TO BE AS SHOWN ABOVE.

**ALL DIMENSIONS
IN METRES UNLESS
OTHERWISE NOTED**

6.00m COMMERCIAL ALLEY



STANDARD DRAWING

DATE APPROVED: **2025**

DRAWN BY: **FR**

APPROVED: *[Signature]*

DRAWING NUMBER: **2041**

SCALE: **N.T.S.**

CHECKED BY: **JN**

UNSTAGED ASPHALT PAVEMENT		STAGED ASPHALT PAVEMENT	
MATERIAL	MINIMUM THICKNESS (mm)	MATERIAL	MINIMUM THICKNESS (mm)
CENTER	EDGE	CENTER	EDGE
ASPHALT - 10mm-LT (SINGLE LIFT) ¹	100	ASPHALT - 10mm-LT (FINAL LIFT)	35
GRANULAR BASE COURSE - DES 3 CLASS 20 (2 LIFTS) ^{2,3}	225	ASPHALT - 10mm-LT (FIRST LIFT)	65
ALTERNATE GRANULAR BASE COURSE - DES 3 CLASS 20 (TOP LIFT) ³	125	GRANULAR BASE COURSE - DES 3 CLASS 20 (2 LIFTS) ^{2,3}	300
- DES 3 CLASS 63 (BOTTOM LIFT) ²	150	ALTERNATE GRANULAR BASE COURSE - DES 3 CLASS 20 (TOP LIFT) ³	125
		- DES 3 CLASS 63 (BOTTOM LIFT) ²	225

UNSTAGED ASPHALT PAVEMENT		STAGED ASPHALT PAVEMENT	
MATERIAL	MINIMUM THICKNESS (mm)	MATERIAL	MINIMUM THICKNESS (mm)
CENTER	EDGE	CENTER	EDGE
ASPHALT - 10mm-LT (SINGLE LIFT) ¹	100	ASPHALT - 10mm-LT (FINAL LIFT)	35
GRANULAR BASE COURSE - DES 3 CLASS 20 (2 LIFTS) ^{2,3}	225	ASPHALT - 10mm-LT (FIRST LIFT)	65
ALTERNATE GRANULAR BASE COURSE - DES 3 CLASS 20 (TOP LIFT) ³	125	GRANULAR BASE COURSE - DES 3 CLASS 20 (2 LIFTS) ^{2,3}	300
- DES 3 CLASS 63 (BOTTOM LIFT) ²	150	ALTERNATE GRANULAR BASE COURSE - DES 3 CLASS 20 (TOP LIFT) ³	125
		- DES 3 CLASS 63 (BOTTOM LIFT) ²	225

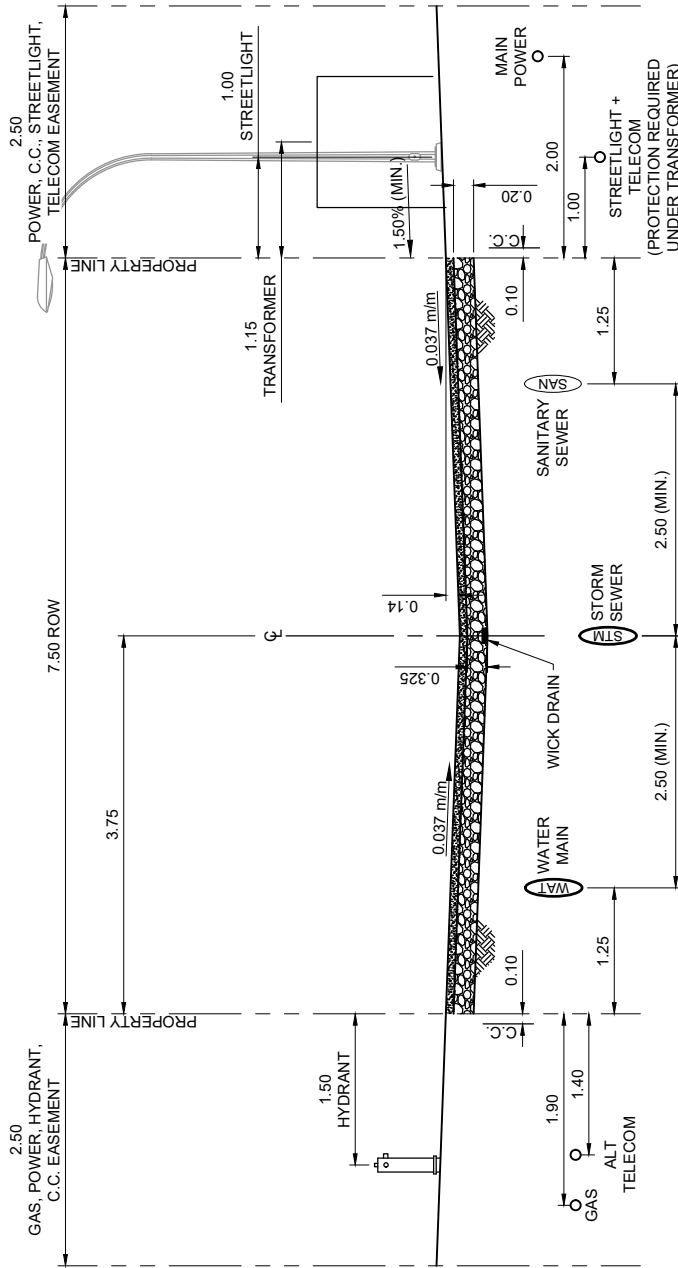

**ALL DIMENSIONS
IN METRES UNLESS
OTHERWISE NOTED**

- NOTE:
- EDGE OF PAVEMENT TO BE WRAPPED TO MATCH DRIVEWAY.
 - REDUCE CENTERLINE "V" TO 50mm AT TIE-IN TO BACK OF BOULEVARD WALK TO FACILITATE DRAINAGE AS REQUIRED.

STANDARD DRAWING

RESIDENTIAL REVERSE HOUSING ALLEY - 7.50m ROW

DATE APPROVED: 2025	DRAWN BY: FR	APPROVED: 	DRAWING NUMBER: 2042
SCALE: N.T.S.	CHECKED BY: JN		

UNSTAGED ASPHALT PAVEMENT		STAGED ASPHALT PAVEMENT	
MATERIAL	MINIMUM THICKNESS (mm)	MATERIAL	MINIMUM THICKNESS (mm)
CENTER	EDGE	CENTER	EDGE
ASPHALT - 10mm-LT (SINGLE LIFT) ¹	100	ASPHALT - 10mm-LT (FINAL LIFT)	35
GRANULAR BASE COURSE - DES 3 CLASS 20 (2 LIFTS) ^{2,3}	300	ASPHALT - 10mm-LT (FIRST LIFT)	65
ALTERNATE GRANULAR BASE COURSE - DES 3 CLASS 20 (TOP LIFT) ³ - DES 3 CLASS 63 (BOTTOM LIFT) ²	125 150	GRANULAR BASE COURSE - DES 3 CLASS 20 (2 LIFTS) ^{2,3}	225
	225	ALTERNATE GRANULAR BASE COURSE - DES 3 CLASS 20 (TOP LIFT) ³ - DES 3 CLASS 63 (BOTTOM LIFT) ²	125 150

UNSTAGED ASPHALT PAVEMENT		STAGED ASPHALT PAVEMENT	
MATERIAL	MINIMUM THICKNESS (mm)	MATERIAL	MINIMUM THICKNESS (mm)
CENTER	EDGE	CENTER	EDGE
ASPHALT - 10mm-LT (SINGLE LIFT) ¹	100	ASPHALT - 10mm-LT (FINAL LIFT)	35
GRANULAR BASE COURSE - DES 3 CLASS 20 (2 LIFTS) ^{2,3}	300	ASPHALT - 10mm-LT (FIRST LIFT)	65
ALTERNATE GRANULAR BASE COURSE - DES 3 CLASS 20 (TOP LIFT) ³ - DES 3 CLASS 63 (BOTTOM LIFT) ²	125 150	GRANULAR BASE COURSE - DES 3 CLASS 20 (2 LIFTS) ^{2,3}	225
	225	ALTERNATE GRANULAR BASE COURSE - DES 3 CLASS 20 (TOP LIFT) ³ - DES 3 CLASS 63 (BOTTOM LIFT) ²	125 150

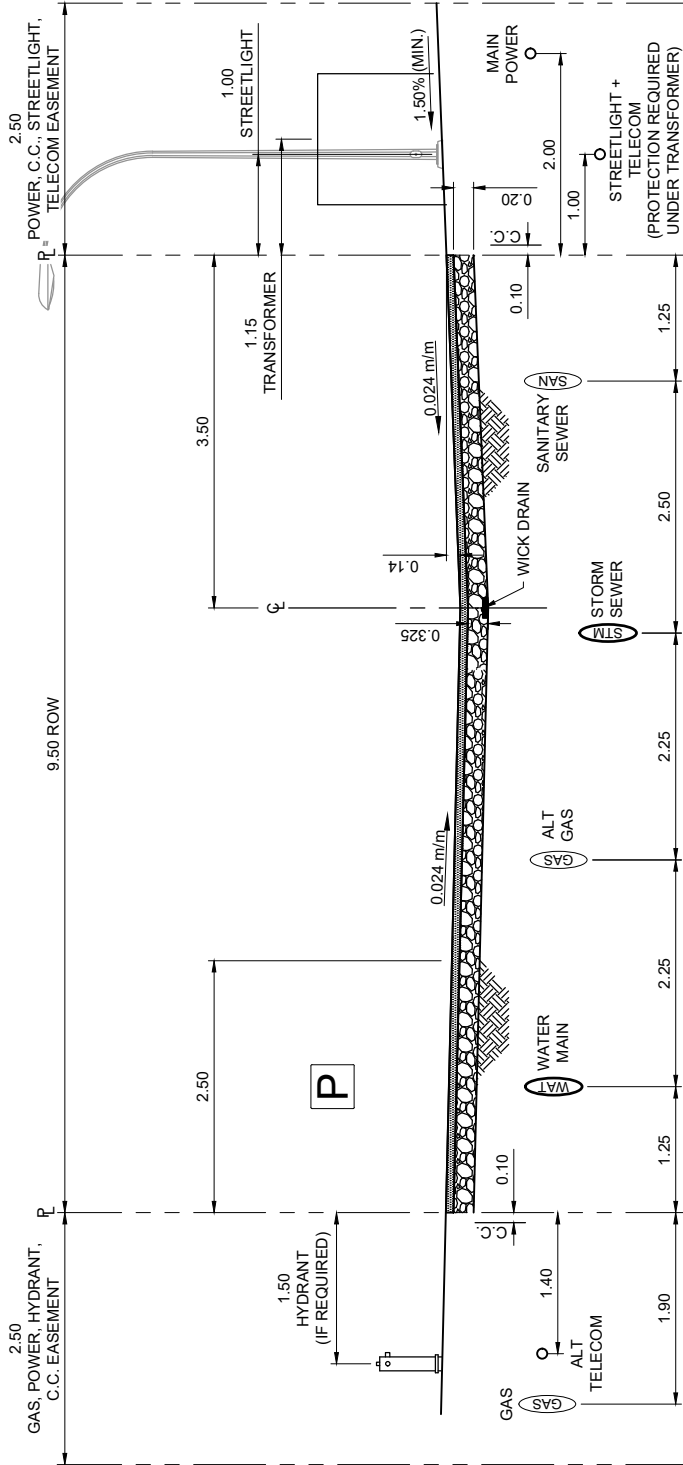

LEGEND:



NOTE:

- EDGE OF PAVEMENT TO BE WRAPPED TO MATCH DRIVEWAY.
- REDUCE CENTERLINE "V" TO 50mm AT TIE-IN TO BACK OF BOULEVARD WALK TO FACILITATE DRAINAGE AS REQUIRED.

ALL DIMENSIONS
IN METRES UNLESS
OTHERWISE NOTED



REVERSE HOUSING ALLEY WITH PARKING - 9.50m ROW

DATE APPROVED: **2025**
SCALE: **N.T.S.**

DRAWN BY: **FR**
CHECKED BY: **JN**

APPROVED: *[Signature]*

DRAWING NUMBER: **2043**

UNSTAGED ASPHALT PAVEMENT		MINIMUM THICKNESS (mm)	
MATERIAL	EDGE	CENTER	EDGE
ASPHALT - 10mm-LT (SINGLE LIFT) ¹	100	100	100
GRANULAR BASE COURSE - DES 3 CLASS 20 (2 LIFTS) ^{2,3}	225	225	300
ALTERNATE GRANULAR BASE COURSE - DES 3 CLASS 20 (TOP LIFT) ³ - DES 3 CLASS 63 (BOTTOM LIFT) ²	125	125	125
	150	150	225

STAGED ASPHALT PAVEMENT		MINIMUM THICKNESS (mm)	
MATERIAL	EDGE	CENTER	EDGE
ASPHALT - 10mm-LT (FINAL LIFT)	35	35	35
ASPHALT - 10mm-LT (FIRST LIFT)	65	65	65
GRANULAR BASE COURSE - DES 3 CLASS 20 (2 LIFTS) ^{2,3}	225	225	300
ALTERNATE GRANULAR BASE COURSE - DES 3 CLASS 20 (TOP LIFT) ³ - DES 3 CLASS 63 (BOTTOM LIFT) ²	125	125	125
	150	150	225

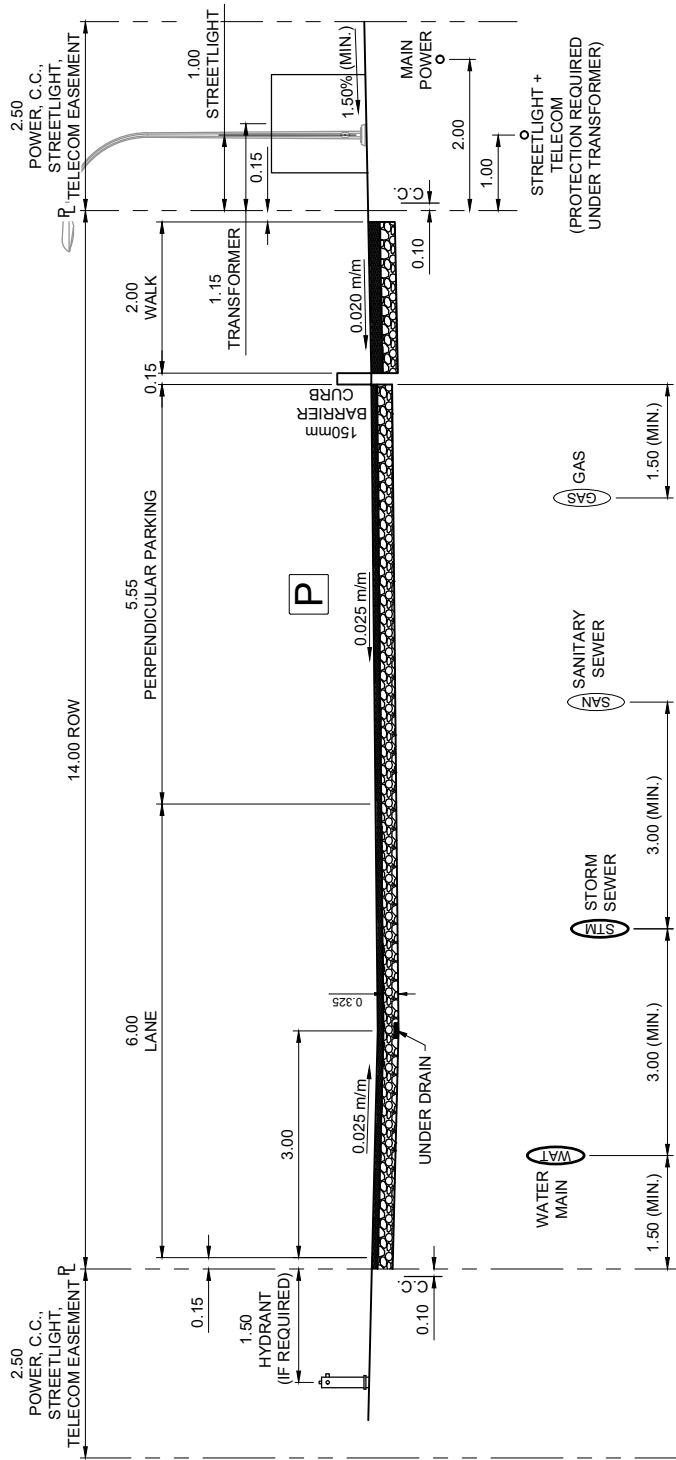

LEGEND:



NOTE:

- EDGE OF PAVEMENT TO BE WARPED TO MATCH DRIVEWAY.
- REDUCE CENTERLINE "V" TO 50mm AT TIE-IN TO BACK OF BOULEVARD WALK TO FACILITATE DRAINAGE AS REQUIRED.

ALL DIMENSIONS
IN METRES UNLESS
OTHERWISE NOTED

STANDARD DRAWING

REVERSE HOUSING ALLEY WITH PERPENDICULAR PARKING AND WALK - 14.00m ROW

DATE APPROVED: **2025**

SCALE: **N.T.S.**

DRAWN BY: **FR**

CHECKED BY: **JN**

APPROVED: *[Signature]*

DRAWING NUMBER: **2044**

ALL DIMENSIONS
IN METRES UNLESS
OTHERWISE NOTED

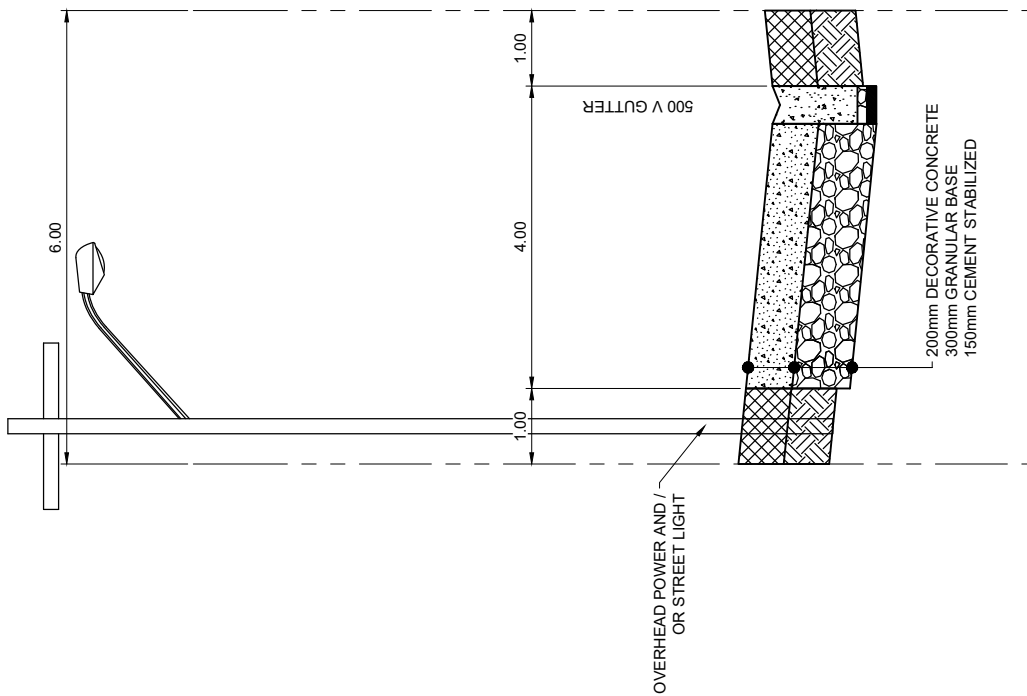

STANDARD DRAWING

RESIDENTIAL SHARED ALLEY - 6.00m ROW

DATE APPROVED: **2025**
SCALE: **N.T.S.**

DRAWN BY: **FR**
CHECKED BY: **JN**

APPROVED: *[Signature]*

DRAWING NUMBER: **2045**

ALL DIMENSIONS
IN METRES UNLESS
OTHERWISE NOTED

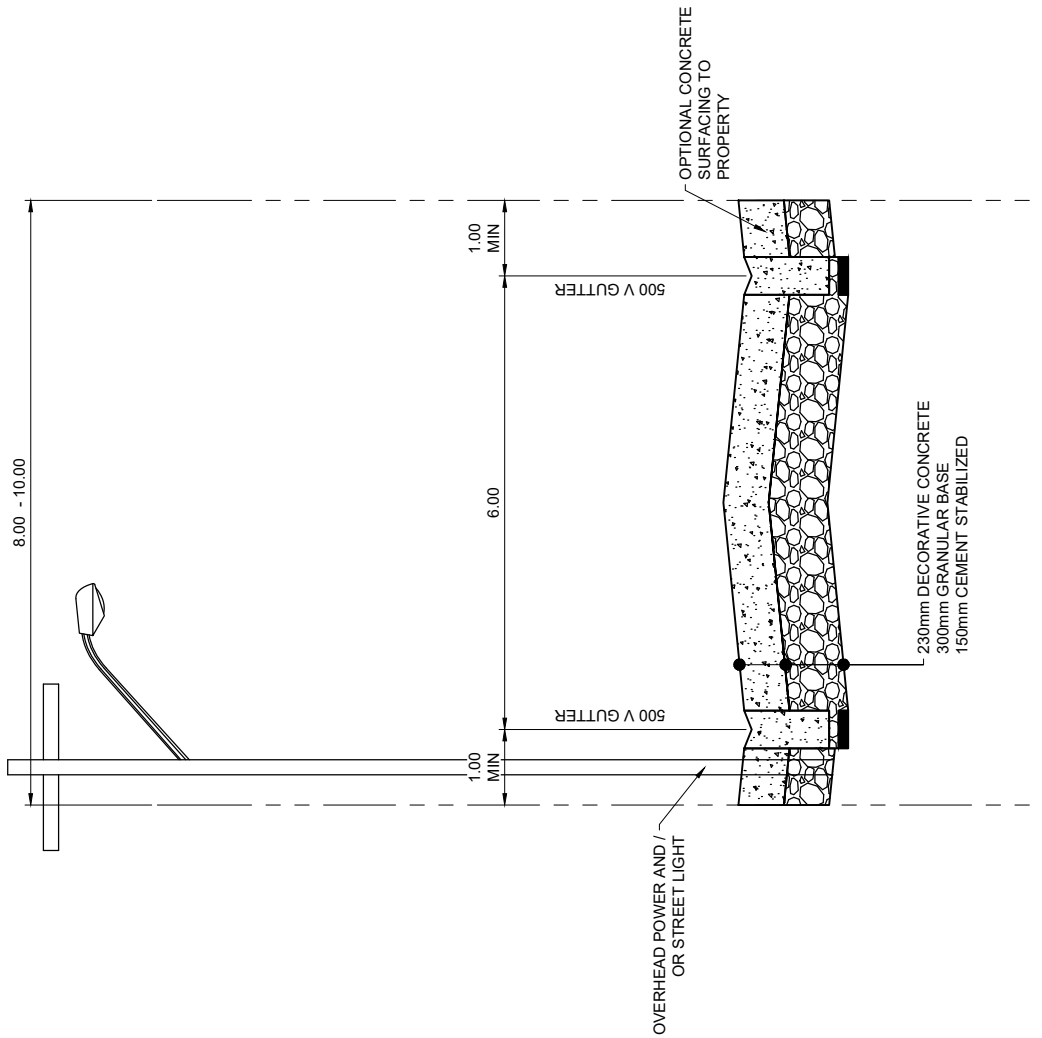

STANDARD DRAWING

COMMERCIAL SHARED ALLEY - 8.00m - 10.00m ROW

DATE APPROVED: **2025**

SCALE: **N.T.S.**

DRAWN BY: **FR**

CHECKED BY: **JN**

APPROVED: 

DRAWING NUMBER: **2046**

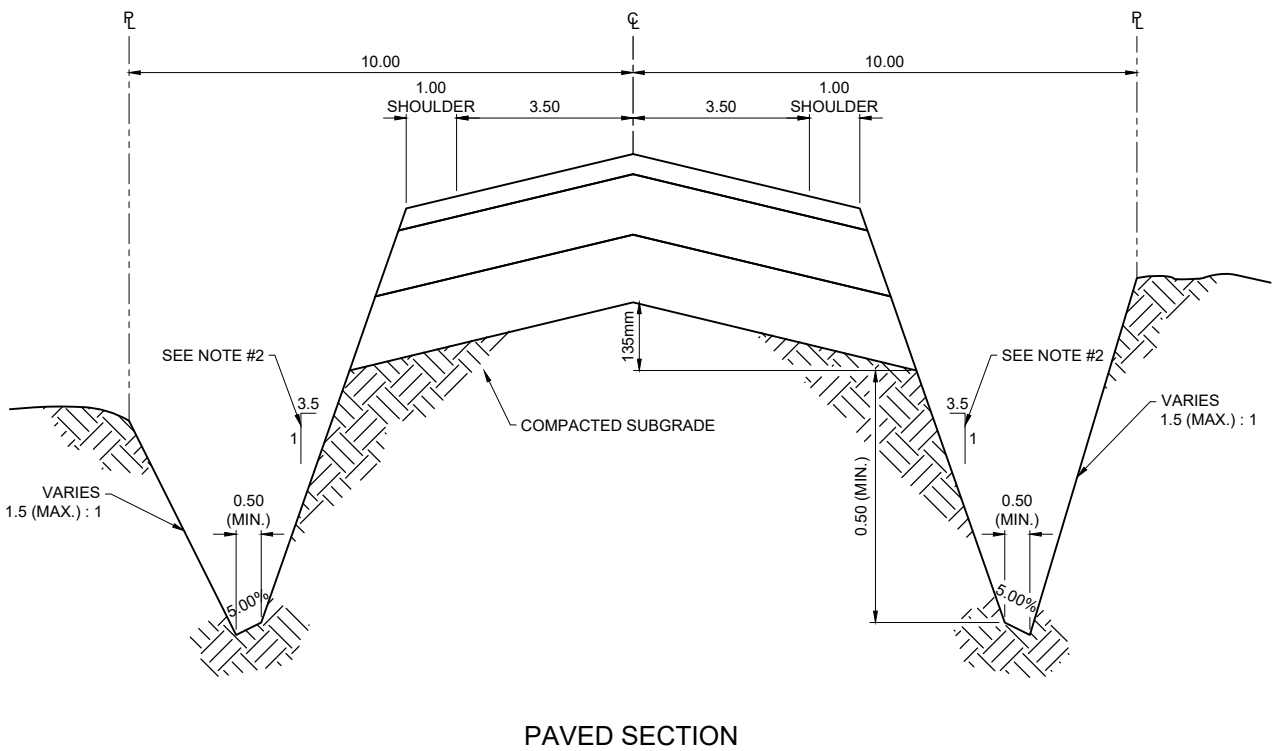
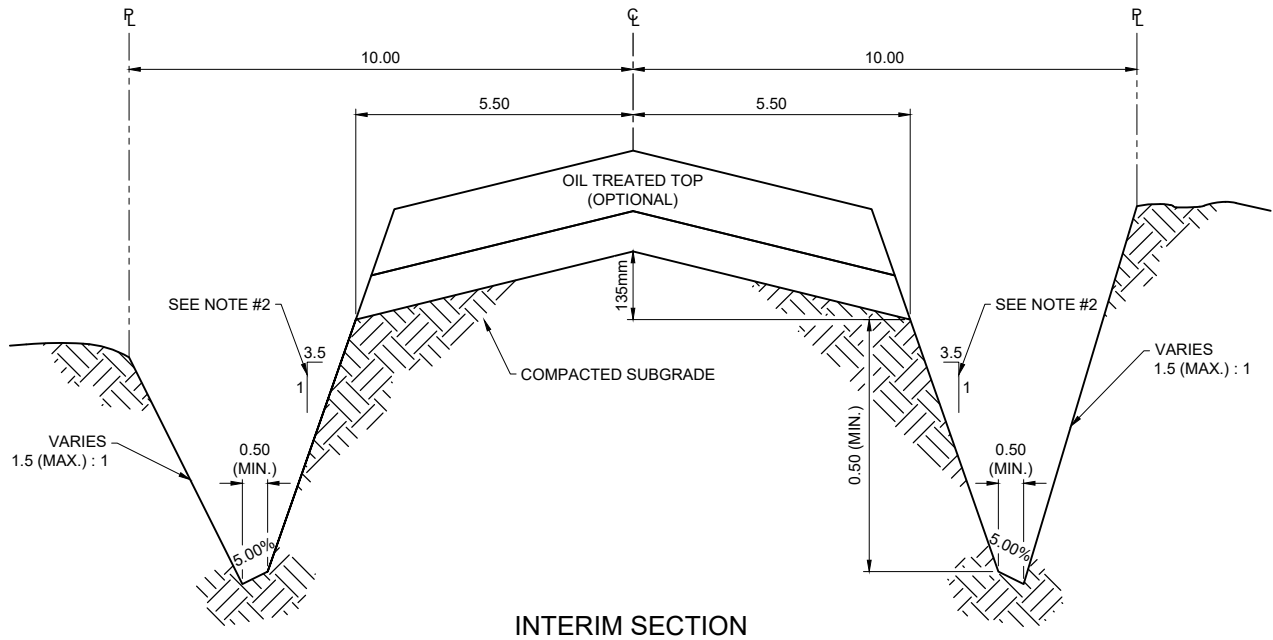

NOTE:

1. GEOTEXTILE TO BE PLACED BETWEEN SUBGRADE AND BASE WHEN A WET SUBGRADE IS ENCOUNTERED, AS DIRECTED BY THE ENGINEER.
2. SIDESLOPE DEPENDS ON DESIGN SPEED AND TRAFFIC VOLUME, REFER TO TAC GUIDELINES.
3. REVIEW GEOTECHNICAL AND STABILITY TO DETERMINE REQUIREMENT FOR GUARDRAILS, REFER TO TAC GUIDELINES.
4. PAVEMENT STRUCTURE TO BE DETERMINED BASED ON GEOTECHNICAL REVIEW AND SATISFACTION OF CITY OF EDMONTON STANDARD.

**ALL DIMENSIONS
IN METRES UNLESS
OTHERWISE NOTED**



STANDARD DRAWING

9.0m RURAL LOCAL / COLLECTOR ROADWAY

DATE APPROVED: **2025**

SCALE: **N.T.S.**

DRAWN BY: **FR**

CHECKED BY: **JN**

APPROVED: 

DRAWING NUMBER: **2050**

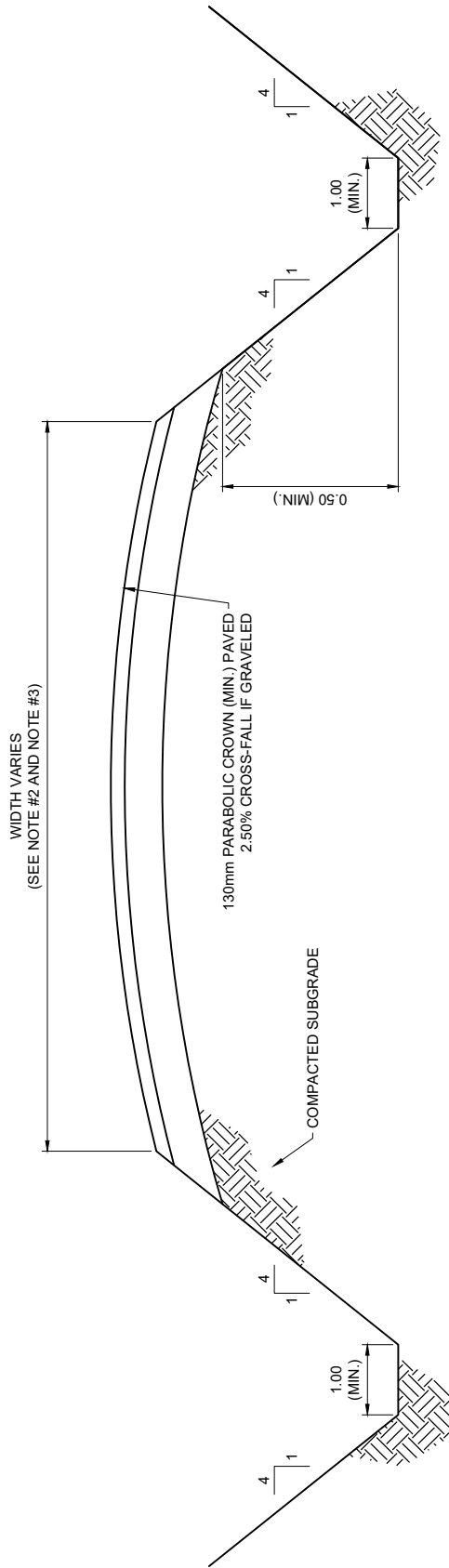

**ALL DIMENSIONS
IN METRES UNLESS
OTHERWISE NOTED**

NOTE:

1. GEOTEXTILE FABRIC TO BE PLACED ON SUBGRADE, AS DIRECTED BY THE ENGINEER.
2. MINIMUM WIDTH FOR TWO-LANE OPERATIONS IS 6.00m FOR TEMPORARY ACCESS AND 7.00m FOR DETOUR ROAD.
3. MINIMUM WIDTH FOR ONE-LANE OPERATIONS IS 3.00m FOR TEMPORARY ACCESS AND 3.50m FOR DETOUR ROAD.
4. PAVEMENT STRUCTURE TO BE DETERMINED BASED ON GEOTECHNICAL REVIEW AND SATISFACTION OF CITY OF EDMONTON STANDARD.
5. BACKSLOPE ARE SUBJECT TO GEOTECHNICAL REPORT AND RIGHT-OF-WAY ALLOWANCE.

TEMPORARY ACCESS / DETOUR ROAD



STANDARD DRAWING

DATE APPROVED: **2025**

DRAWN BY: **FR**

APPROVED: *[Signature]*

DRAWING NUMBER: **2060**

SCALE: **N.T.S.**

CHECKED BY: **JN**

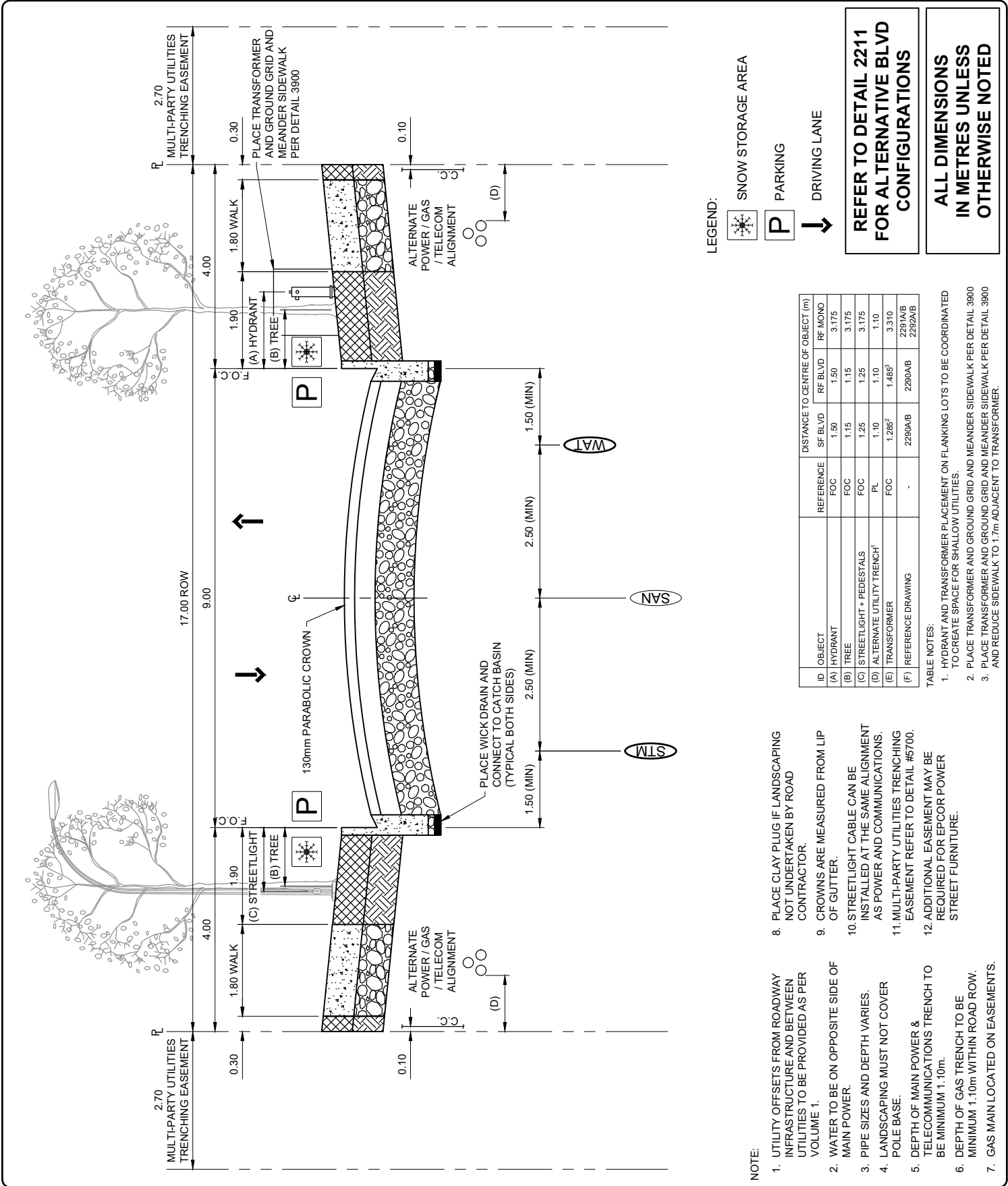

NOTE:

- UTILITY OFFSETS FROM ROADWAY INFRASTRUCTURE AND BETWEEN UTILITIES TO BE PROVIDED AS PER VOLUME 1.
- WATER TO BE ON OPPOSITE SIDE OF MAIN POWER.
- PIPE SIZES AND DEPTH VARIES.
- LANDSCAPING MUST NOT COVER POLE BASE.
- DEPTH OF MAIN POWER & TELECOMMUNICATIONS TRENCH TO BE MINIMUM 1.40m.
- DEPTH OF GAS TRENCH TO BE MINIMUM 1.10m WITHIN ROAD ROW.
- GAS MAIN LOCATED ON EASEMENTS.
- PLACE CLAY PLUG IF LANDSCAPING NOT UNDERTAKEN BY ROAD CONTRACTOR.
- CROWNS ARE MEASURED FROM LIP OF GUTTER.
- STREETLIGHT CABLE CAN BE INSTALLED AT THE SAME ALIGNMENT AS POWER AND COMMUNICATIONS.
- MULTI-PARTY UTILITIES TRENCHING EASEMENT REFER TO DETAIL #6700.
- ADDITIONAL EASEMENT MAY BE REQUIRED FOR EPOR POWER STREET FURNITURE.

ID	OBJECT	REFERENCE	SF BLVD	RF BLVD	RF MONO
(A)	HYDRANT	FOC	1.50	1.50	3.175
(B)	TREE	FOC	1.15	1.15	3.175
(C)	STREETLIGHT + PEDESTALS	FOC	1.25	1.25	3.175
(D)	ALTERNATE UTILITY TRENCH ¹	PL	1.10	1.10	1.10
(E)	TRANSFORMER	FOC	1.285 ²	1.485 ³	3.310
(F)	REFERENCE DRAWING	-	2290A/B	2290A/B	2292A/B

TABLE NOTES:

- HYDRANT AND TRANSFORMER PLACEMENT ON FLANKING LOTS TO BE COORDINATED TO CREATE SPACE FOR SHALLOW UTILITIES.
- PLACE TRANSFORMER AND GROUND GRID AND MEANDER SIDEWALK PER DETAIL 3900
- PLACE TRANSFORMER AND GROUND GRID AND MEANDER SIDEWALK PER DETAIL 3900 AND REDUCE SIDEWALK TO 1.7m ADJACENT TO TRANSFORMER.

REFER TO DETAIL 2211 FOR ALTERNATE BLVD CONFIGURATIONS

ALL DIMENSIONS IN METRES UNLESS OTHERWISE NOTED



9.00m LOCAL RESIDENTIAL (BOULEVARD WALK) - 17.00m ROW

DATE APPROVED: **2025**
SCALE: **N.T.S.**

DRAWN BY: **FR**
CHECKED BY: **JN**

APPROVED: *[Signature]*

DRAWING NUMBER: **2210**

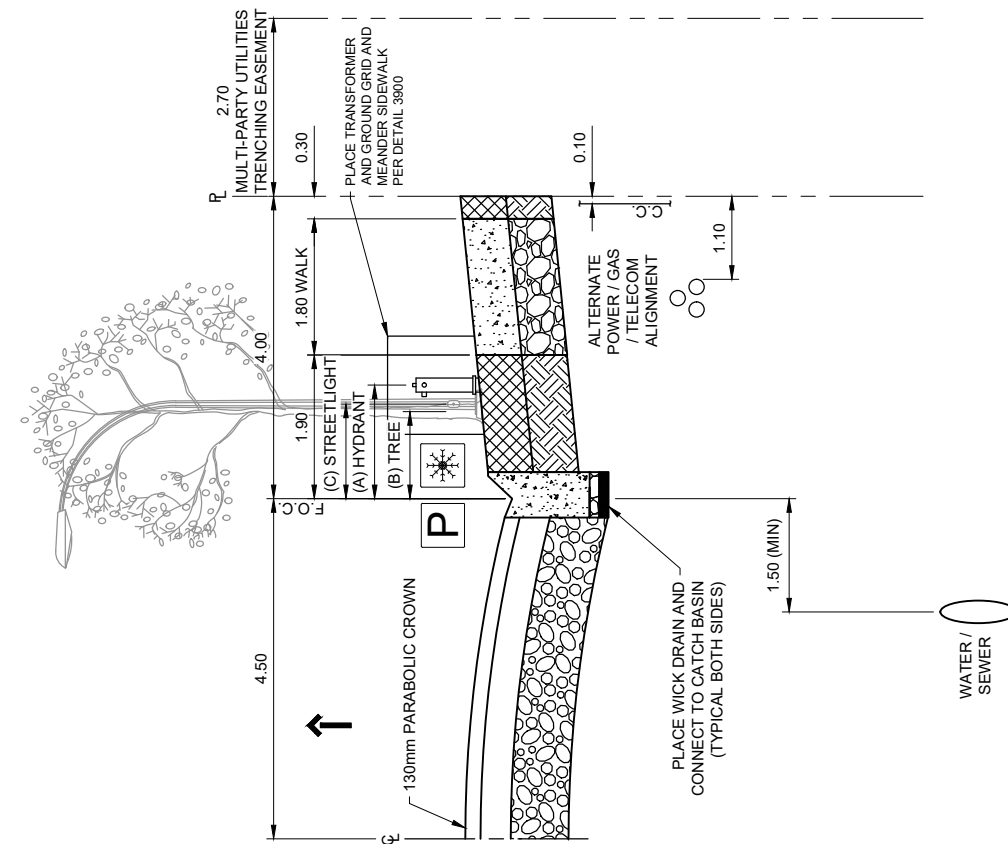
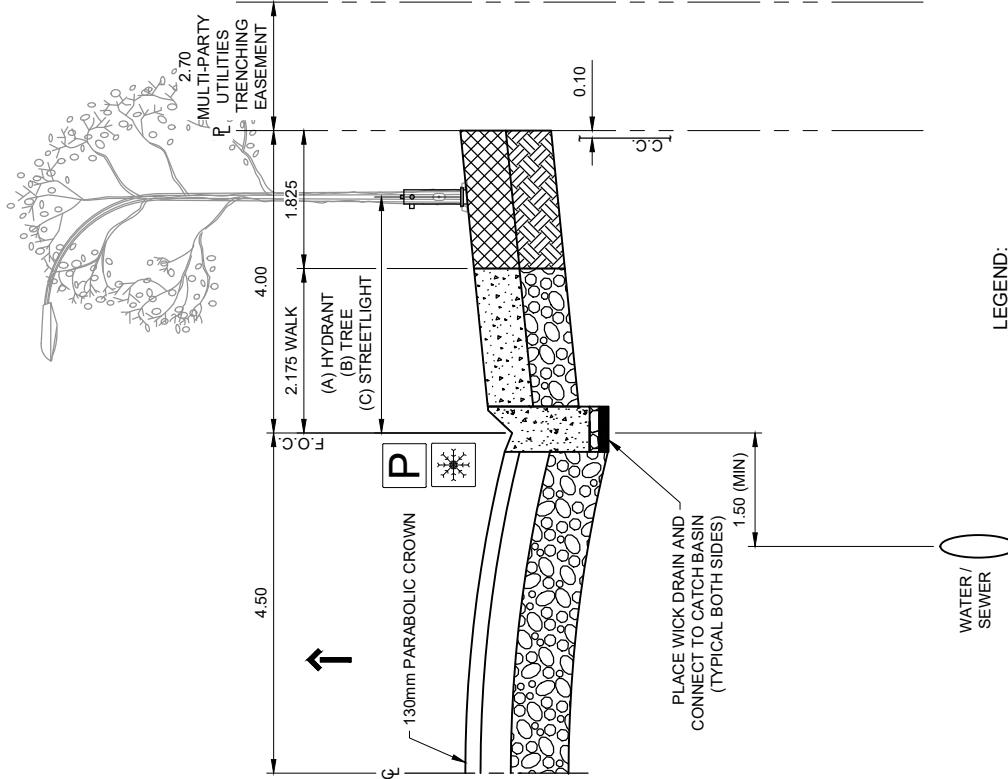

LEGEND:

- SNOW STORAGE AREA
- PARKING
- DRIVING LANE

REFER TO DETAIL 2210 FOR ALTERNATIVE BLVD CONFIGURATIONS

ALL DIMENSIONS IN METRES UNLESS OTHERWISE NOTED

ID / OBJECT	REFERENCE	DISTANCE TO CENTRE OF OBJECT (m)	
		SF BLVD	RF BLVD
(A) HYDRANT	FOC	1.50	1.50
(B) TREE	FOC	1.15	1.15
(C) STREETLIGHT + PEDESTALS	FOC	1.25	1.25
(D) ALTERNATE UTILITY TRENCH	PL	1.10	1.10
(E) TRANSFORMER	FOC	1.285 ²	1.485 ³
(F) REFERENCE DRAWING	-	2290A/B	2291A/B 2292A/B

TABLE NOTES:

1. HYDRANT AND TRANSFORMER PLACEMENT ON FLANKING LOTS TO BE COORDINATED TO CREATE SPACE FOR SHALLOW UTILITIES.
2. PLACE TRANSFORMER AND GROUND GRID AND MEANDER SIDEWALK PER DETAIL 3900
3. PLACE TRANSFORMER AND GROUND GRID AND MEANDER SIDEWALK PER DETAIL 3900 AND REDUCE SIDEWALK TO 1.7m ADJACENT TO TRANSFORMER.



STANDARD DRAWING

9.00m LOCAL RESIDENTIAL (ALTERNATIVE BOULEVARDS) - 17.00m ROW

DATE APPROVED: **2025**

DRAWN BY: **FR**

APPROVED:

DRAWING NUMBER: **2211**

SCALE: **N.T.S.**

CHECKED BY: **JN**

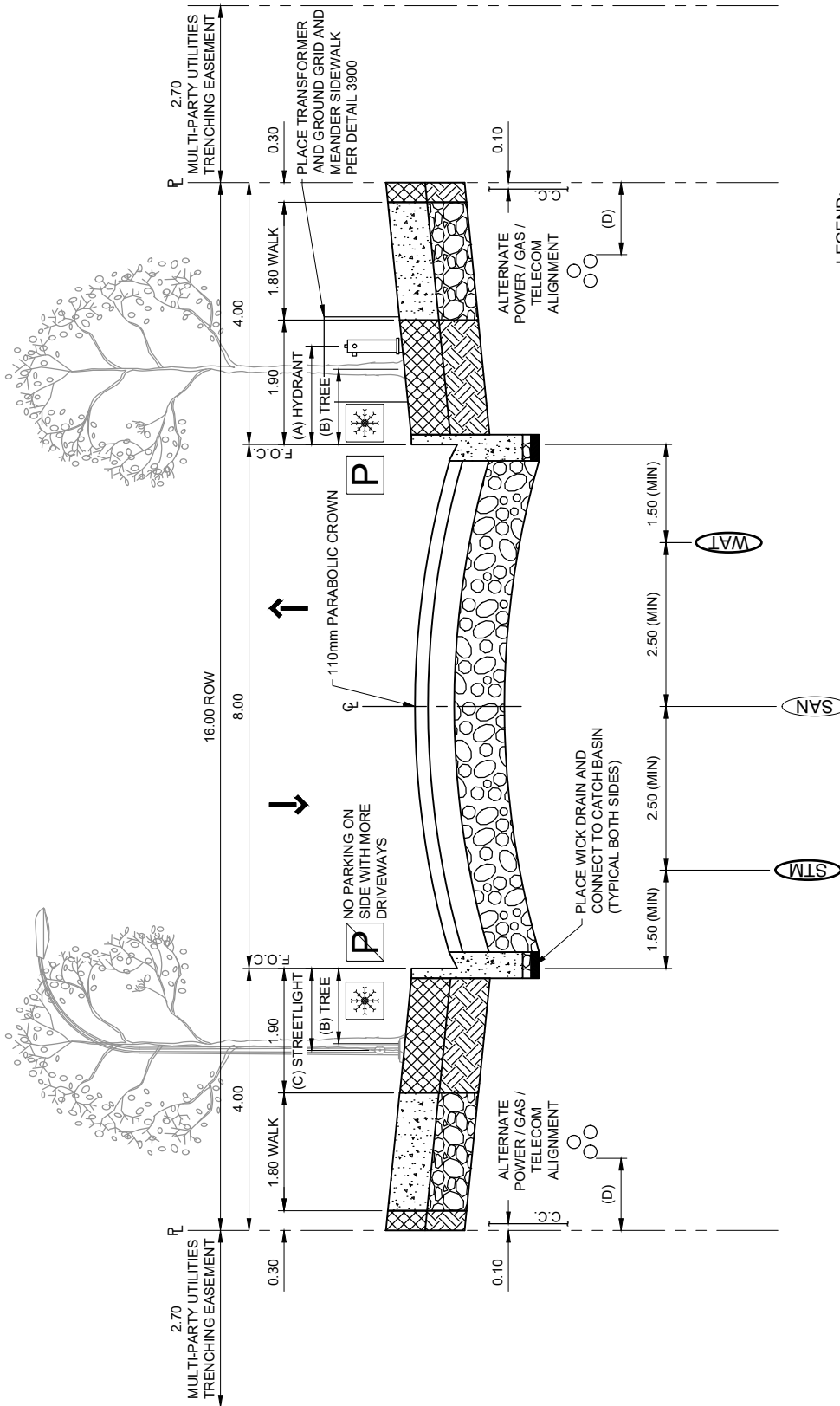

LEGEND:

- SNOW STORAGE AREA
- NO PARKING
- PARKING
- DRIVING LANE

REFER TO DETAIL 2221 FOR ALTERNATE BLVD CONFIGURATIONS

ALL DIMENSIONS IN METRES UNLESS OTHERWISE NOTED

ID	OBJECT	REFERENCE	SF BLVD	RF BLVD	RF MONO
(A)	HYDRANT	FOC	1.50	1.50	3.175
(B)	TREE	FOC	1.15	1.15	3.175
(C)	STREETLIGHT + PEDESTALS	FOC	1.25	1.25	3.175
(D)	ALTERNATE UTILITY TRENCH	PL	1.10	1.10	1.10
(E)	TRANSFORMER	FOC	1.285 ²	1.485 ²	3.310
(F)	REFERENCE DRAWING	-	2290A/B	2290A/B	2291A/B 2292A/B

TABLE NOTES:

1. HYDRANT AND TRANSFORMER PLACEMENT ON FLANKING LOTS TO BE COORDINATED TO CREATE SPACE FOR SHALLOW UTILITIES.
2. PLACE TRANSFORMER AND GROUND GRID AND MEANDER SIDEWALK PER DETAIL 3900
3. PLACE TRANSFORMER AND GROUND GRID AND MEANDER SIDEWALK PER DETAIL 3900 AND REDUCE SIDEWALK TO 1.7m ADJACENT TO TRANSFORMER.

NOTE:

1. UTILITY OFFSETS FROM ROADWAY INFRASTRUCTURE AND BETWEEN UTILITIES TO BE PROVIDED AS PER VOLUME 1.
2. WATER TO BE ON OPPOSITE SIDE OF MAIN POWER.
3. PIPE SIZES AND DEPTH VARIES.
4. LANDSCAPING MUST NOT COVER POLE BASE.
5. DEPTH OF MAIN POWER & TELECOMMUNICATIONS TRENCH TO BE MINIMUM 1.40m.
6. DEPTH OF GAS TRENCH TO BE MINIMUM 1.10m WITHIN ROAD ROW.
7. GAS MAIN LOCATED ON EASEMENTS.
8. PLACE CLAY PLUG IF LANDSCAPING NOT UNDERTAKEN BY ROAD CONTRACTOR.
9. CROWNS ARE MEASURED FROM LIP OF GUTTER.
10. STREETLIGHT CABLE CAN BE INSTALLED AT THE SAME ALIGNMENT AS POWER AND COMMUNICATIONS.
11. MULTI-PARTY UTILITIES TRENCHING EASEMENT REFER TO DETAIL #6700.
12. ADDITIONAL EASEMENT MAY BE REQUIRED FOR EPOR POWER STREET FURNITURE.



8.00m URBAN LOCAL RESIDENTIAL (BOULEVARD WALK) - 16.00m ROW

DATE APPROVED: **2025**
SCALE: **N.T.S.**

DRAWN BY: **FR**
CHECKED BY: **JN**

APPROVED:

DRAWING NUMBER: **2220**

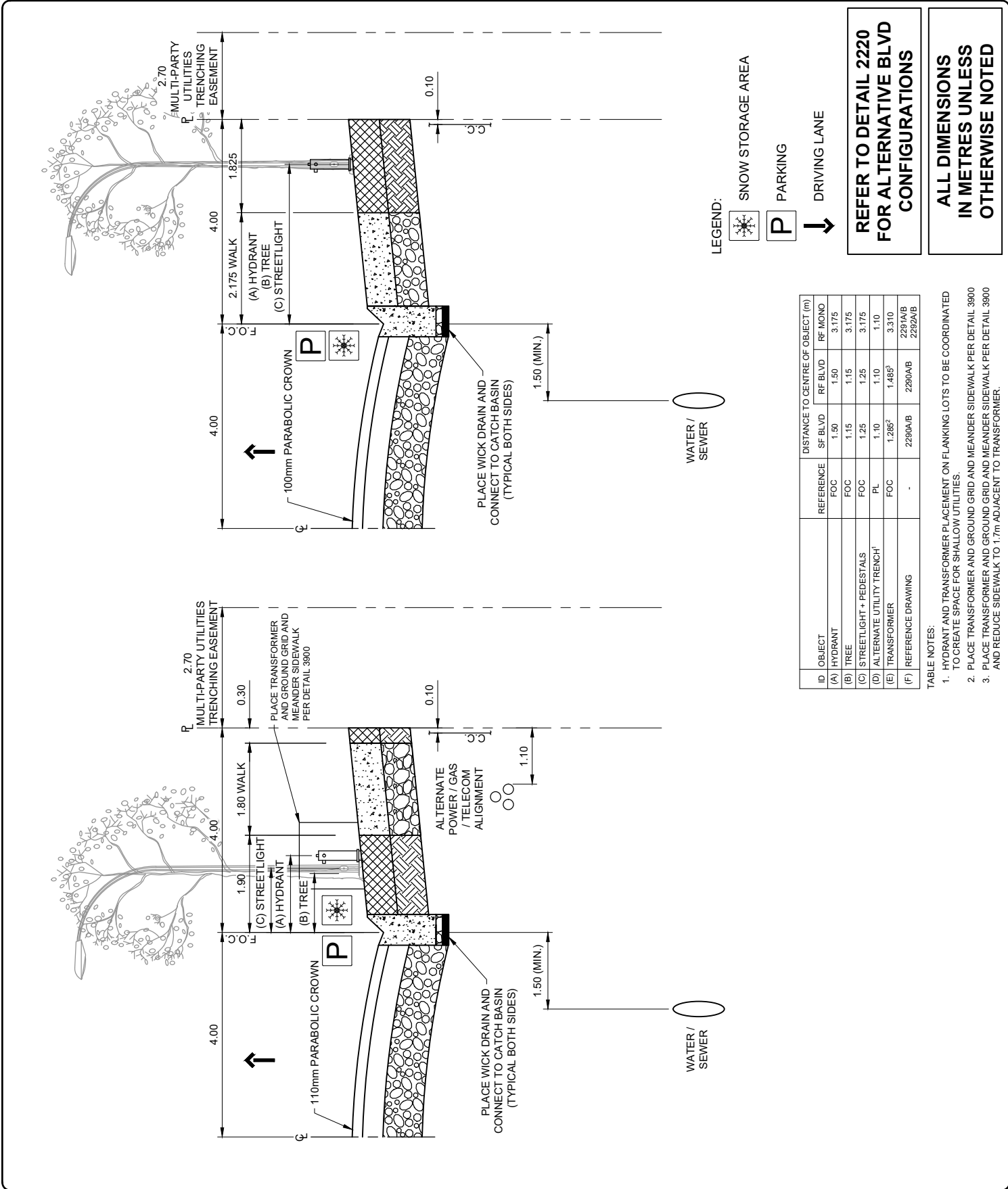

ID / OBJECT	REFERENCE	SF BLVD	RF BLVD	RF MOND
(A) HYDRANT	FOC	1.50	1.50	3.175
(B) TREE	FOC	1.15	1.15	3.175
(C) STREETLIGHT + PEDESTALS	FOC	1.25	1.25	3.175
(D) ALTERNATE UTILITY TRENCH	PL	1.10	1.10	1.10
(E) TRANSFORMER	FOC	1.285 ²	1.485 ³	3.310
(F) REFERENCE DRAWING	-	2290A/B	2290A/B	2291A/B 2292A/B

- TABLE NOTES:
- HYDRANT AND TRANSFORMER PLACEMENT ON FLANKING LOTS TO BE COORDINATED TO CREATE SPACE FOR SHALLOW UTILITIES.
 - PLACE TRANSFORMER AND GROUND GRID AND MEANDER SIDEWALK PER DETAIL 3900
 - PLACE TRANSFORMER AND GROUND GRID AND MEANDER SIDEWALK PER DETAIL 3900 AND REDUCE SIDEWALK TO 1.7m ADJACENT TO TRANSFORMER.

REFER TO DETAIL 2220 FOR ALTERNATIVE BLVD CONFIGURATIONS

ALL DIMENSIONS IN METRES UNLESS OTHERWISE NOTED

STANDARD DRAWING

8.00m LOCAL RESIDENTIAL (ALTERNATIVE BOULEVARDS) - 16.00m ROW

DATE APPROVED: 2025	DRAWN BY: FR	APPROVED: 	DRAWING NUMBER: 2221
SCALE: N.T.S.	CHECKED BY: JN		

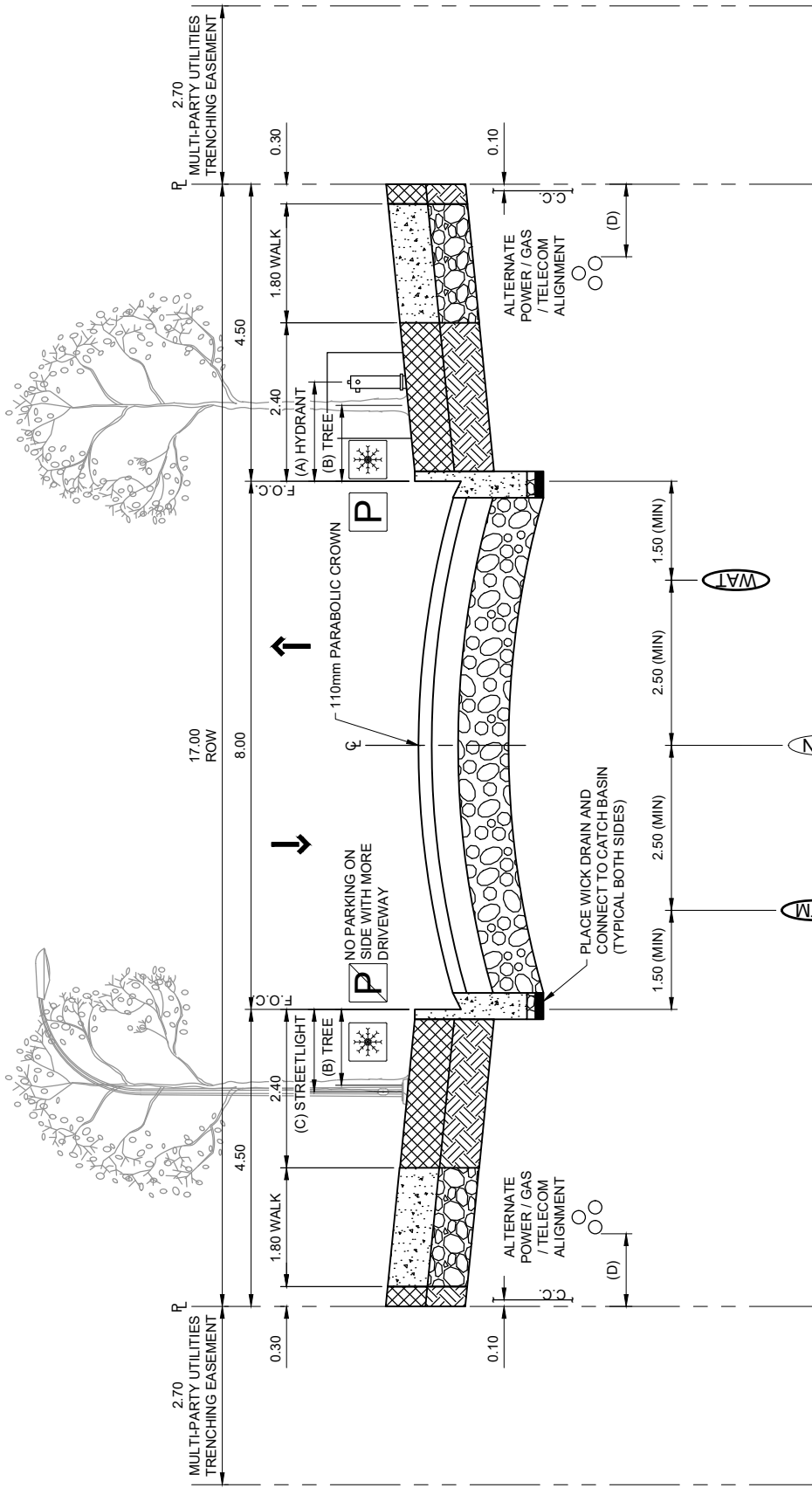

LEGEND:

- SNOW STORAGE AREA
- NO PARKING
- PARKING
- DRIVING LANE

REFER TO DETAIL 2231 FOR ALTERNATE BLVD CONFIGURATIONS

ALL DIMENSIONS IN METRES UNLESS OTHERWISE NOTED

ID	OBJECT	REFERENCE	SF BLVD	RF BLVD	RF MDNO
(A)	HYDRANT	FOC	1.50	1.50	2.375
(B)	TREE	FOC	1.25	1.25	3.175
(C)	STREETLIGHT + PEDESTALS	FOC	1.25	1.25	2.675
(D)	ALTERNATE UTILITY TRENCH	PL	1.10	1.10	1.10
(E)	TRANSFORMER	FOC	1.285	1.465	3.310
(F)	REFERENCE DRAWING	-	2206A/B	2206A/B	2207A/B

- NOTE:
- UTILITY OFFSETS FROM ROADWAY INFRASTRUCTURE AND BETWEEN UTILITIES TO BE PROVIDED AS PER VOLUME 1.
 - WATER TO BE ON OPPOSITE SIDE OF MAIN POWER.
 - PIPE SIZES AND DEPTH VARIES.
 - LANDSCAPING MUST NOT COVER POLE BASE.
 - DEPTH OF MAIN POWER & TELECOMMUNICATIONS TRENCH TO BE MINIMUM 1.40m.
 - DEPTH OF GAS TRENCH TO BE MINIMUM 1.10m WITHIN ROAD ROW.
 - GAS MAIN LOCATED ON EASEMENTS.
 - PLACE CLAY PLUG IF LANDSCAPING NOT UNDERTAKEN BY ROAD CONTRACTOR.
 - CROWNS ARE MEASURED FROM LIP OF GUTTER.
 - STREETLIGHT CABLE CAN BE INSTALLED AT THE SAME ALIGNMENT AS POWER AND COMMUNICATIONS.
 - MULTI-PARTY UTILITIES TRENCHING EASEMENT REFER TO DETAIL #5700.
 - ADDITIONAL EASEMENT MAY BE REQUIRED FOR EPOR POWER STREET FURNITURE.

STANDARD DRAWING

8.00m URBAN LOCAL RESIDENTIAL (BOULEVARD WALK) - 17.00m ROW

DATE APPROVED: **2025**
SCALE: **N.T.S.**

DRAWN BY: **FR**
CHECKED BY: **JN**

APPROVED:

DRAWING NUMBER: **2230**

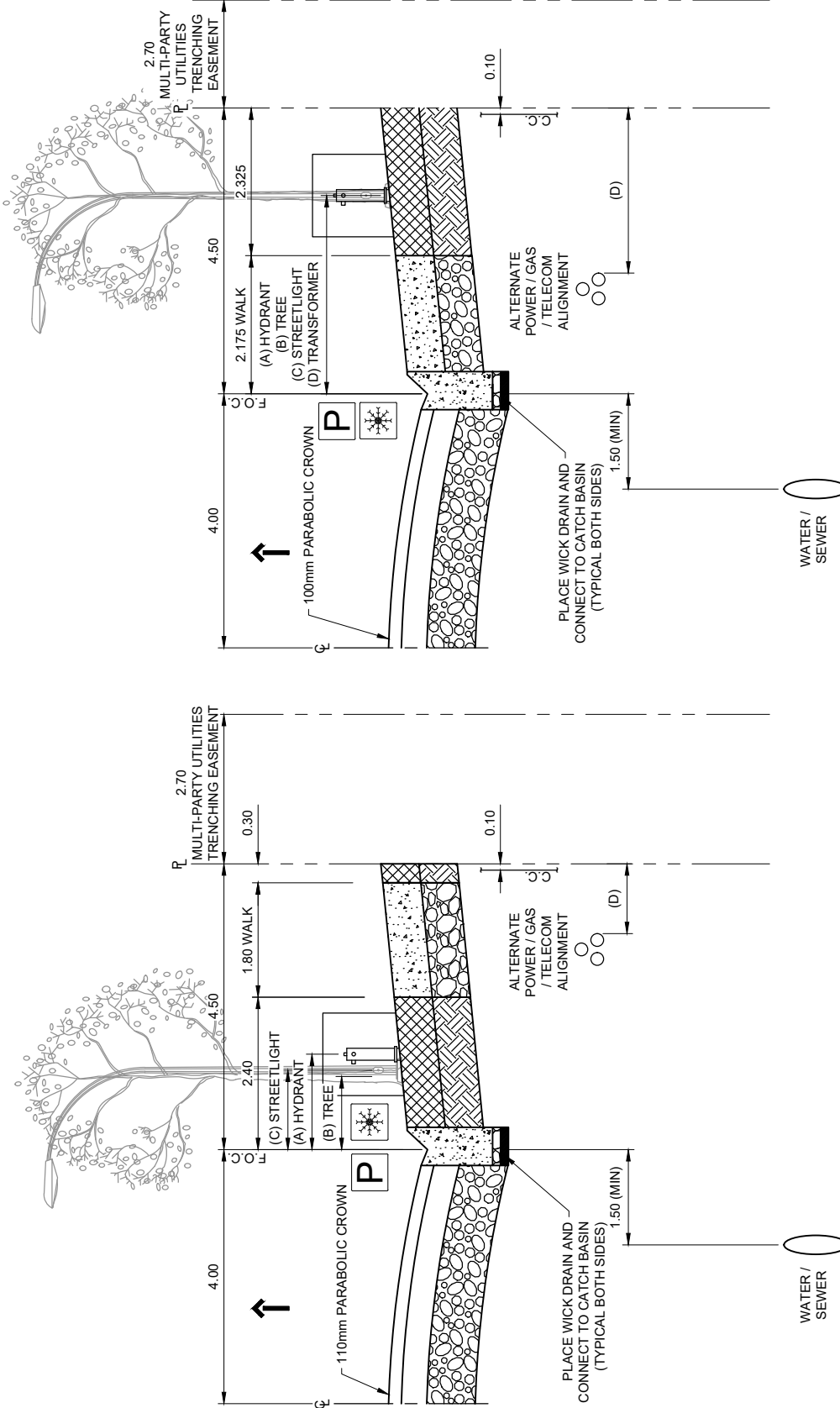

LEGEND:

- SNOW STORAGE AREA
- PARKING
- DRIVING LANE

REFER TO DETAIL 2230 FOR ALTERNATIVE BLVD CONFIGURATIONS

ALL DIMENSIONS IN METRES UNLESS OTHERWISE NOTED

ID	OBJECT	REFERENCE	DISTANCE TO CENTRE OF OBJECT (m)		
			SF BLVD	RF BLVD	RF MONO
(A)	HYDRANT	FOC	1.50	1.50	2.475
(B)	TREE	FOC	1.25	1.25	3.175
(C)	STREETLIGHT + PEDESTALS	FOC	1.25	1.25	2.675
(D)	ALTERNATE UTILITY TRENCH	PL	1.10	1.10	1.10
(E)	TRANSFORMER	FOC	1.285	1.485	3.310
(F)	REFERENCE DRAWING	-	2206A/B	2206A/B	2207A/B



STANDARD DRAWING

8.00m LOCAL RESIDENTIAL (ALTERNATIVE BOULEVARDS) - 17.00m ROW

DATE APPROVED: **2025**

DRAWN BY: **FR**

APPROVED:

DRAWING NUMBER: **2231**

SCALE: **N.T.S.**

CHECKED BY: **JN**

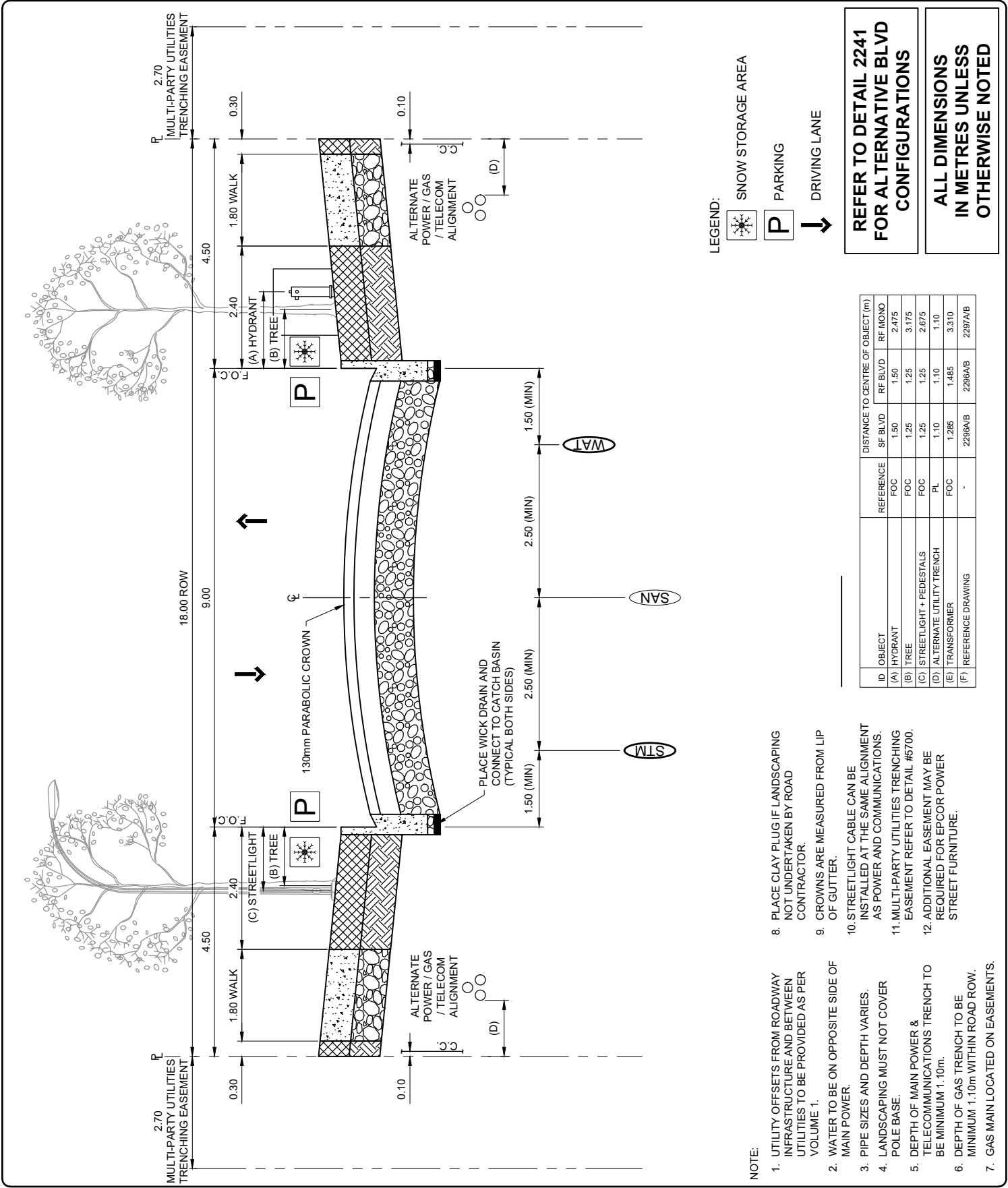

REFER TO DETAIL 2241 FOR ALTERNATIVE BLVD CONFIGURATIONS

ALL DIMENSIONS IN METRES UNLESS OTHERWISE NOTED

LEGEND:

- SNOW STORAGE AREA
- P PARKING
- DRIVING LANE

ID	OBJECT	REFERENCE	DISTANCE TO CENTRE OF OBJECT (m)		
			SF BLVD	RF BLVD	RF MONO
(A)	HYDRANT	FOC	1.50	1.50	2.475
(B)	TREE	FOC	1.25	1.25	3.175
(C)	STREETLIGHT + PEDESTALS	FOC	1.25	1.25	2.675
(D)	ALTERNATE UTILITY TRENCH	PL	1.10	1.10	1.10
(E)	TRANSFORMER	FOC	1.265	1.465	3.310
(F)	REFERENCE DRAWING	-	2206A/B	2206A/B	2207A/B

- NOTE:
- UTILITY OFFSETS FROM ROADWAY INFRASTRUCTURE AND BETWEEN UTILITIES TO BE PROVIDED AS PER VOLUME 1.
 - WATER TO BE ON OPPOSITE SIDE OF MAIN POWER.
 - PIPE SIZES AND DEPTH VARIES.
 - LANDSCAPING MUST NOT COVER POLE BASE.
 - DEPTH OF MAIN POWER & TELECOMMUNICATIONS TRENCH TO BE MINIMUM 1.40m.
 - DEPTH OF GAS TRENCH TO BE MINIMUM 1.10m WITHIN ROAD ROW.
 - GAS MAIN LOCATED ON EASEMENTS.
 - PLACE CLAY PLUG IF LANDSCAPING NOT UNDERTAKEN BY ROAD CONTRACTOR.
 - CROWNS ARE MEASURED FROM LIP OF GUTTER.
 - STREETLIGHT CABLE CAN BE INSTALLED AT THE SAME ALIGNMENT AS POWER AND COMMUNICATIONS.
 - MULTI-PARTY UTILITIES TRENCHING EASEMENT REFER TO DETAIL #6700.
 - ADDITIONAL EASEMENT MAY BE REQUIRED FOR EPOR POWER STREET FURNITURE.

STANDARD DRAWING

9.00m LOCAL RESIDENTIAL (BOULEVARD WALK) - 18.00m ROW

DATE APPROVED: 2025	DRAWN BY: FR	APPROVED: 	DRAWING NUMBER: 2240
SCALE: N.T.S.	CHECKED BY: JN		

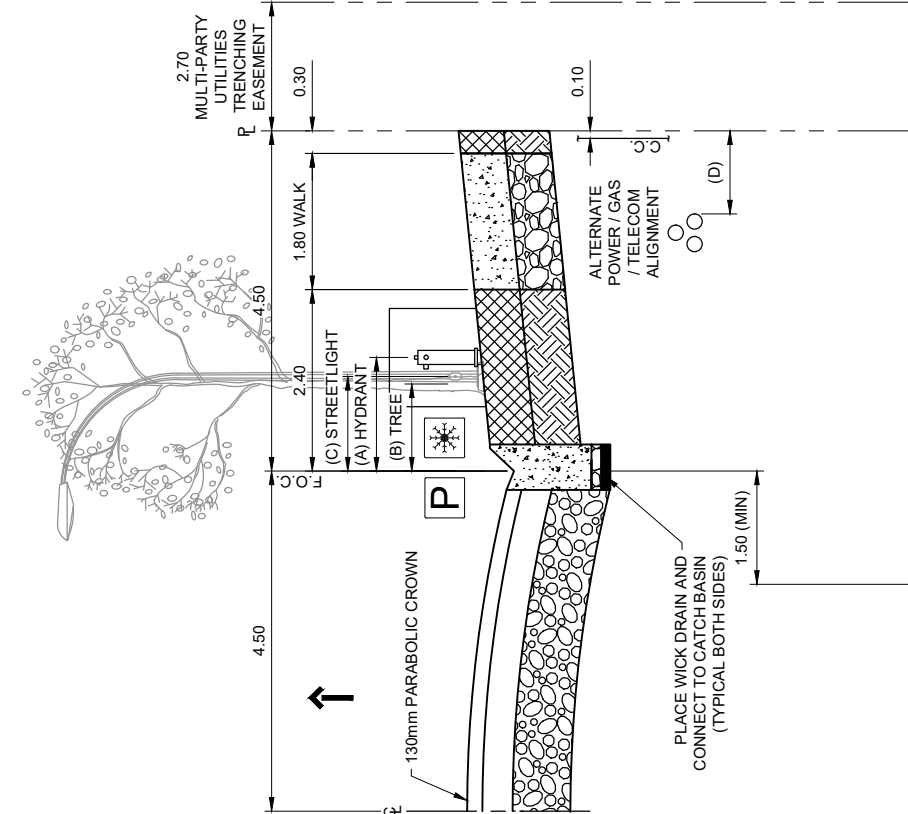
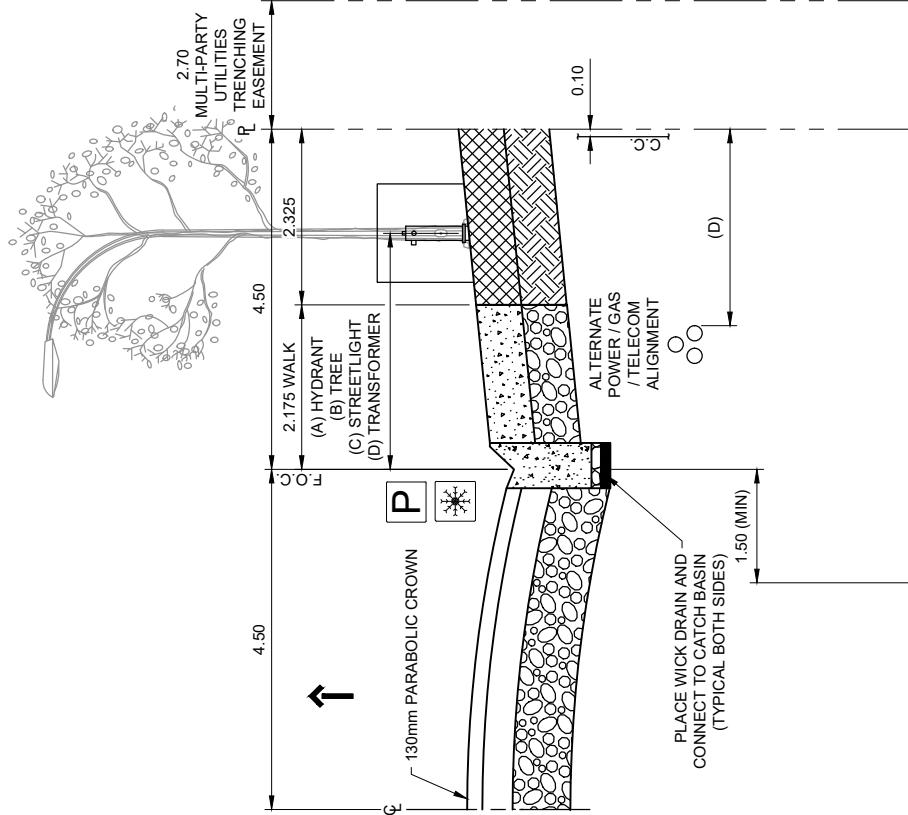

LEGEND:

- SNOW STORAGE AREA
- PARKING
- DRIVING LANE

REFER TO DETAIL 2240 FOR ALTERNATIVE BLVD CONFIGURATIONS

ALL DIMENSIONS IN METRES UNLESS OTHERWISE NOTED

ID	OBJECT	REFERENCE	DISTANCE TO CENTRE OF OBJECT (m)			
			SF BLVD	RF BLVD	RF MONO	RF DIANO
(A)	HYDRANT	FOC	1.50	1.50	2.475	3.175
(B)	TREE	FOC	1.25	1.25	2.675	3.310
(C)	STREETLIGHT + PEDESTALS	FOC	1.25	1.25	2.675	3.310
(D)	ALTERNATE UTILITY TRENCH	PL	1.10	1.10	1.10	1.10
(E)	TRANSFORMER	FOC	1.285	1.485	2.285A/B	2.287A/B
(F)	REFERENCE DRAWING	-	2.286A/B	2.286A/B	2.286A/B	2.287A/B



STANDARD DRAWING

9.00m LOCAL RESIDENTIAL (ALTERNATIVE BOULEVARDS) - 18.00m ROW

DATE APPROVED: **2025**

SCALE: **N.T.S.**

DRAWN BY: **FR**

CHECKED BY: **JN**

APPROVED:

DRAWING NUMBER: **2241**

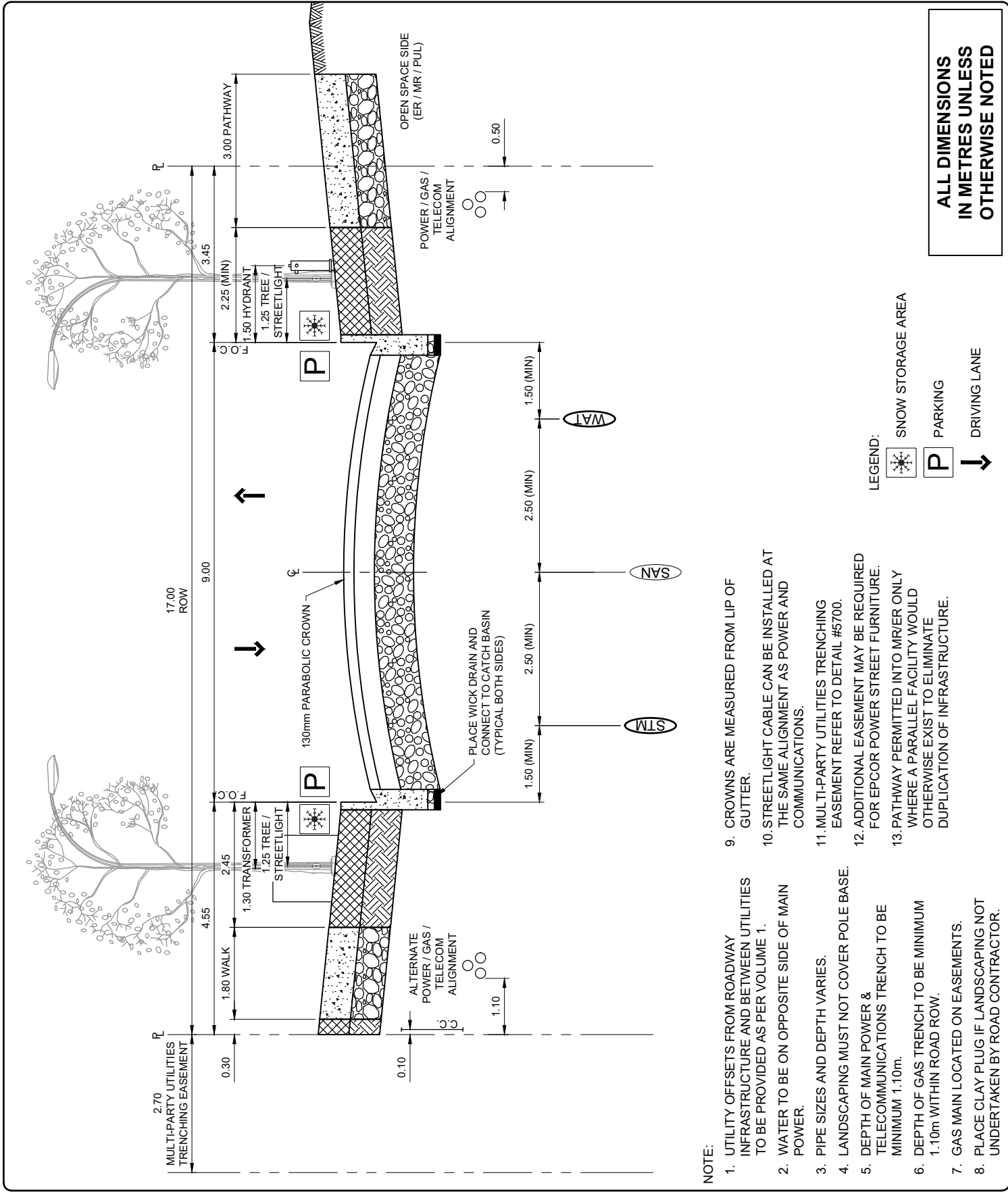

**ALL DIMENSIONS
IN METRES UNLESS
OTHERWISE NOTED**

- LEGEND:
- SNOW STORAGE AREA
 - PARKING
 - DRIVING LANE

- NOTE:
1. UTILITY OFFSETS FROM ROADWAY INFRASTRUCTURE AND BETWEEN UTILITIES TO BE PROVIDED AS PER VOLUME 1.
 2. WATER TO BE ON OPPOSITE SIDE OF MAIN POWER.
 3. PIPE SIZES AND DEPTH VARIES.
 4. LANDSCAPING MUST NOT COVER POLE BASE.
 5. DEPTH OF MAIN POWER & TELECOMMUNICATIONS TRENCH TO BE MINIMUM 1.10m.
 6. DEPTH OF GAS TRENCH TO BE MINIMUM 1.10m WITHIN ROAD ROW.
 7. GAS MAIN LOCATED ON EASEMENTS.
 8. PLACE CLAY PLUG IF LANDSCAPING NOT UNDERTAKEN BY ROAD CONTRACTOR.
 9. CROWNS ARE MEASURED FROM LIP OF GUTTER.
 10. STREETLIGHT CABLE CAN BE INSTALLED AT THE SAME ALIGNMENT AS POWER AND COMMUNICATIONS.
 11. MULTI-PARTY UTILITIES TRENCHING EASEMENT REFER TO DETAIL #5700.
 12. ADDITIONAL EASEMENT MAY BE REQUIRED FOR EPCOR POWER STREET FURNITURE.
 13. PATHWAY PERMITTED INTO MVR/ER ONLY WHERE A PARALLEL FACILITY WOULD OTHERWISE EXIST TO ELIMINATE DUPLICATION OF INFRASTRUCTURE.

STANDARD DRAWING

**9.00m OPEN SPACE LOCAL RESIDENTIAL
(BOULEVARD WALK AND PATHWAY) - 17.00m ROW**

DATE APPROVED: **2025**
SCALE: **N.T.S.**

DRAWN BY: **FR**
CHECKED BY: **JN**

APPROVED:

DRAWING NUMBER: **2250**

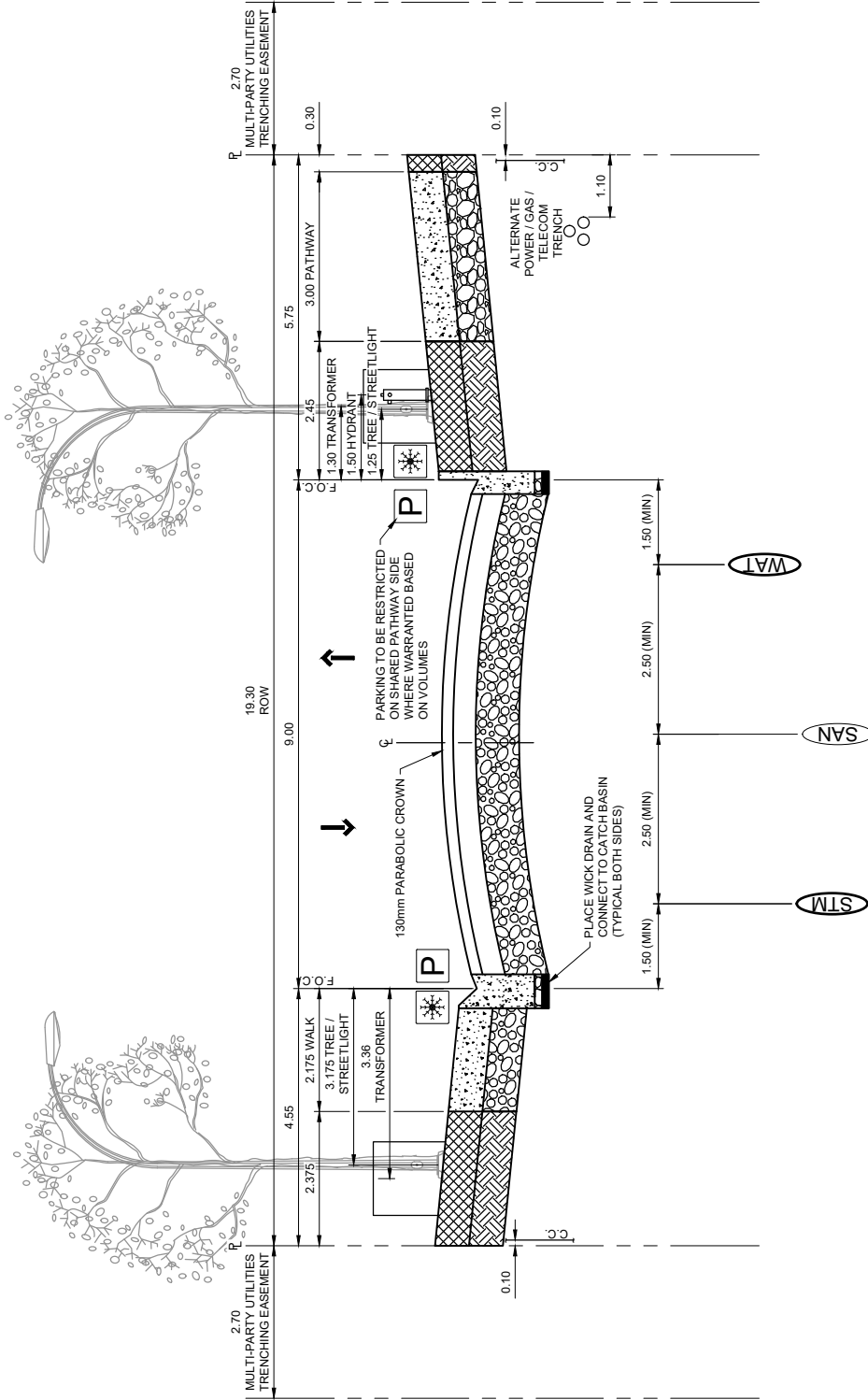

NOTE:

- UTILITY OFFSETS FROM ROADWAY INFRASTRUCTURE AND BETWEEN UTILITIES TO BE PROVIDED AS PER VOLUME 1.
- WATER TO BE ON OPPOSITE SIDE OF MAIN POWER.
- PIPE SIZES AND DEPTH VARIES.
- LANDSCAPING MUST NOT COVER POLE BASE.
- DEPTH OF MAIN POWER & TELECOMMUNICATIONS TRENCH TO BE MINIMUM 1.10m.
- DEPTH OF GAS TRENCH TO BE MINIMUM 1.10m WITHIN ROAD ROW.
- GAS MAIN LOCATED ON EASEMENTS.
- PLACE CLAY PLUG IF LANDSCAPING NOT UNDERTAKEN BY ROAD CONTRACTOR.
- CROWNS ARE MEASURED FROM LIP OF GUTTER.
- STREETLIGHT CABLE CAN BE INSTALLED AT THE SAME ALIGNMENT AS POWER AND COMMUNICATIONS.
- MULTI-PARTY UTILITIES TRENCHING EASEMENT REFER TO DETAIL #5700.
- ADDITIONAL EASEMENT MAY BE REQUIRED FOR EPCOR POWER STREET FURNITURE.

LEGEND:

- SNOW STORAGE AREA
- PARKING
- DRIVING LANE

**ALL DIMENSIONS
IN METRES UNLESS
OTHERWISE NOTED**



STANDARD DRAWING

**9.00 ENHANCED LOCAL WITH PATHWAY
(PARKING ONE OR BOTH SIDES) - 19.30m ROW**

DATE APPROVED: **2025**

DRAWN BY: **FR**

APPROVED:

DRAWING NUMBER: **2255**

SCALE: **N.T.S.**

CHECKED BY: **JN**

**ALL DIMENSIONS
IN METRES UNLESS
OTHERWISE NOTED**

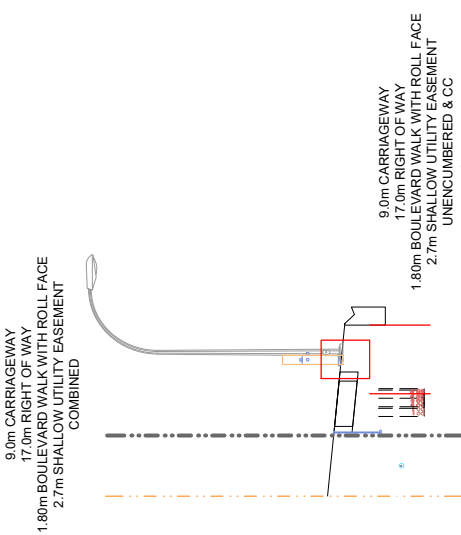
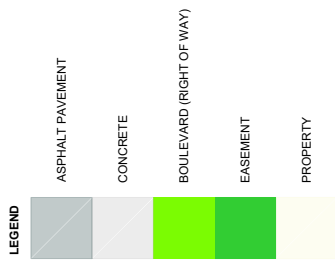
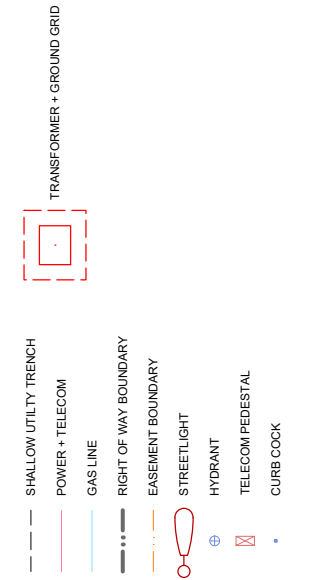

NOTE:
SIDEWALK MEANDERS AROUND TRANSFORMER
SHALLOW UTILITY TRENCH MEANDERS AT TRANSFORMERS AND HYDRANTS / TELECOM / LIGHTS
WATER LINE TO BE INSTALLED AT 1.515m FROM FACE OF CURB IF ON SAME SIDE AS TRANSFORMERS

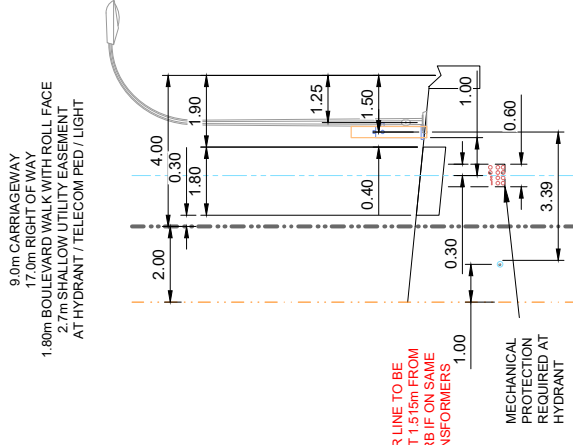

NOTE: WATER LINE TO BE INSTALLED AT 1.515m FROM FACE OF CURB IF ON SAME SIDE AS TRANSFORMERS

MECHANICAL PROTECTION REQUIRED AT HYDRANT

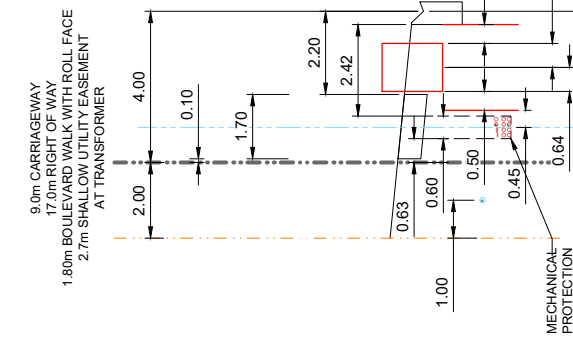

NOTE: SIDEWALK MEANDERS AROUND TRANSFORMER

MECHANICAL PROTECTION REQUIRED AT GROUND GRID

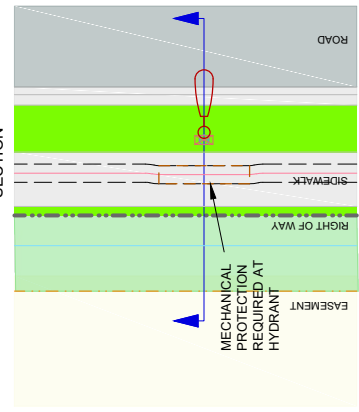

PLAN

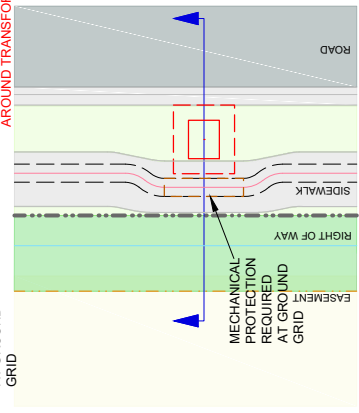

PLAN

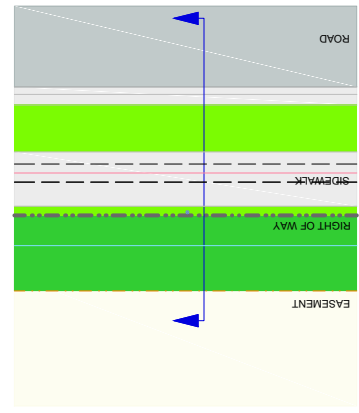

PLAN

**LOCAL ROAD BOULEVARD DETAILS
4.00m BLVD & 1.800m BLVD WALK
2.0m GAS EASEMENT**



STANDARD DRAWING

DATE APPROVED: **2025**

DRAWN BY: **NH**

APPROVED: *[Signature]*

DRAWING NUMBER: **2290A**

SCALE: **N.T.S.**

CHECKED BY: **JN**

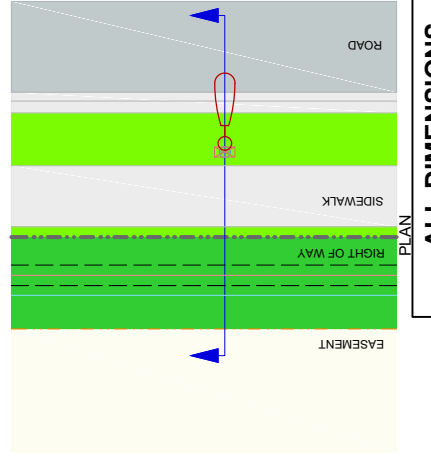
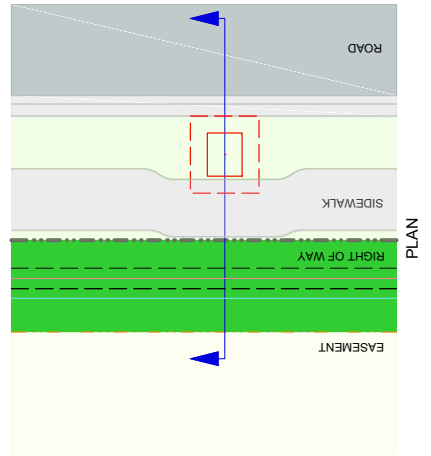
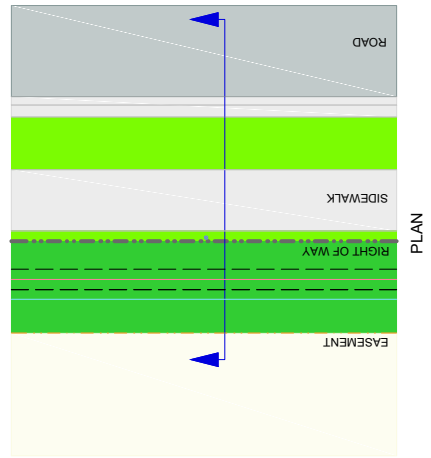
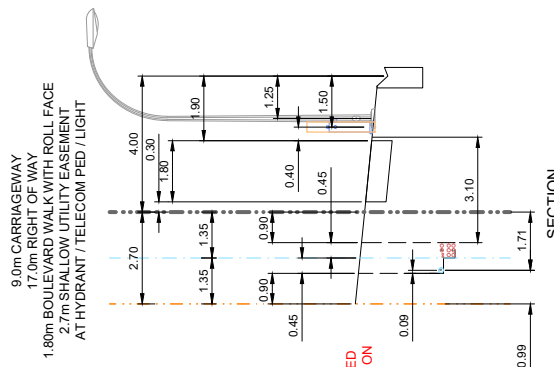
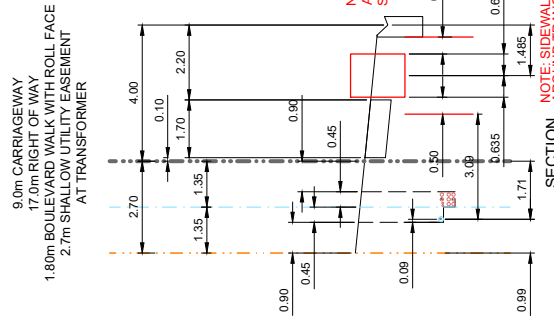
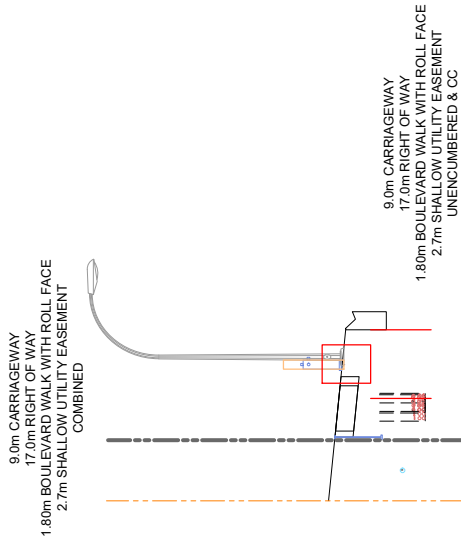
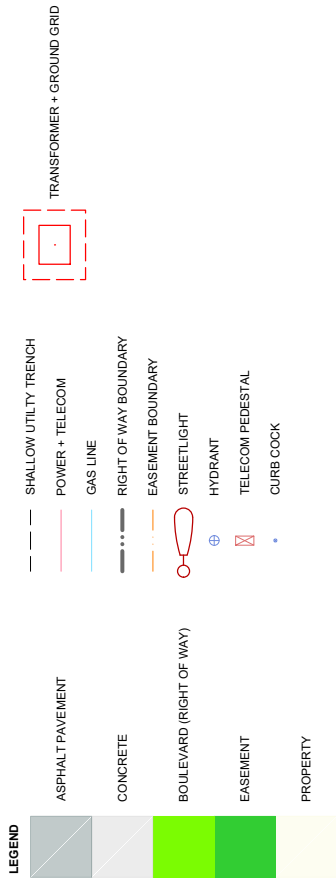

ALL DIMENSIONS
IN METRES UNLESS
OTHERWISE NOTED



STANDARD DRAWING

DATE APPROVED: **2025**

SCALE: **N.T.S.**

DRAWN BY: **NH**

CHECKED BY: **JN**

APPROVED: *[Signature]*

DRAWING NUMBER: **2290B**

**ALL DIMENSIONS
IN METRES UNLESS
OTHERWISE NOTED**

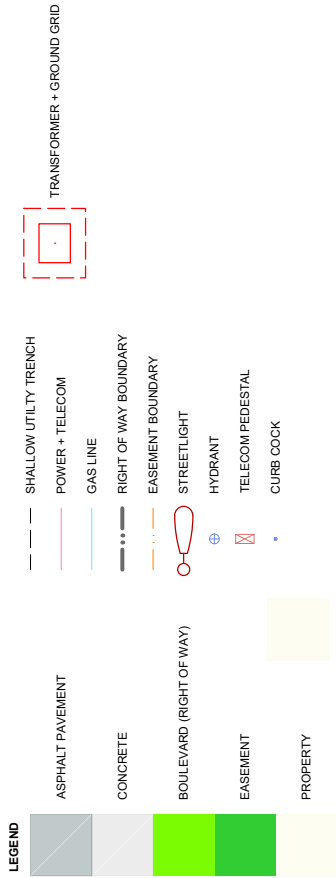

9.0m CARRIAGEWAY
17.0m RIGHT OF WAY
2.100m ROLL FACE MONOWALK
2.0 GAS EASEMENT
COMBINED

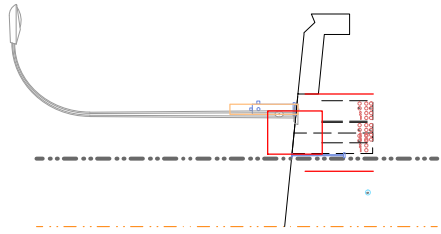

NOTE:
TRANSFORMER GROUND GRID
EXTENDS INTO GAS EASEMENT.
GAS MEANDERS AROUND
TRANSFORMER GRID.
SHALLOW UTILITY TRENCH
MEANDERS AT TRANSFORMERS
AND HYDRANTS / TELECOM /
LIGHTS.

9.0m CARRIAGEWAY
17.0m RIGHT OF WAY
2.100m ROLL FACE MONOWALK
2.0 GAS EASEMENT
AT HYDRANT / TELECOM PED / LIGHT

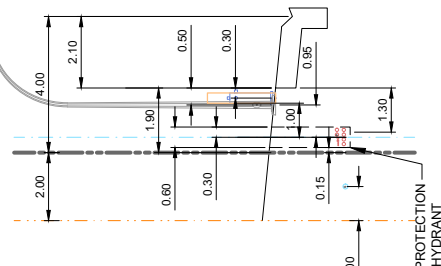

9.0m CARRIAGEWAY
17.0m RIGHT OF WAY
2.100m ROLL FACE MONOWALK
2.0 GAS EASEMENT
AT TRANSFORMER

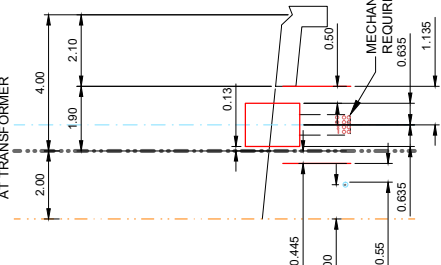

**NOTE: TRANSFORMER
CASE EXTENDS INTO
EASEMENT**

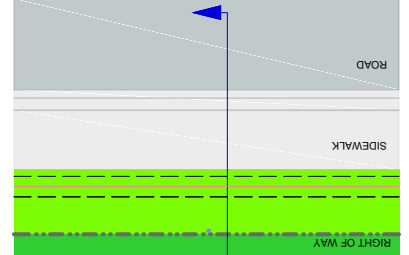
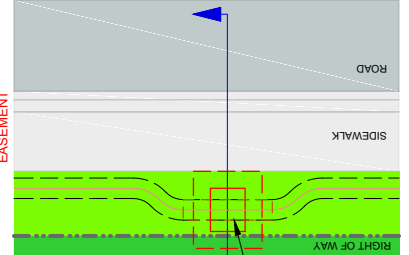
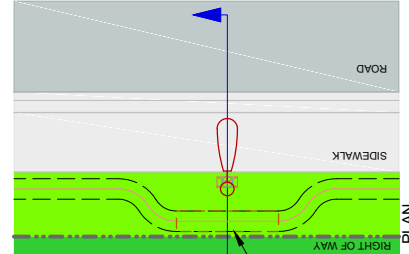

**LOCAL ROAD BOULEVARD DETAILS
4.00m BLVD & 2.100m MONO WALK
2.0m GAS EASEMENT**



STANDARD DRAWING

DATE APPROVED: **2025**

SCALE: **N.T.S.**

DRAWN BY: **NH**

CHECKED BY: **JN**

APPROVED:

DRAWING NUMBER: **2291A**

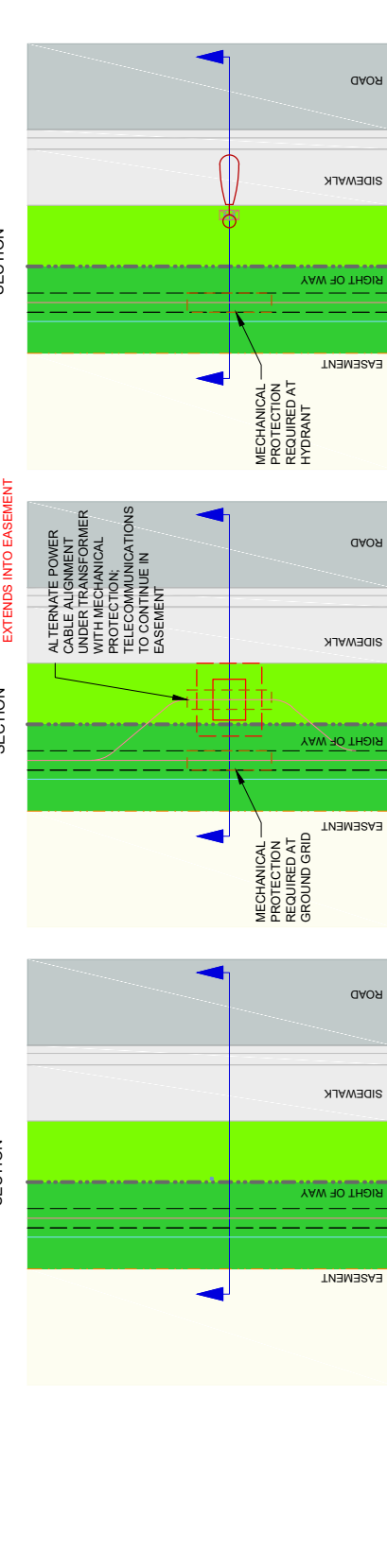
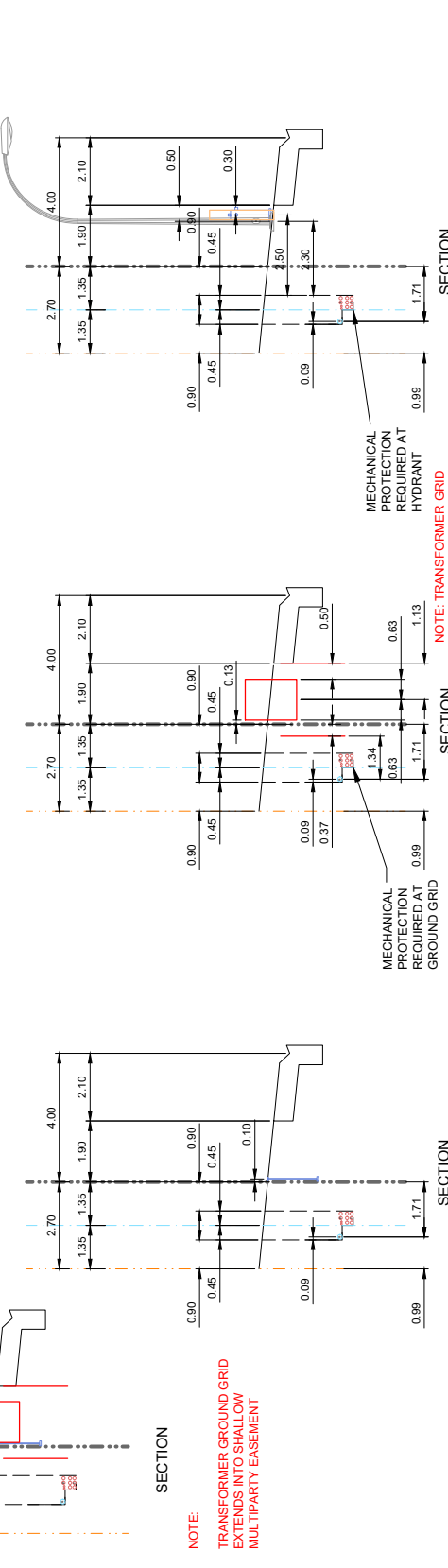
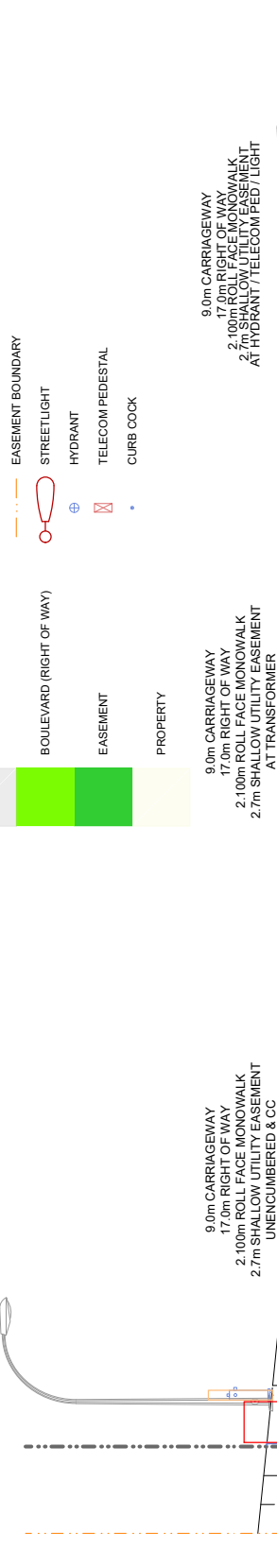

ALL DIMENSIONS IN METRES UNLESS OTHERWISE NOTED

**LOCAL ROAD BOULEVARD DETAILS
4.00m BLVD & 2.100m MONO WALK
2.7m MULTI PARTY EASEMENT**



STANDARD DRAWING

DATE APPROVED: **2025**

DRAWN BY: **NH**

APPROVED: *[Signature]*

DRAWING NUMBER: **2291B**

SCALE: **N.T.S.**

CHECKED BY: **JN**

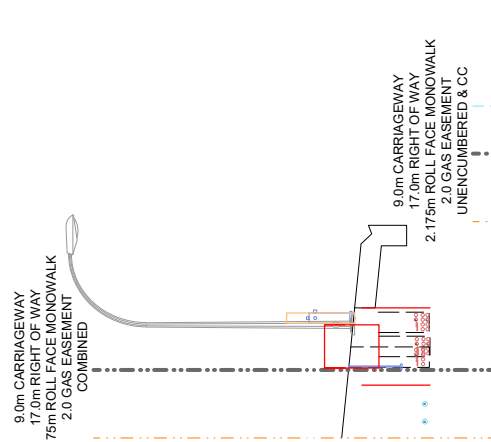
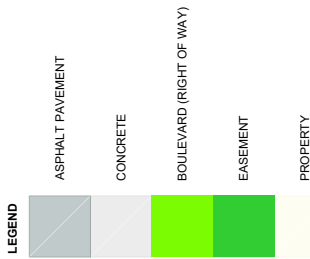
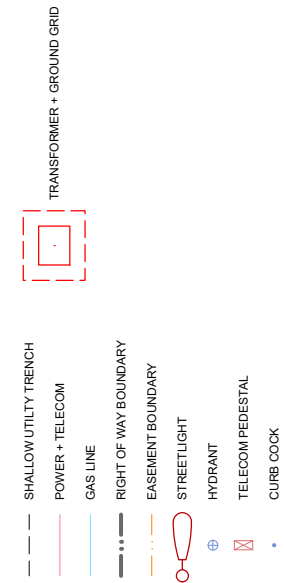

NOTE:
 TRANSFORMER GROUND GRID EXTENDS INTO GAS EASEMENT
 GAS MEANDERS AROUND TRANSFORMER GRID
 SHALLOW UTILITY TRENCH MEANDERS AT TRANSFORMERS AND HYDRANTS / TELECOM / LIGHTS

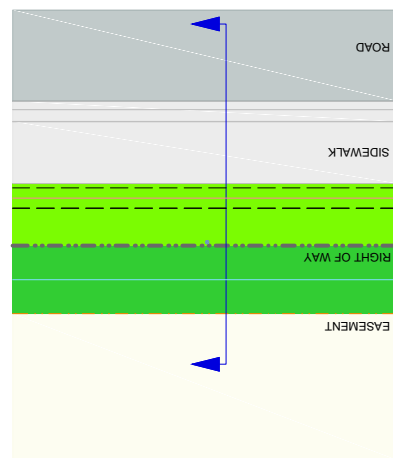
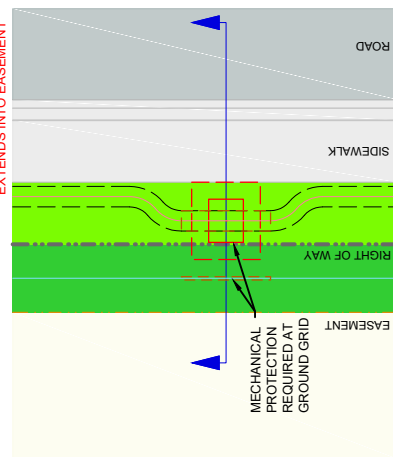
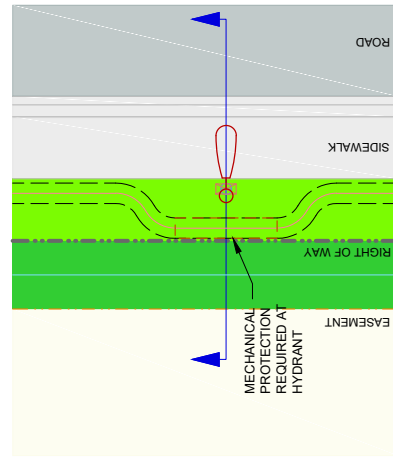
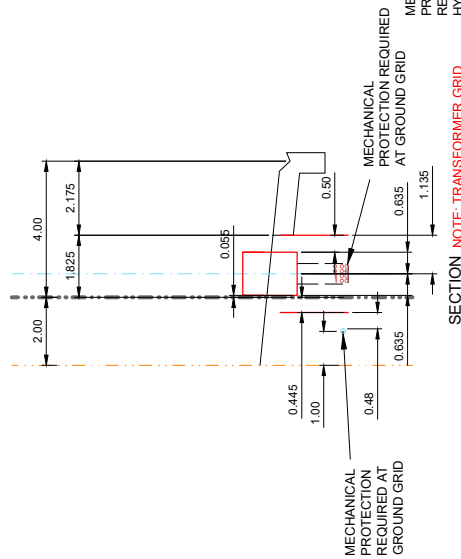
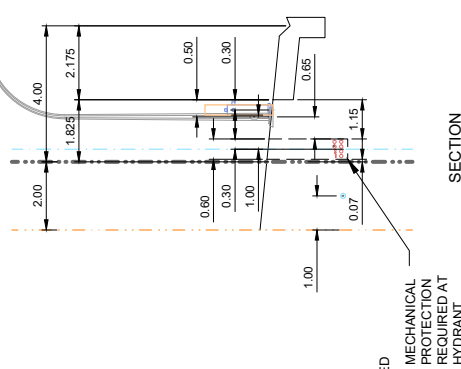

PLAN

PLAN

PLAN

ALL DIMENSIONS
 IN METRES UNLESS
 OTHERWISE NOTED



STANDARD DRAWING

LOCAL ROAD BOULEVARD DETAILS
 4.00m BLVD & 2.175m MONO WALK
 2.0m GAS EASEMENT

DATE APPROVED: 2025

DRAWN BY: NH

APPROVED:

DRAWING NUMBER: 2292A

SCALE: N.T.S.

CHECKED BY: JN

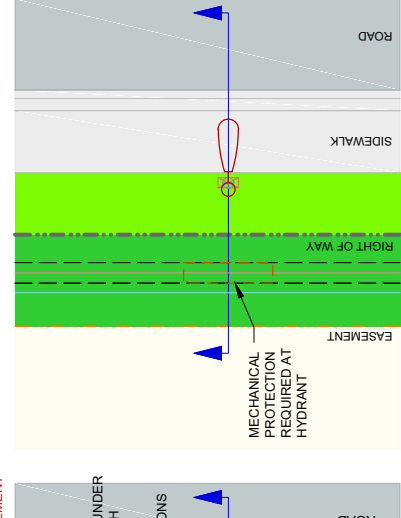
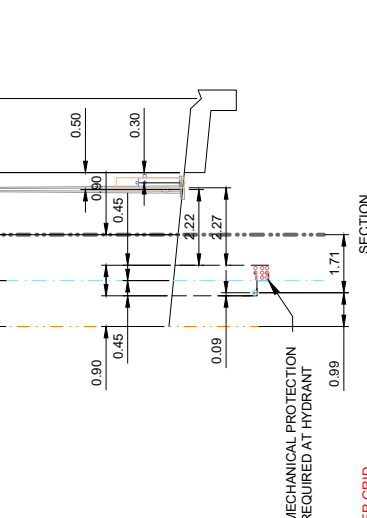
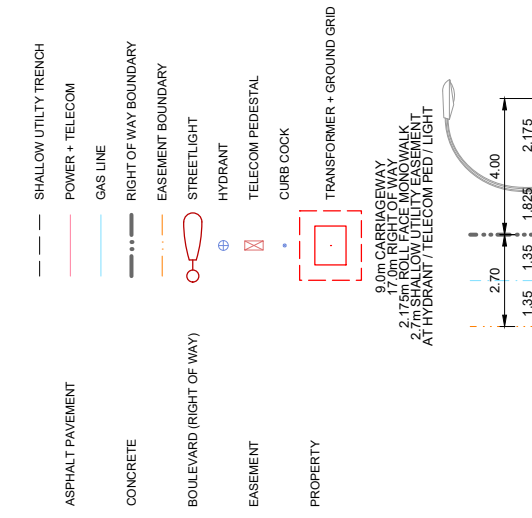
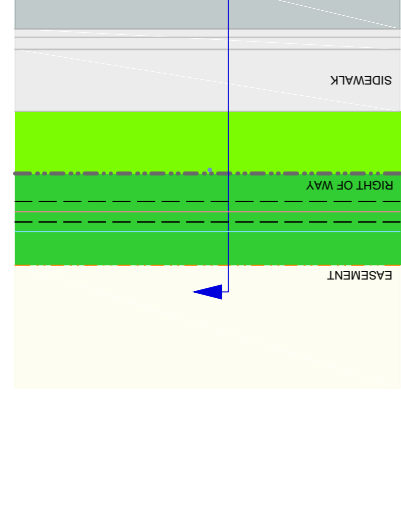
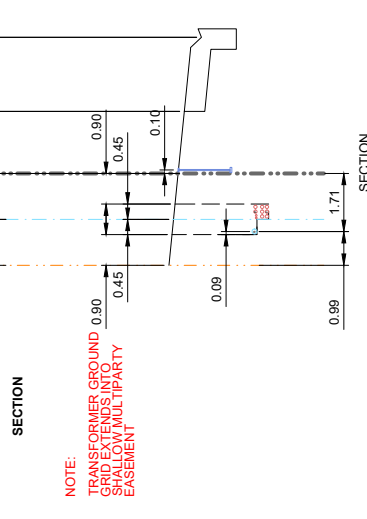
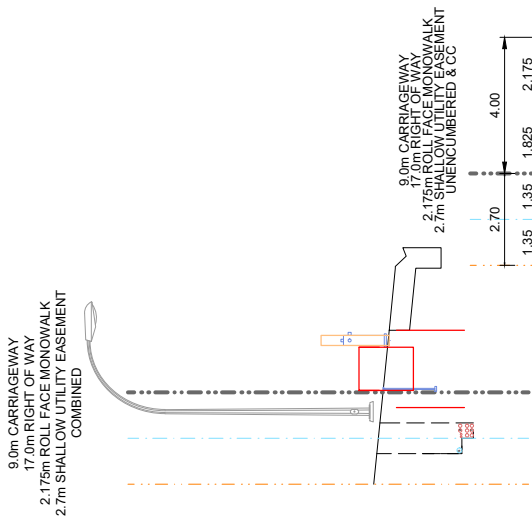

ALL DIMENSIONS
IN METRES UNLESS
OTHERWISE NOTED

LOCAL ROAD BOULEVARD DETAILS
4.00m BLVD & 2.175m MONO WALK
2.7m MULTI PARTY EASEMENT



STANDARD DRAWING

DATE APPROVED: 2025

DRAWN BY: NH

APPROVED: [Signature]

DRAWING NUMBER: 2292B

SCALE: N.T.S.

CHECKED BY: JN

**ALL DIMENSIONS
IN METRES UNLESS
OTHERWISE NOTED**

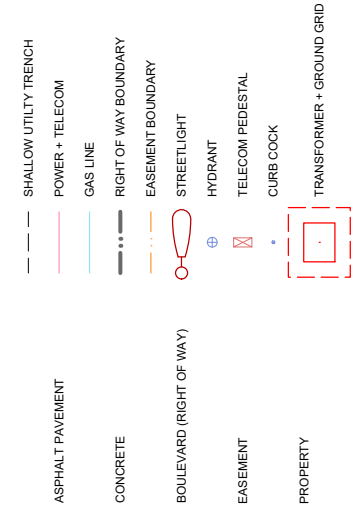

NOTE:
SIDEWALK MEANDERS AROUND TRANSFORMER
SHALLOW UTILITY TRENCH MEANDERS AROUND TRANSFORMER, CC, STREETLIGHT / HYDRANT / TELECOM PED
WATER LINE TO BE INSTALLED AT 1.515m FROM FACE OF CURB IF ON SAME SIDE AS TRANSFORMERS

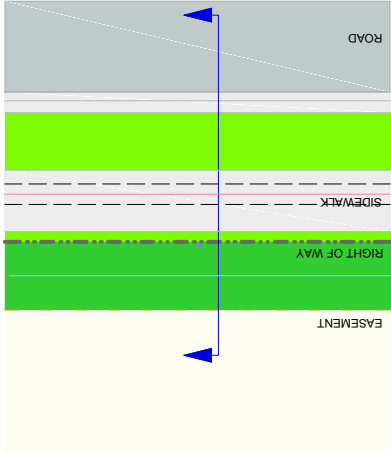
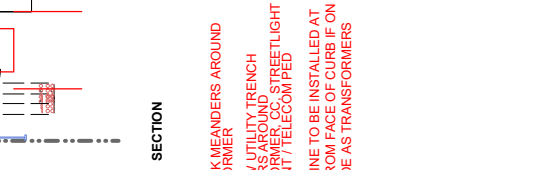
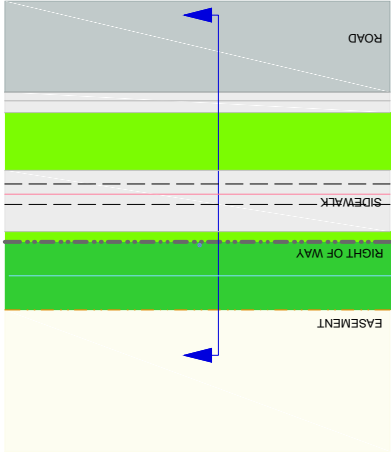
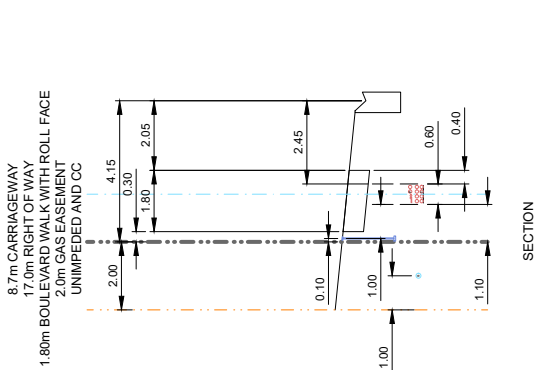
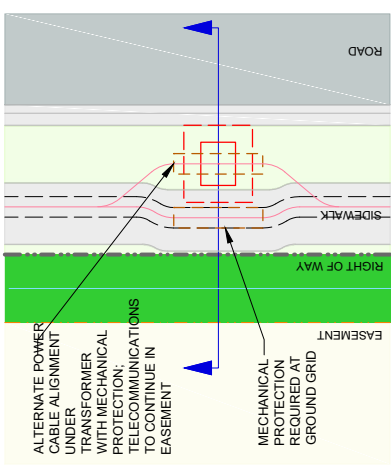
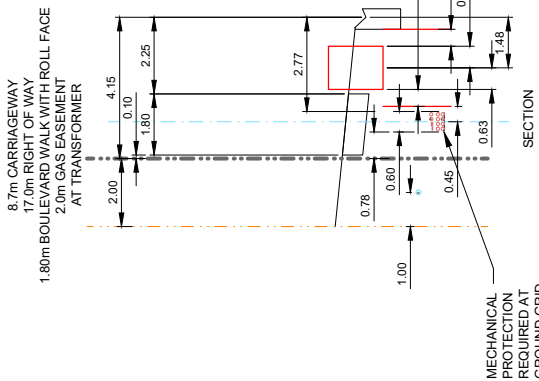

**LOCAL ROAD BOULEVARD DETAILS
4.15m BLVD & 1.800m BLVD WALK
2.0m GAS EASEMENT**



DATE APPROVED: **2025**
SCALE: **N.T.S.**

DRAWN BY: **NH**
CHECKED BY: **JN**

APPROVED: *[Signature]*

DRAWING NUMBER: **2293A**

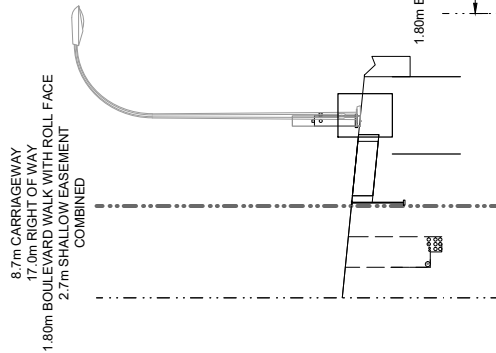
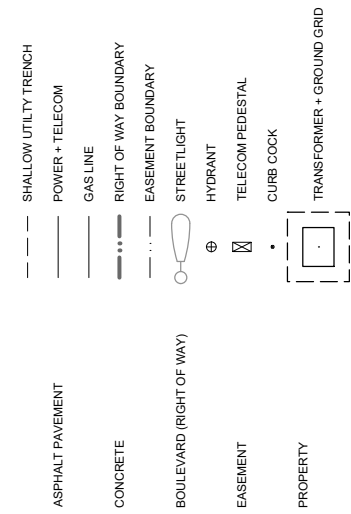

SECTION

NOTE:

SIDEWALK MEANDERS AROUND TRANSFORMER

WATER LINE TO BE INSTALLED AT 1.515m FROM FACE OF CURB IF ON SAME SIDE AS TRANSFORMERS

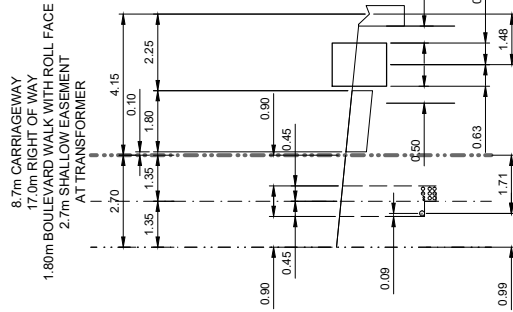

SECTION

NOTE: WATER LINE TO BE INSTALLED AT 1.515m FROM FACE OF CURB IF ON SAME SIDE AS TRANSFORMERS

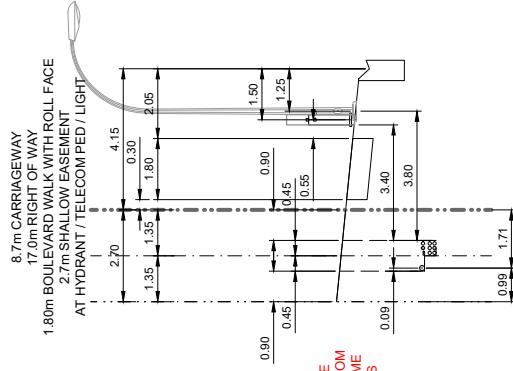

SECTION

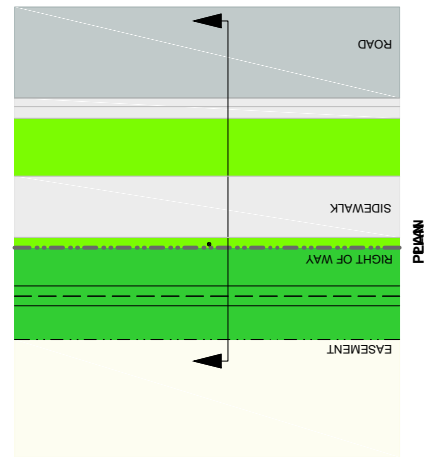

PLAN

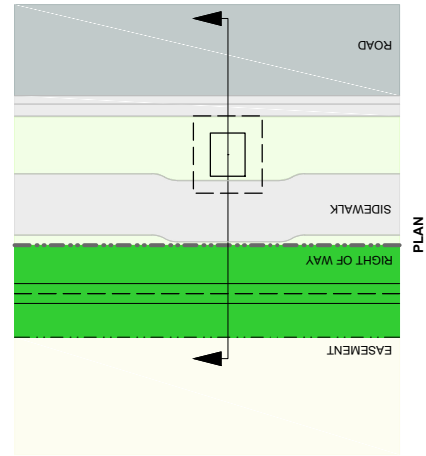

PLAN

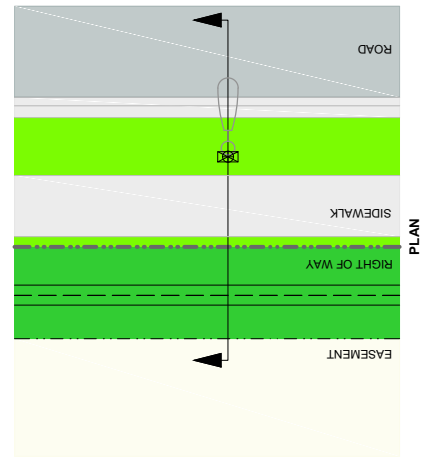

PLAN

ALL DIMENSIONS IN METRES UNLESS OTHERWISE NOTED



STANDARD DRAWING

**LOCAL ROAD BOULEVARD DETAILS
4.15m BLVD & 1.800m BLVD WALK
2.7m MULTI PARTY EASEMENT**

DATE APPROVED: **2025**

DRAWN BY: **NH**

APPROVED:

DRAWING NUMBER: **2293B**

SCALE: **N.T.S.**

CHECKED BY: **JN**

**ALL DIMENSIONS
IN METRES UNLESS
OTHERWISE NOTED**

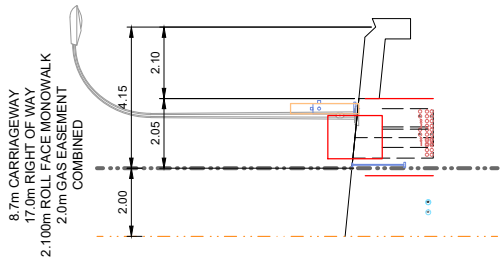

NOTE:
 TRANSFORMER GROUND GRID
 EXTENDS INTO GAS EASEMENT.
 GAS MEANDERS AROUND
 TRANSFORMER GRID.
 SHALLOW UTILITY TRENCH
 MEANDERS AT TRANSFORMERS
 AND HYDRANTS / TELECOM/
 LIGHTS.

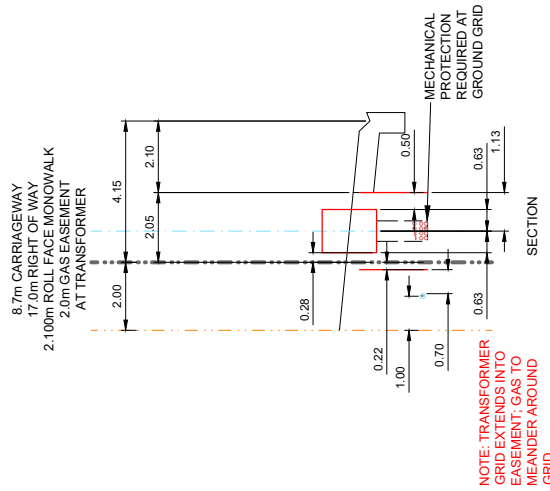

**NOTE: TRANSFORMER
GRID EXTENDS INTO
EASEMENT; GAS TO
MEANDER AROUND
GRID**

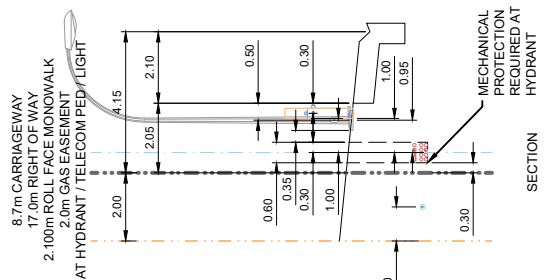

**MECHANICAL
PROTECTION
REQUIRED AT
HYDRANT**

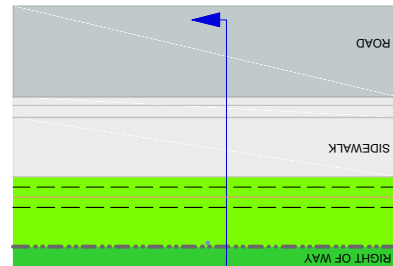
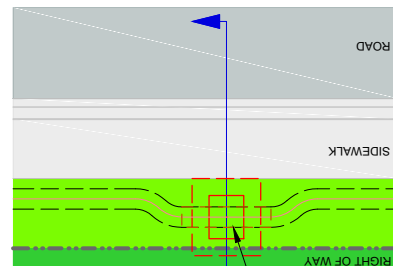
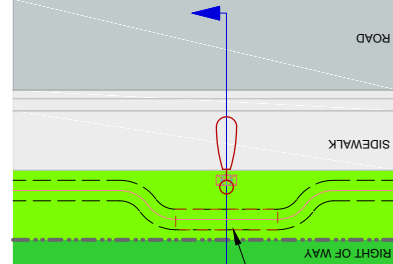

**LOCAL ROAD BOULEVARD DETAILS
4.15m BLVD & 2.100m MONO WALK
2.0m GAS EASEMENT**



DATE APPROVED: **2025**
 SCALE: **N.T.S.**

DRAWN BY: **NH**
 CHECKED BY: **JN**

APPROVED: *[Signature]*

DRAWING NUMBER: **2294A**

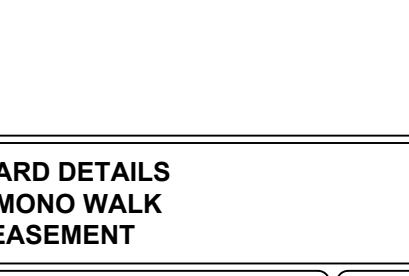
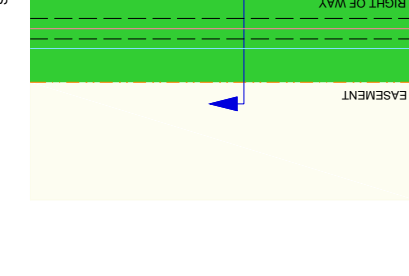
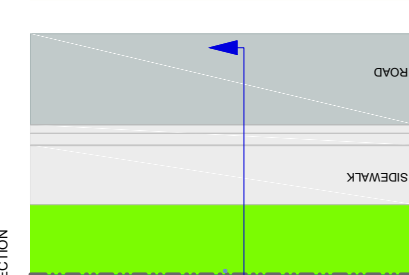
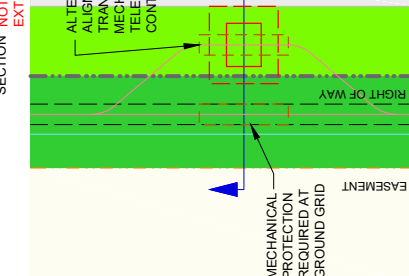
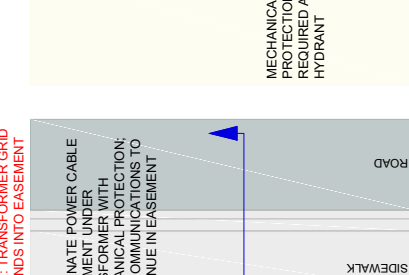
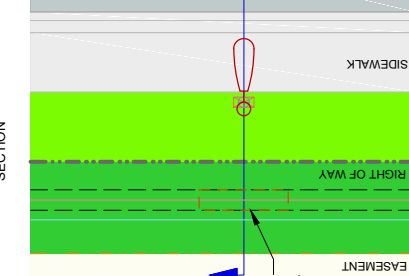
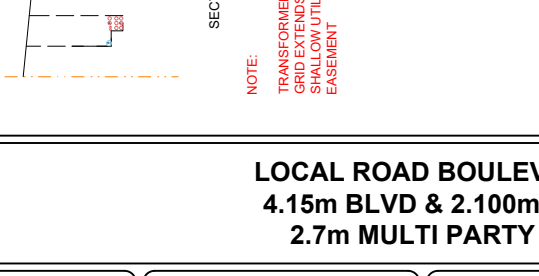
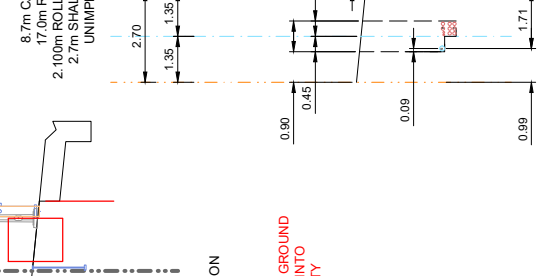
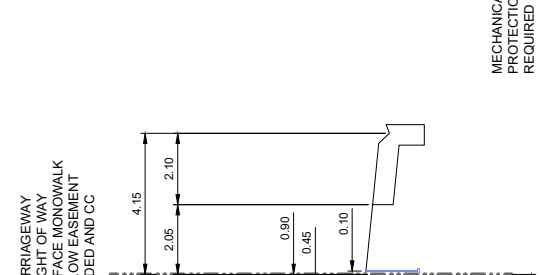
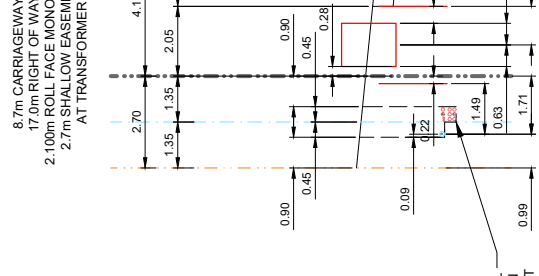
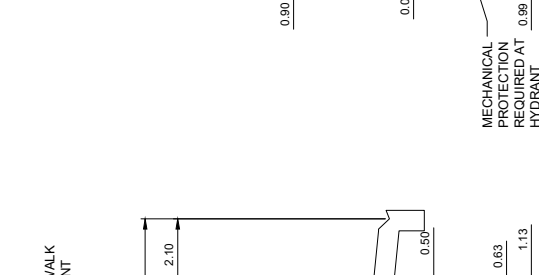
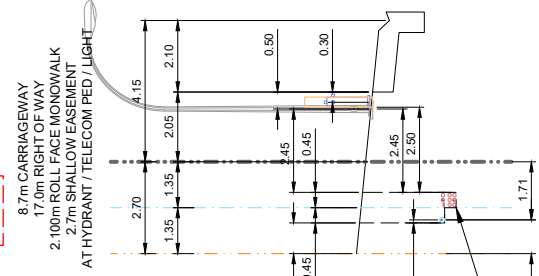
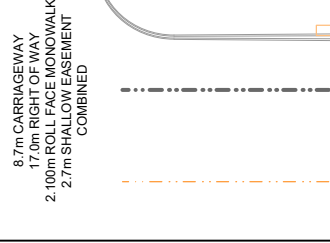
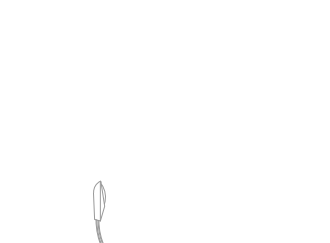
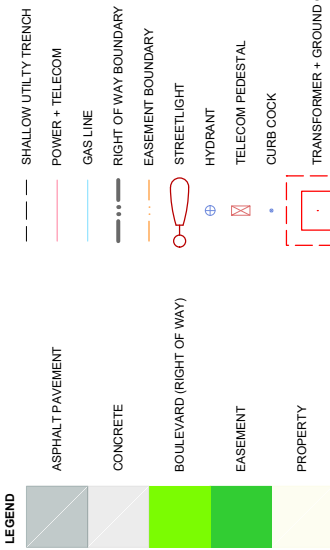

ALL DIMENSIONS IN METRES UNLESS OTHERWISE NOTED

ALL DIMENSIONS IN METRES UNLESS OTHERWISE NOTED

ALL DIMENSIONS IN METRES UNLESS OTHERWISE NOTED

ALL DIMENSIONS IN METRES UNLESS OTHERWISE NOTED

ALL DIMENSIONS IN METRES UNLESS OTHERWISE NOTED

ALL DIMENSIONS IN METRES UNLESS OTHERWISE NOTED

NOTE: TRANSFORMER GROUND GRID EXTENDS INTO SHALLOW UTILITY EASEMENT

NOTE: TRANSFORMER GRID EXTENDS INTO EASEMENT

LOCAL ROAD BOULEVARD DETAILS
4.15m BLVD & 2.100m MONO WALK
2.7m MULTI PARTY EASEMENT



DATE APPROVED: 2025
SCALE: N.T.S.

DRAWN BY: NH
CHECKED BY: JN

APPROVED: [Signature]

DRAWING NUMBER: 2294B

LEGEND

	ASPHALT PAVEMENT		SHALLOW UTILITY TRENCH
	CONCRETE		POWER + TELECOM
	BOULEVARD (RIGHT OF WAY)		GAS LINE
	EASEMENT		RIGHT OF WAY BOUNDARY
	PROPERTY		EASEMENT BOUNDARY
			STREETLIGHT
			HYDRANT
			TELECOM PEDESTAL
			CURB COCK
			TRANSFORMER + GROUND GRID

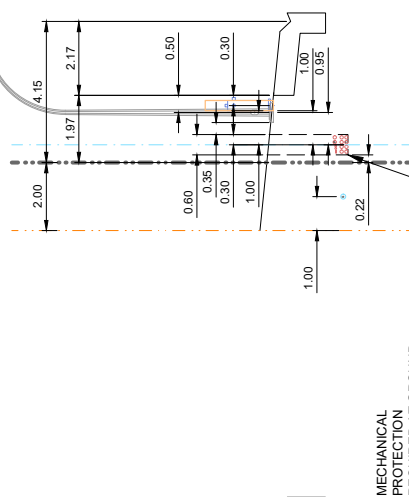
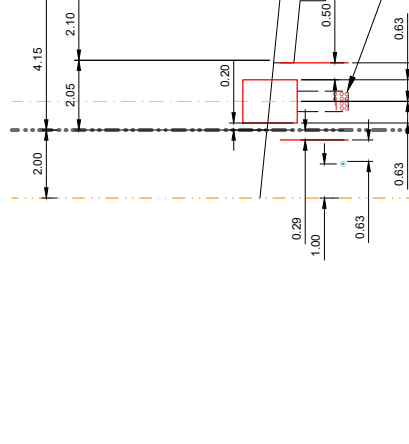
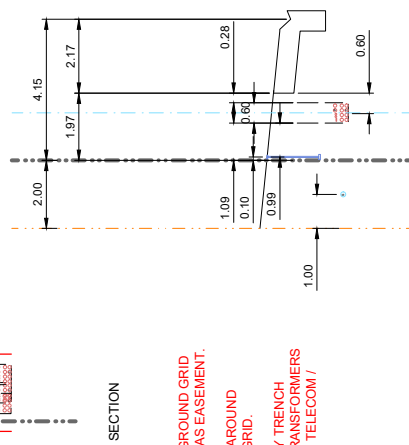
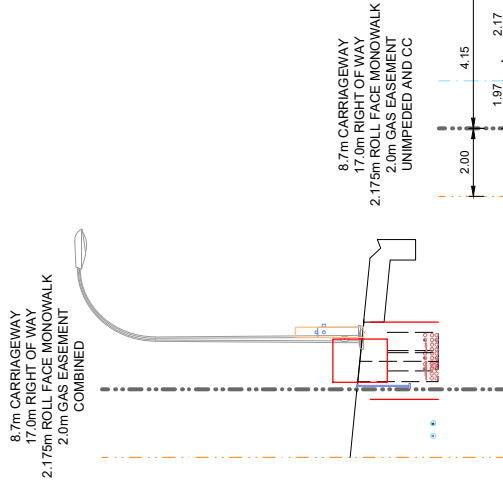

NOTE:
 TRANSFORMER GROUND GRID EXTENDS INTO GAS EASEMENT.
 GAS MEANDERS AROUND TRANSFORMER GRID.
 SHALLOW UTILITY TRENCH MEANDERS AT TRANSFORMERS AND HYDRANTS / TELECOM / LIGHTS.

NOTE: TRANSFORMER GRID EXTENDS INTO EASEMENT

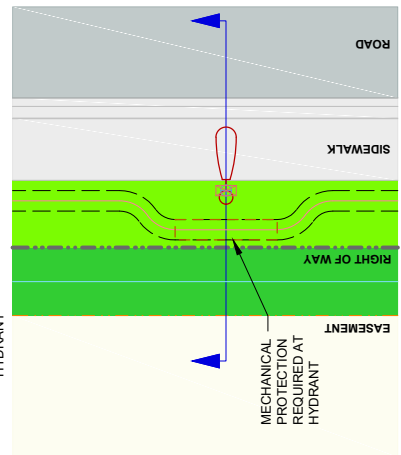
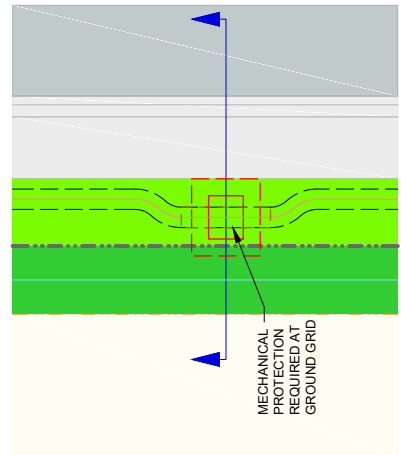
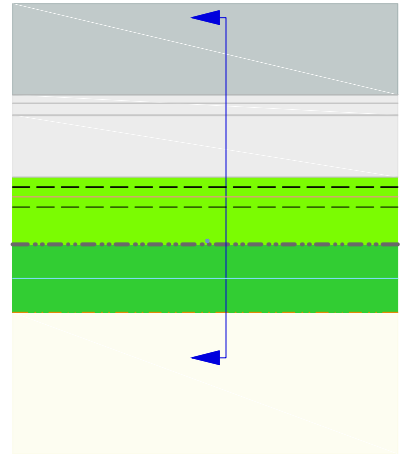

PLAN

PLAN

PLAN

PLAN

PLAN

ALL DIMENSIONS IN METRES UNLESS OTHERWISE NOTED

**LOCAL ROAD BOULEVARD DETAILS
 4.15m BLVD & 2.175m MONO WALK
 2.0m GAS EASEMENT**



STANDARD DRAWING

DATE APPROVED: **2025**

DRAWN BY: **NH**

APPROVED:

DRAWING NUMBER: **2295A**

SCALE: **N.T.S.**

CHECKED BY: **JN**

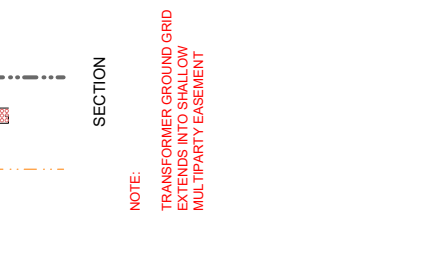
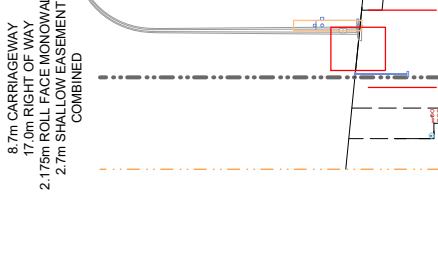
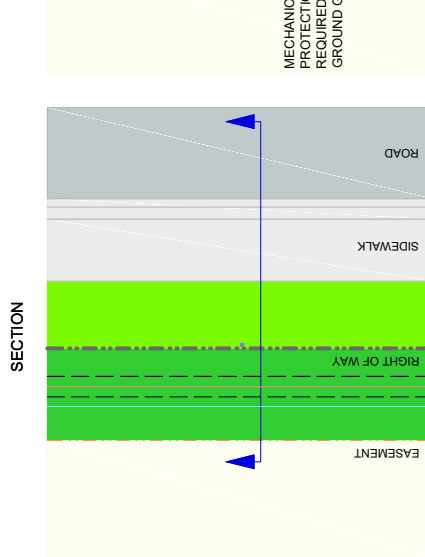
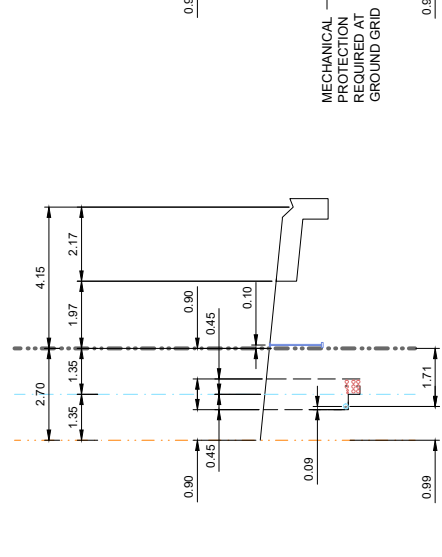
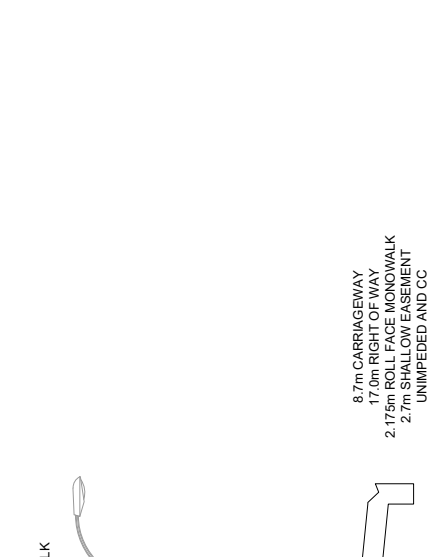
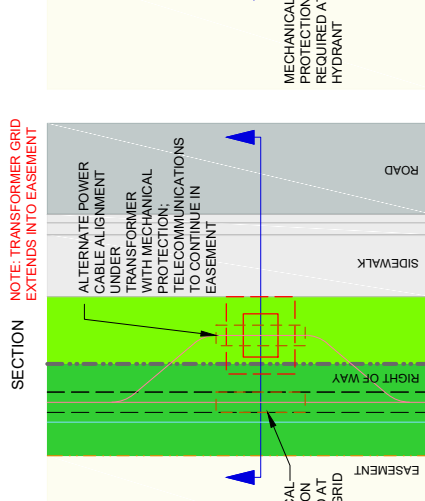
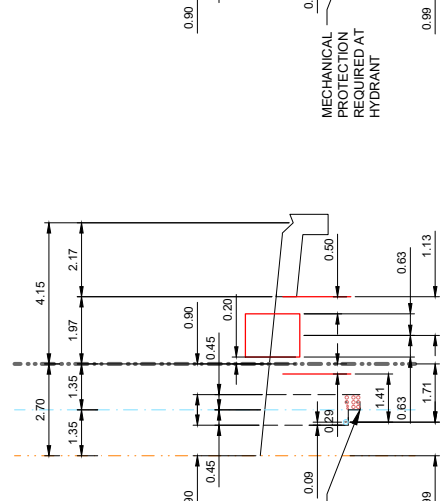
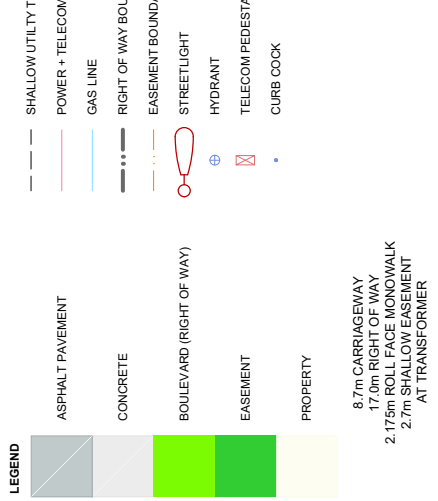
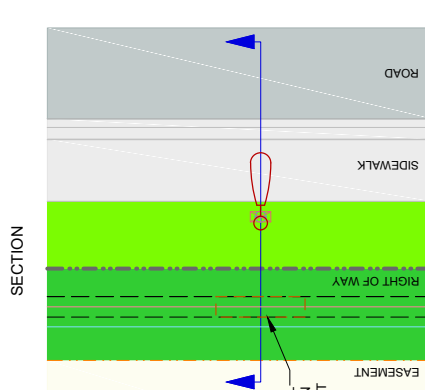
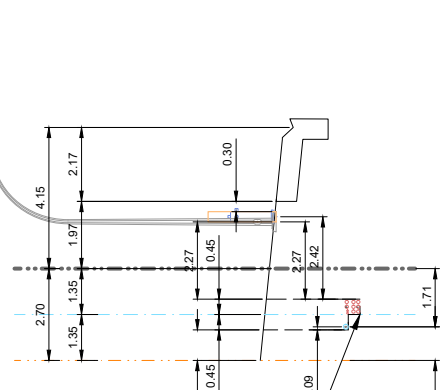
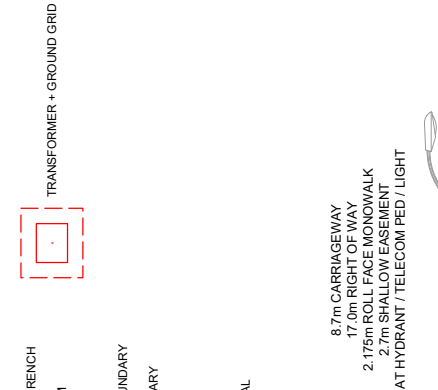
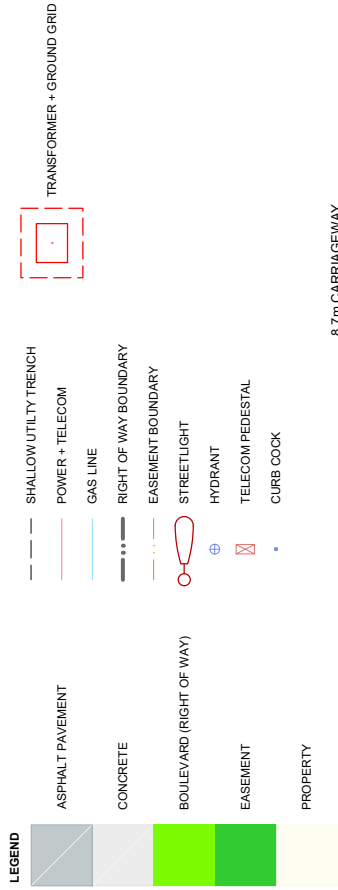

NOTE: TRANSFORMER GROUND GRID EXTENDS INTO SHALLOW MULTIPARTY EASEMENT

NOTE: TRANSFORMER GRID EXTENDS INTO EASEMENT

ALL DIMENSIONS IN METRES UNLESS OTHERWISE NOTED



**LOCAL ROAD BOULEVARD DETAILS
4.15m BLVD & 2.175m MONO WALK
2.7m MULTI PARTY EASEMENT**

DATE APPROVED: **2025**
SCALE: **N.T.S.**

DRAWN BY: **NH**
CHECKED BY: **JN**

APPROVED: *[Signature]*

DRAWING NUMBER: **2295B**

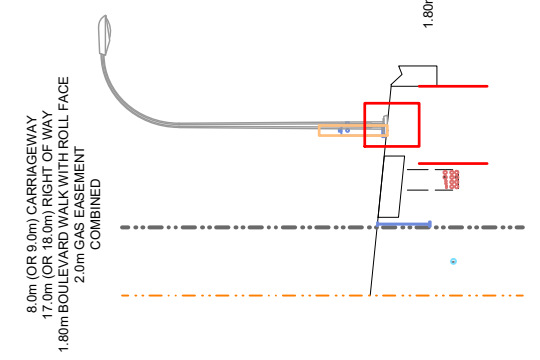
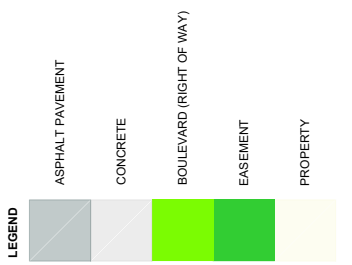
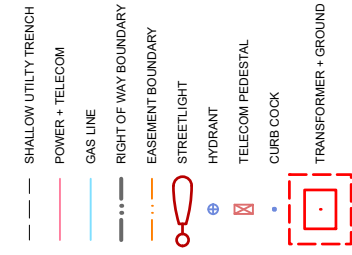

NOTE: WATER LINE TO BE INSTALLED AT 1.515m FROM FACE OF CURB IF ON SAME SIDE AS TRANSFORMERS

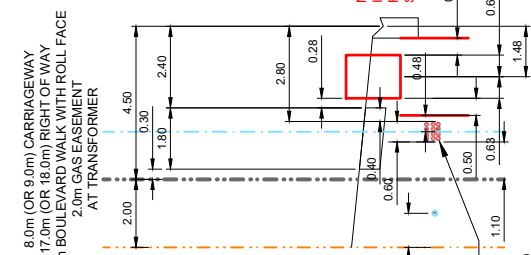
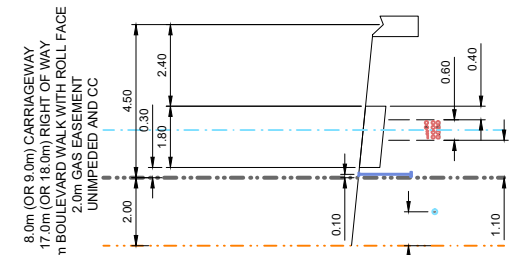

NOTE: WATER LINE TO BE INSTALLED AT 1.515m FROM FACE OF CURB IF ON SAME SIDE AS TRANSFORMERS

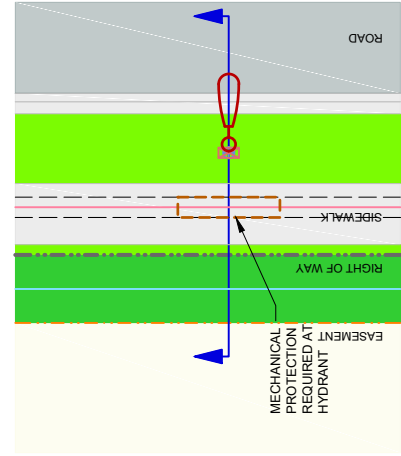
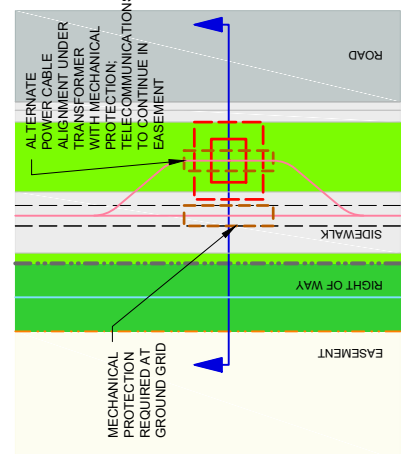
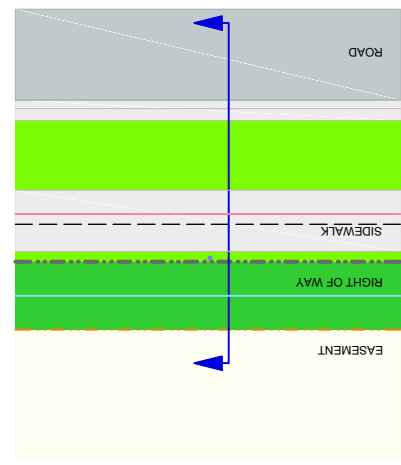
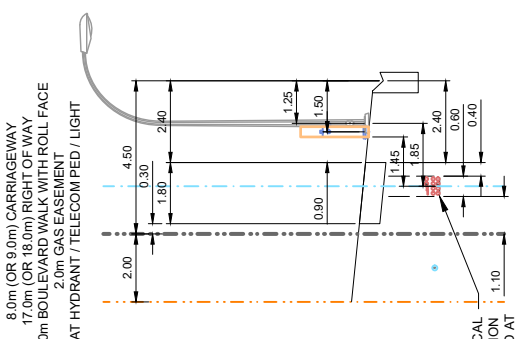

ALL DIMENSIONS IN METRES UNLESS OTHERWISE NOTED

LOCAL ROAD BOULEVARD DETAILS
4.50m BLVD & 1.800m BLVD WALK
2.0m GAS EASEMENT



DATE APPROVED: 2025
SCALE: N.T.S.

DRAWN BY: NH
CHECKED BY: JN

APPROVED: [Signature]

DRAWING NUMBER: 2296A

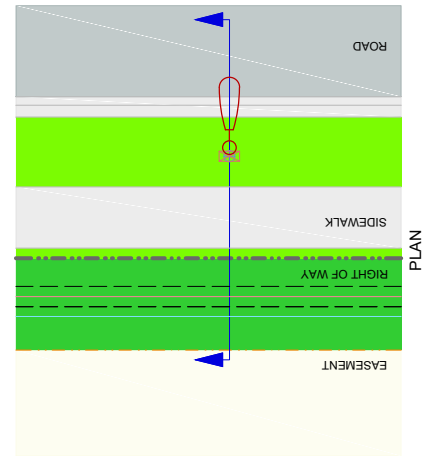
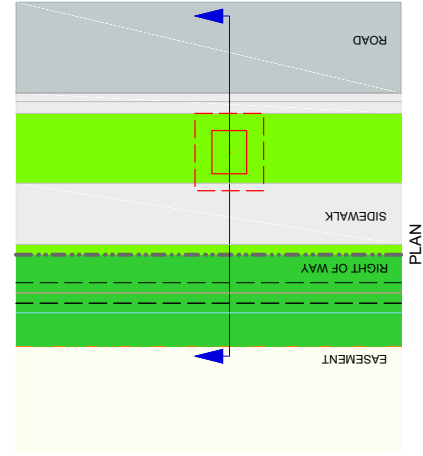
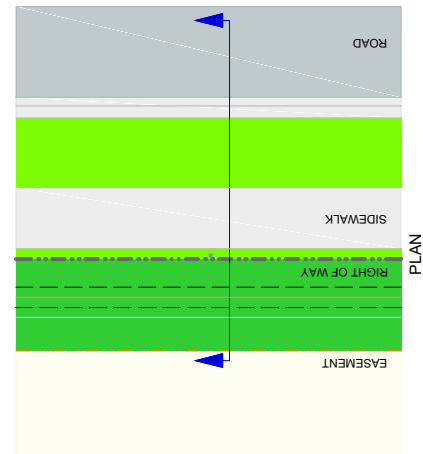
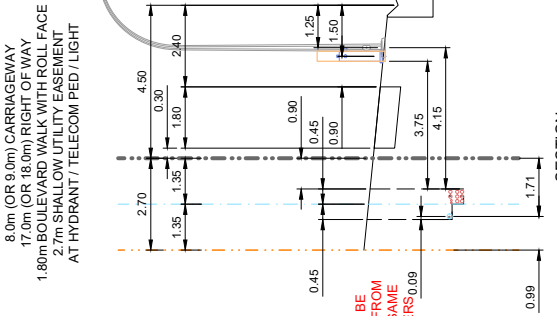
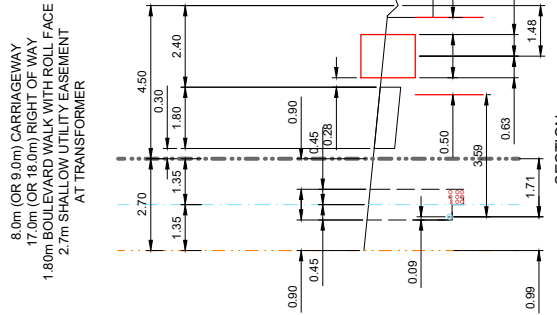
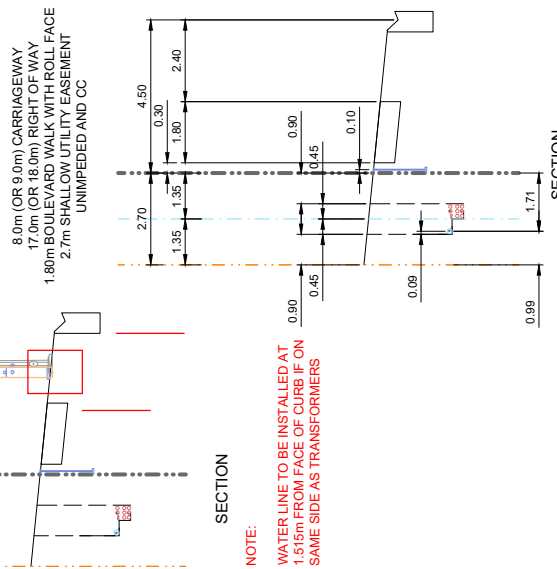
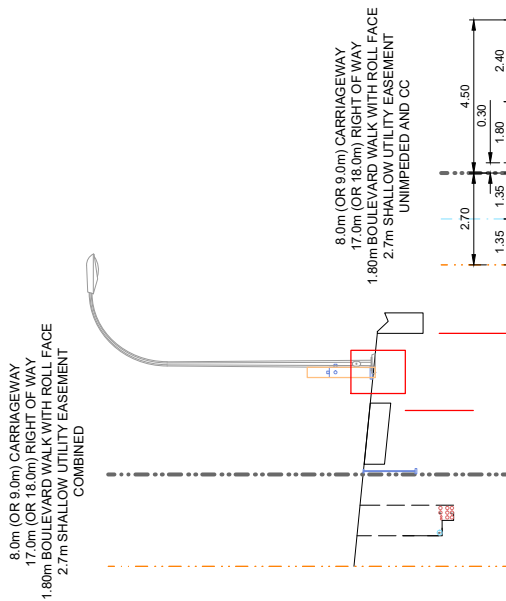

**ALL DIMENSIONS
IN METRES UNLESS
OTHERWISE NOTED**

**LOCAL ROAD BOULEVARD DETAILS
4.50m BLVD & 1.800m BLVD WALK
2.7m MULTI PARTY EASEMENT**



STANDARD DRAWING

DATE APPROVED: **2025**

SCALE: **N.T.S.**

DRAWN BY: **NH**

CHECKED BY: **JN**

APPROVED:

DRAWING NUMBER: **2296B**

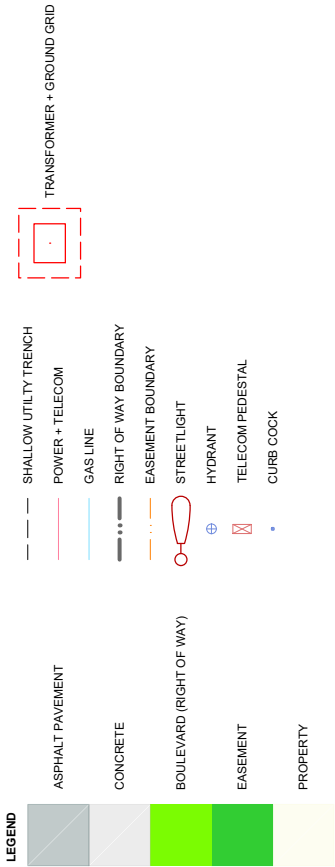

8.0m (OR 9.0m) CARRIAGEWAY
17.0m (OR 18.0m) RIGHT OF WAY
2.175m ROLL FACE MONOWALK
2.0m GAS EASEMENT
COMBINED

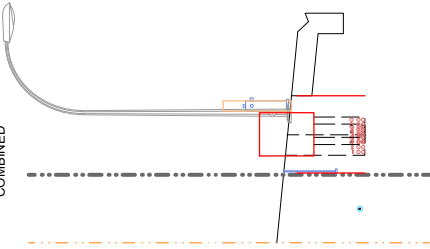

SECTION

NOTE:
SHALLOW UTILITY TRENCH
MEANDERS AT
TRANSFORMERS AND
HYDRANTS/TELECOM LIGHTS.

8.0m (OR 9.0m) CARRIAGEWAY
17.0m (OR 18.0m) RIGHT OF WAY
2.175m ROLL FACE MONOWALK
2.0m GAS EASEMENT
UNIMPEDED AND CC

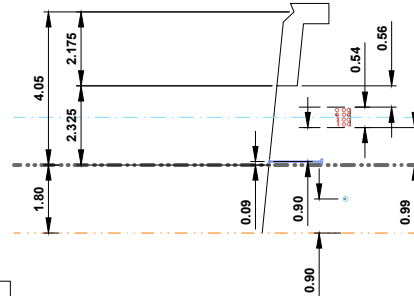

SECTION

8.0m (OR 9.0m) CARRIAGEWAY
17.0m (OR 18.0m) RIGHT OF WAY
2.175m ROLL FACE MONOWALK
2.0m GAS EASEMENT
AT TRANSFORMER

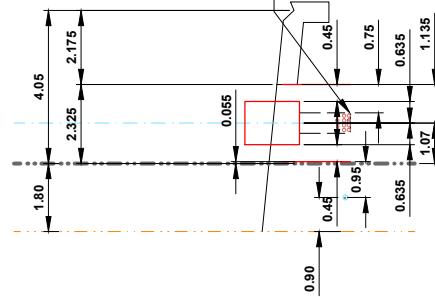

SECTION

MECHANICAL
PROTECTION
REQUIRED AT
GROUND GRID

8.0m (OR 9.0m) CARRIAGEWAY
17.0m (OR 18.0m) RIGHT OF WAY
2.175m ROLL FACE MONOWALK
2.0m GAS EASEMENT
AT HYDRANT / TELECOM PED / LIGHT

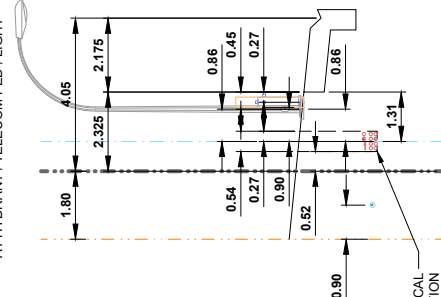

SECTION

NOTE: SHALLOW UTILITY
TRENCH MEANDERS AROUND
TRANSFORMERS AND
HYDRANTS

MECHANICAL
PROTECTION
REQUIRED AT
HYDRANT

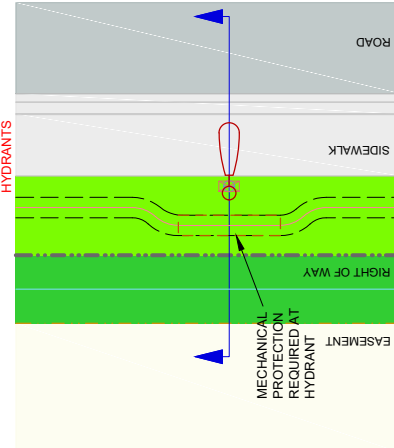

PLAN

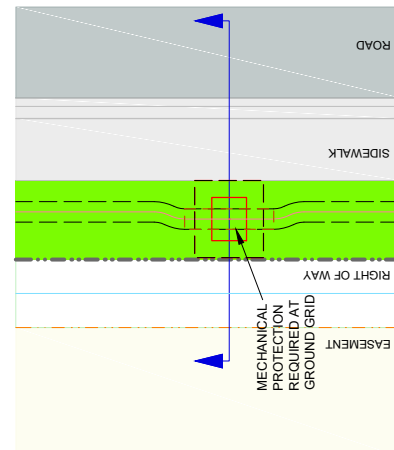

PLAN

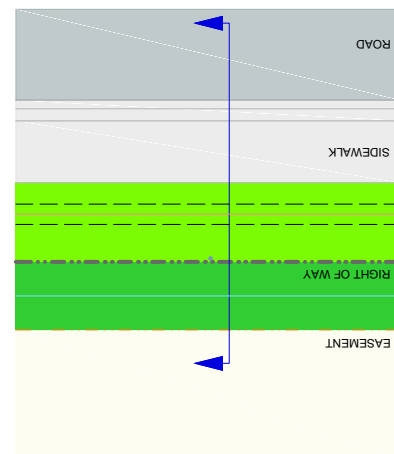

PLAN

ALL DIMENSIONS
IN METRES UNLESS
OTHERWISE NOTED



STANDARD DRAWING

LOCAL ROAD BOULEVARD DETAILS
4.50m BLVD & 2.175m MONO WALK
2.0m GAS EASEMENT

DATE APPROVED: **2025**

DRAWN BY: **NH**

APPROVED: *[Signature]*

DRAWING NUMBER: **2297A**

SCALE: **N.T.S.**

CHECKED BY: **JN**

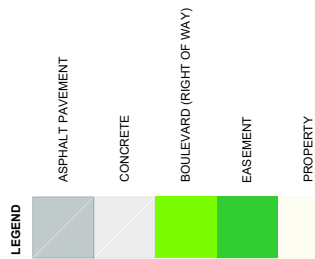
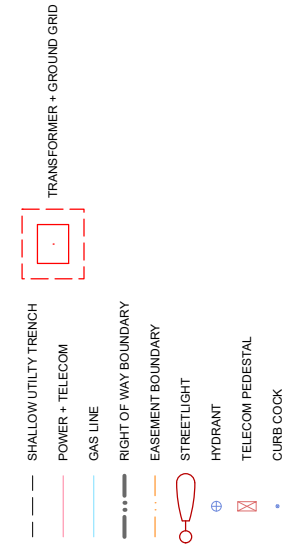

8.0m (OR 9.0m) CARRIAGEWAY
17.0m (OR 18.0m) RIGHT OF WAY
2.175m ROLL FACE MONOWALK
2.7m SHALLOW UTILITY EASEMENT
COMBINED

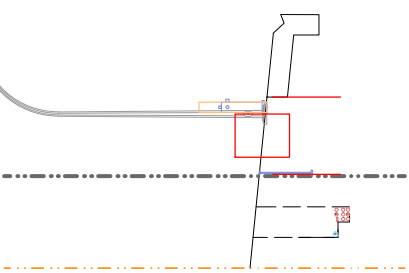

SECTION

8.0m (OR 9.0m) CARRIAGEWAY
17.0m (OR 18.0m) RIGHT OF WAY
12.175m ROLL FACE MONOWALK
2.7m SHALLOW UTILITY EASEMENT
UNIMPEDED AND CC

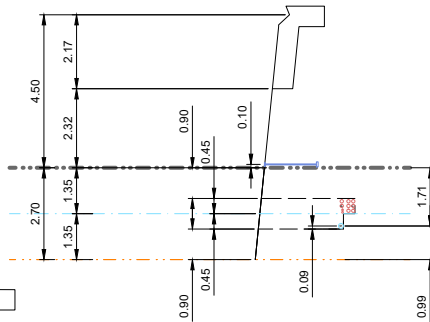

SECTION

8.0m (OR 9.0m) CARRIAGEWAY
17.0m (OR 18.0m) RIGHT OF WAY
2.175m ROLL FACE MONOWALK
2.7m SHALLOW UTILITY EASEMENT
AT TRANSFORMER

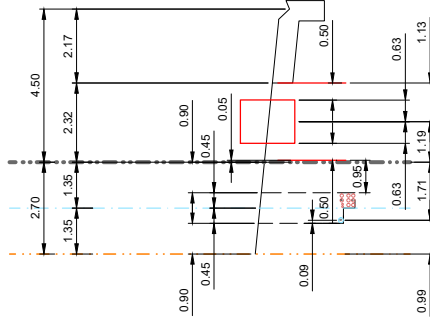

SECTION

8.0m (OR 9.0m) CARRIAGEWAY
17.0m (OR 18.0m) RIGHT OF WAY
2.175m ROLL FACE MONOWALK
2.7m SHALLOW UTILITY EASEMENT
AT HYDRANT / TELECOM PED / LIGHT

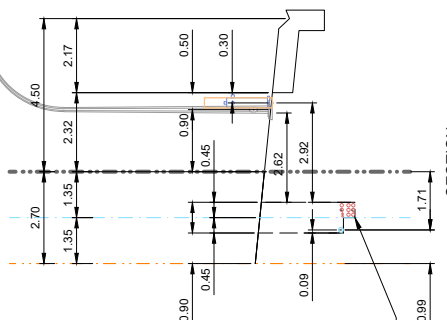

SECTION

MECHANICAL PROTECTION REQUIRED AT HYDRANT

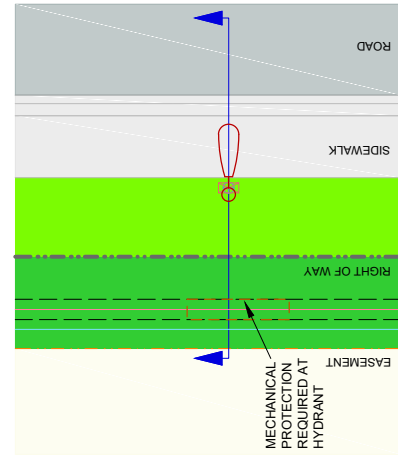

PLAN

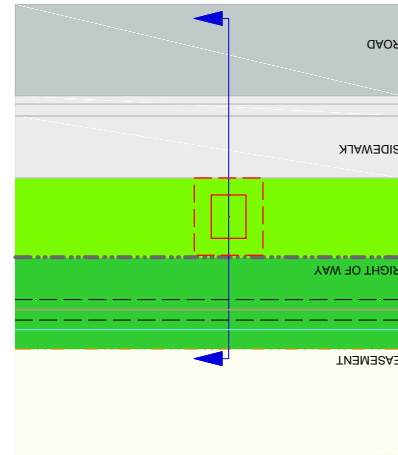

PLAN

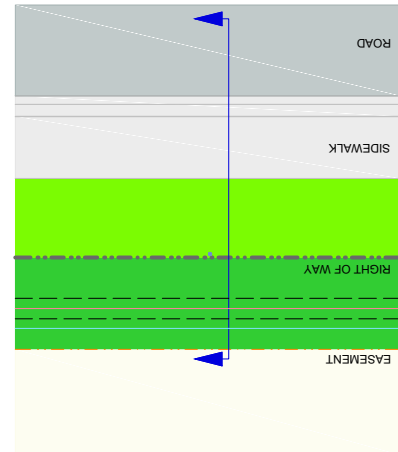

PLAN

**ALL DIMENSIONS
IN METRES UNLESS
OTHERWISE NOTED**

**LOCAL ROAD BOULEVARD DETAILS
4.50m BLVD & 2.175m MONO WALK
2.7m MULTI PARTY EASEMENT**



STANDARD DRAWING

DATE APPROVED: **2025**

SCALE: **N.T.S.**

DRAWN BY: **NH**

CHECKED BY: **JN**

APPROVED: *[Signature]*

DRAWING NUMBER: **2297B**

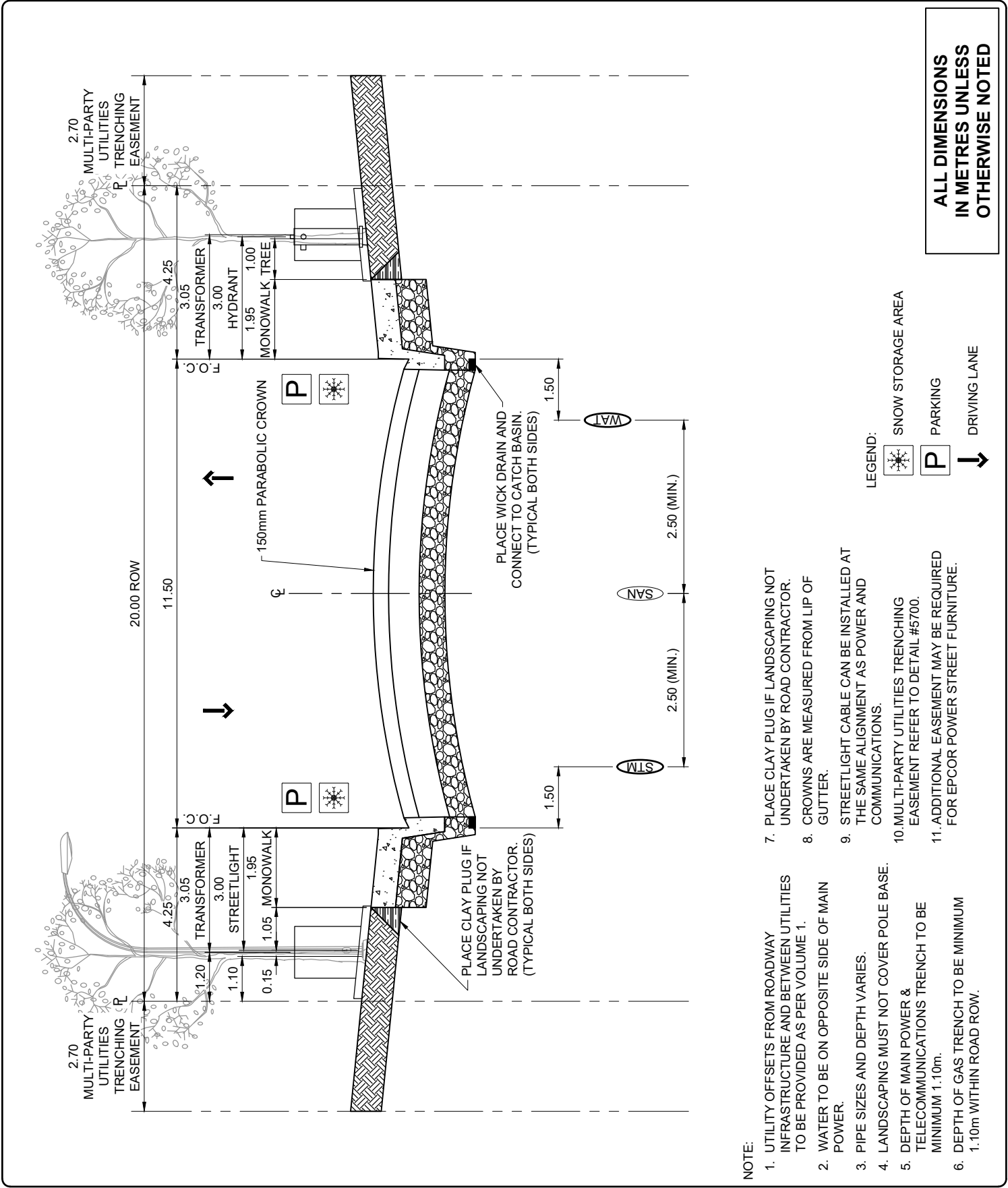

ALL DIMENSIONS IN METRES UNLESS OTHERWISE NOTED

STANDARD DRAWING

11.50m INDUSTRIAL LOCAL (MONOWALK) - 20.00m ROW

DATE APPROVED: 2025	DRAWN BY: FR	APPROVED:	DRAWING NUMBER: 2300
SCALE: N.T.S.	CHECKED BY: JN		

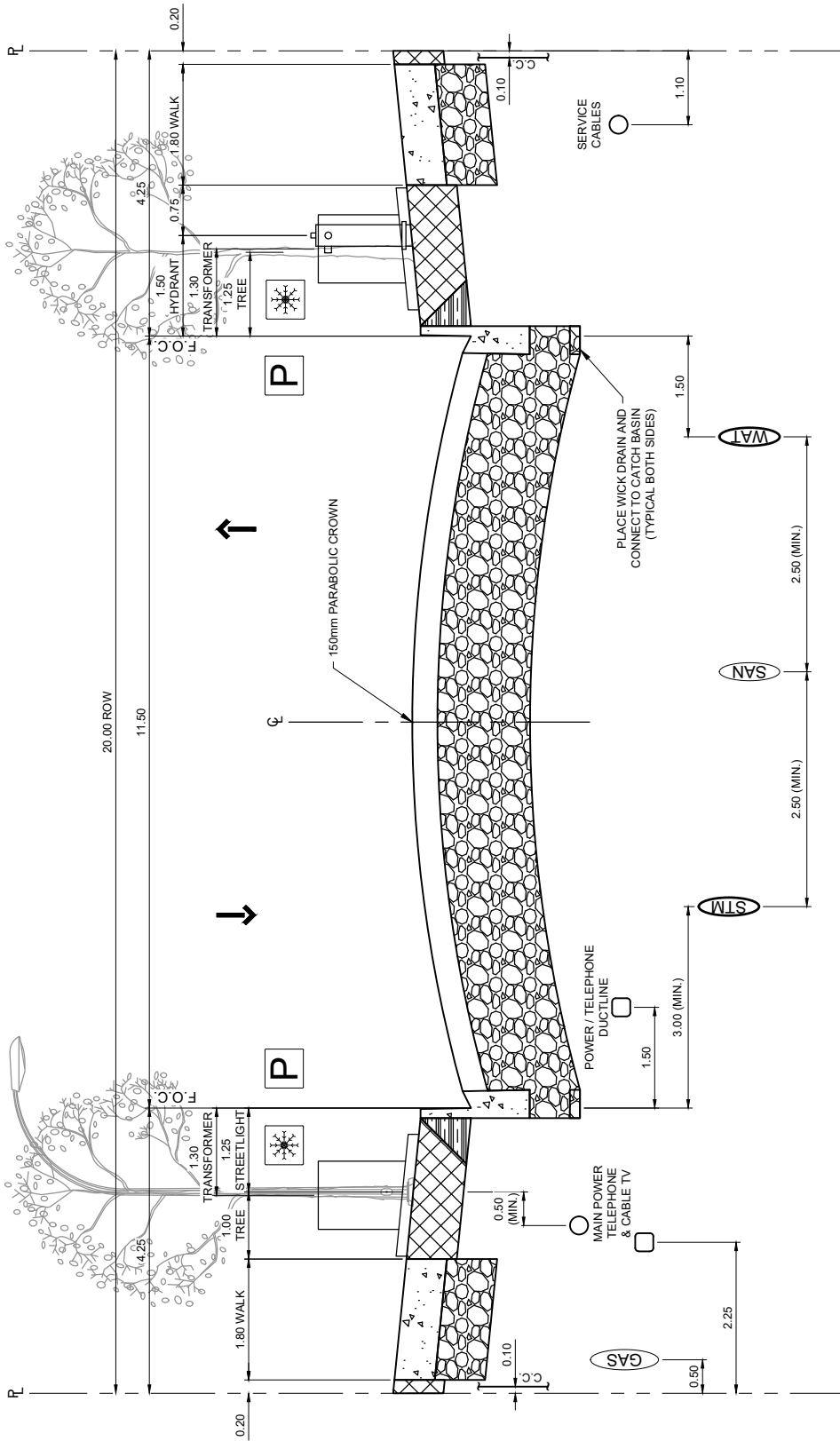

NOTE:

1. UTILITY OFFSETS FROM ROADWAY INFRASTRUCTURE AND BETWEEN UTILITIES TO BE PROVIDED AS PER VOLUME 1.
2. WATER TO BE ON OPPOSITE SIDE OF MAIN POWER.
3. PIPE SIZES AND DEPTH VARIES.
4. LANDSCAPING MUST NOT COVER POLE BASE.
5. DEPTH OF MAIN POWER & TELECOMMUNICATIONS TRENCH TO BE MINIMUM 1.10m.
6. DEPTH OF GAS TRENCH TO BE MINIMUM 1.10m WITHIN ROAD ROW.
7. PLACE CLAY PLUG IF LANDSCAPING NOT UNDERTAKEN BY ROAD CONTRACTOR.
8. CROWNS ARE MEASURED FROM LIP OF GUTTER.
9. STREETLIGHT CABLE CAN BE INSTALLED AT THE SAME ALIGNMENT AS POWER AND COMMUNICATIONS.
10. MULTI-PARTY UTILITIES TRENCHING EASEMENT REFER TO DETAIL #5700.
11. ADDITIONAL EASEMENT MAY BE REQUIRED FOR EPCOR POWER STREET FURNITURE.

LEGEND:

- SNOW STORAGE AREA
- PARKING
- DRIVING LANE

**ALL DIMENSIONS
IN METRES UNLESS
OTHERWISE NOTED**

STANDARD DRAWING

11.50m INDUSTRIAL LOCAL (BOULEVARD WALK) - 20.00m ROW

DATE APPROVED: **2025**
SCALE: **N.T.S.**

DRAWN BY: **FR**
CHECKED BY: **JN**

APPROVED:

DRAWING NUMBER: **2310**

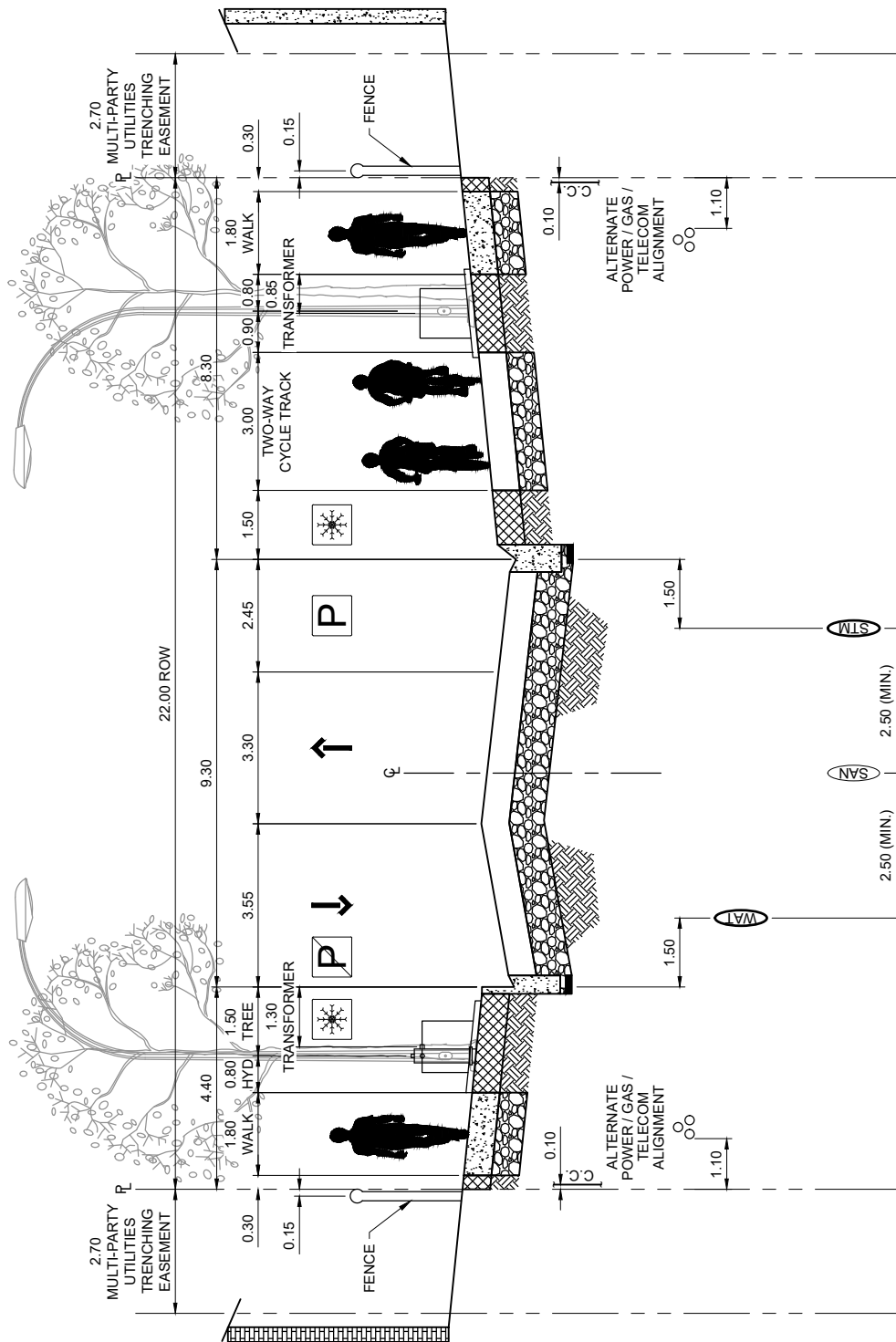

NOTE:

- UTILITY OFFSETS FROM ROADWAY INFRASTRUCTURE AND BETWEEN UTILITIES TO BE PROVIDED AS PER VOLUME 1.
- WATER TO BE ON OPPOSITE SIDE OF MAIN POWER.
- PIPE SIZES AND DEPTH VARIES.
- LANDSCAPING MUST NOT COVER POLE BASE.
- DEPTH OF MAIN POWER & TELECOMMUNICATIONS TRENCH TO BE MINIMUM 1.10m.
- DEPTH OF GAS TRENCH TO BE MINIMUM 1.10m WITHIN ROAD ROW.
- GAS MAIN LOCATED ON EASEMENTS.
- PLACE CLAY PLUG IF LANDSCAPING NOT UNDERTAKEN BY ROAD CONTRACTOR.
- CROWNS ARE MEASURED FROM LIP OF GUTTER.
- STREETLIGHT CABLE CAN BE INSTALLED AT THE SAME ALIGNMENT AS POWER AND COMMUNICATIONS.
- WHERE APPLICABLE, MULTI-PARTY UTILITIES TRENCHING EASEMENT REFER TO DETAIL #5700.
- ADDITIONAL EASEMENT MAY BE REQUIRED FOR EPCOR POWER STREET FURNITURE.

LEGEND:

- SNOW STORAGE AREA
- PARKING
- NO PARKING
- DRIVING LANE

**ALL DIMENSIONS
IN METRES UNLESS
OTHERWISE NOTED**

Edmonton

STANDARD DRAWING

9.30m COLLECTOR WITH CYCLE TRACK - 22.0m ROW

DATE APPROVED: **2025**

DRAWN BY: **FR**

APPROVED:

DRAWING NUMBER: **2325**

SCALE: **N.T.S.**

CHECKED BY: **JN**

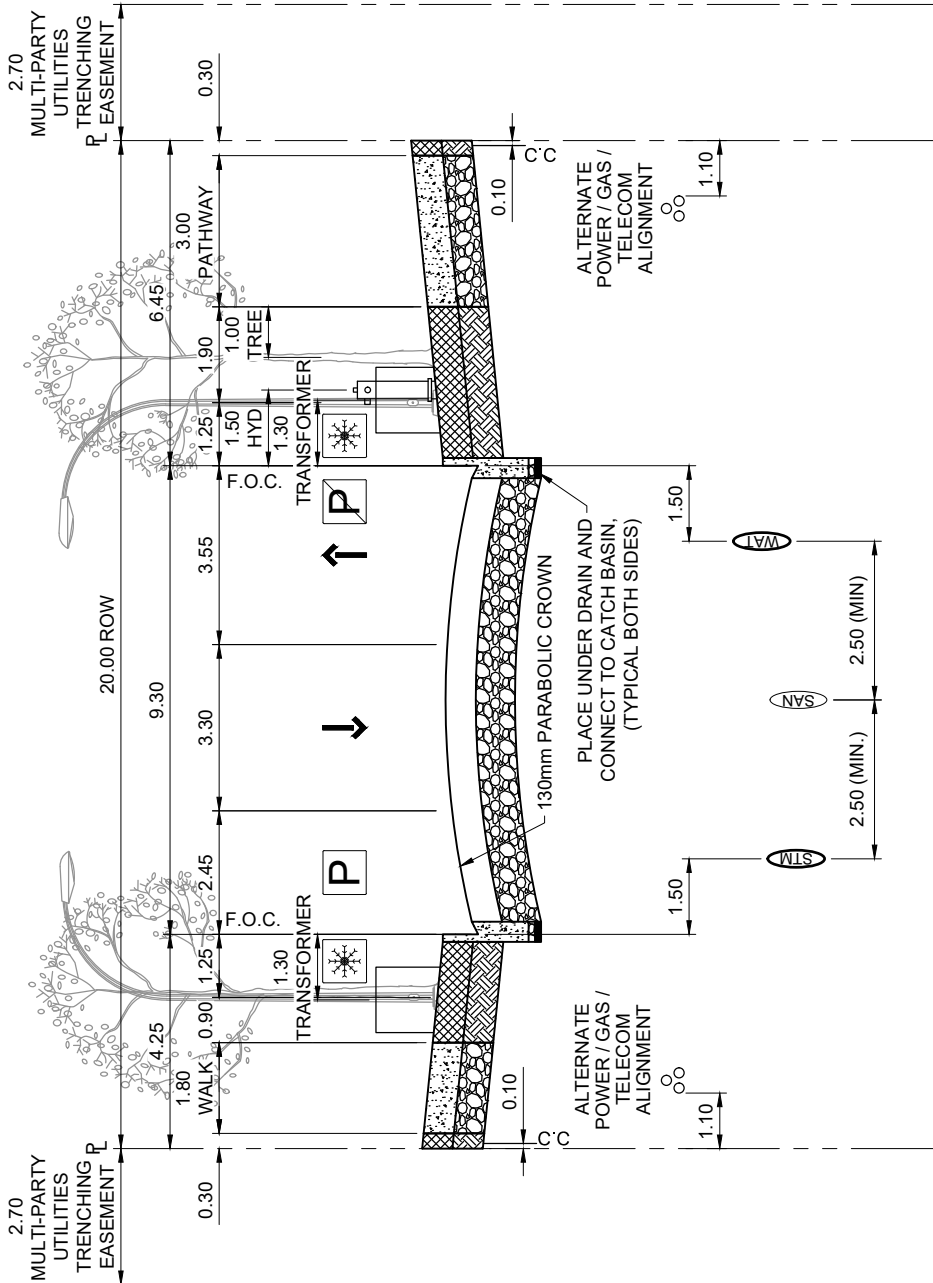

BASE COLLECTOR B

BASE COLLECTOR A

NOTE:

1. UTILITY OFFSETS FROM ROADWAY INFRASTRUCTURE AND BETWEEN UTILITIES TO BE PROVIDED AS PER VOLUME 1.
2. WATER TO BE ON OPPOSITE SIDE OF MAIN POWER.
3. PIPE SIZES AND DEPTH VARIES.
4. LANDSCAPING MUST NOT COVER POLE BASE.
5. DEPTH OF MAIN POWER & TELECOMMUNICATIONS TRENCH TO BE MINIMUM 1.10m.
6. DEPTH OF GAS TRENCH TO BE MINIMUM 1.10m WITHIN ROAD ROW.
7. PLACE CLAY PLUG IF LANDSCAPING NOT UNDERTAKEN BY ROAD CONTRACTOR.
8. CROWNS ARE MEASURED FROM LIP OF GUTTER.
9. STREETLIGHT CABLE CAN BE INSTALLED AT THE SAME ALIGNMENT AS POWER AND COMMUNICATIONS.
10. WHERE APPLICABLE, MULTI-PARTY UTILITIES TRENCHING EASEMENT REFER TO DETAIL #5700.

LEGEND:

- SNOW STORAGE AREA
- PARKING
- NO PARKING
- DRIVING LANE

**REFER TO DETAILS
2331, 2332, & 2333
FOR ALTERNATIVE BLVD
CONFIGURATIONS**

**ALL DIMENSIONS
IN METRES UNLESS
OTHERWISE NOTED**

9.30m BASE COLLECTOR - 20.00m ROW



STANDARD DRAWING

DATE APPROVED: **2025**

DRAWN BY: **FR**

APPROVED:

DRAWING NUMBER: **2330**

SCALE: **N.T.S.**

CHECKED BY: **JN**

REFER TO DETAILS
2331, 2332, & 2333
FOR ALTERNATIVE BLVD
CONFIGURATIONS

ALL DIMENSIONS
IN METRES UNLESS
OTHERWISE NOTED

LEGEND:

- SNOW STORAGE AREA
- PARKING
- DRIVING LANE

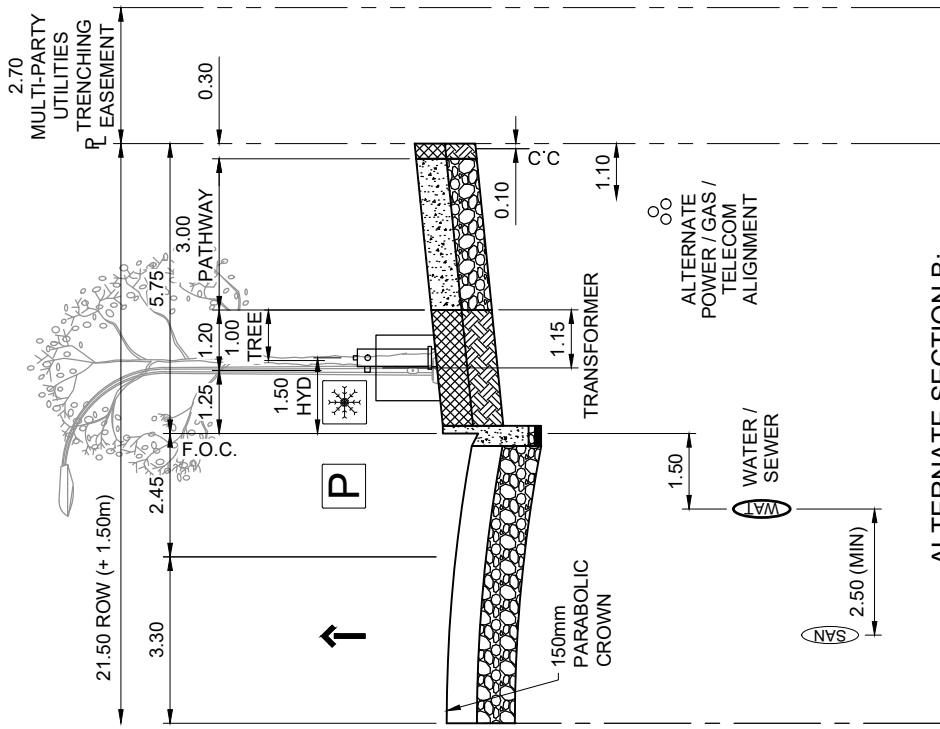

ALTERNATE SECTION B:
PARKING ON PATHWAY SIDE

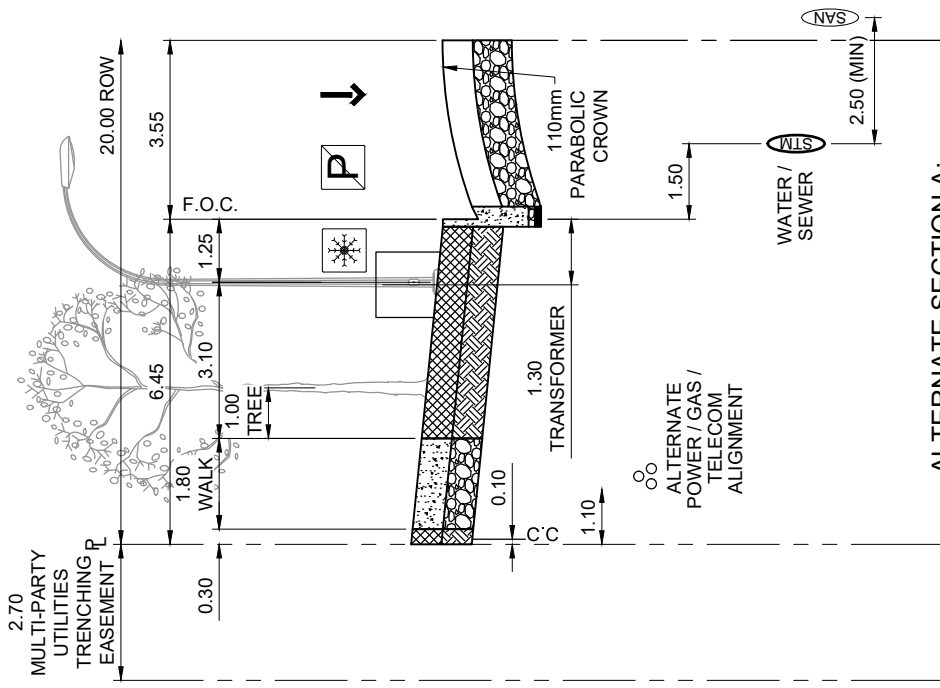

ALTERNATE SECTION A:
NO PARKING

STANDARD DRAWING

ALTERNATE COLLECTOR BOULEVARDS A AND B

DATE APPROVED: **2025**
SCALE: **N.T.S.**

DRAWN BY: **FR**
CHECKED BY: **JN**

APPROVED:

DRAWING NUMBER: **2331**

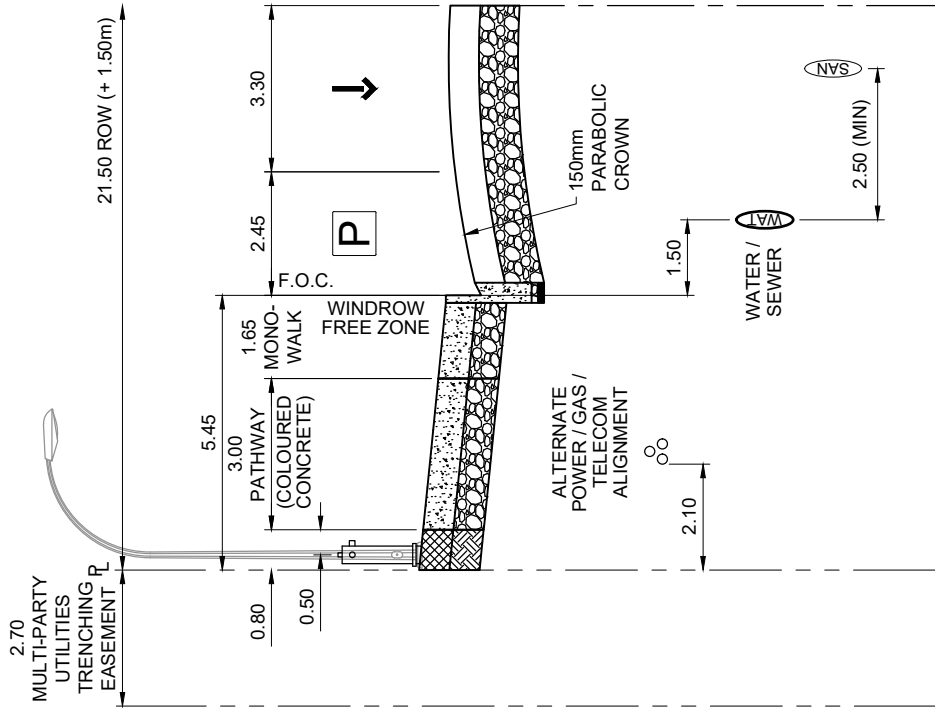

ALTERNATE SECTION D:
SCHOOL SITE WITH OPPOSITE SIDE SUP
REQUIRES BASE A OR ALTERNATE B OPPOSITE

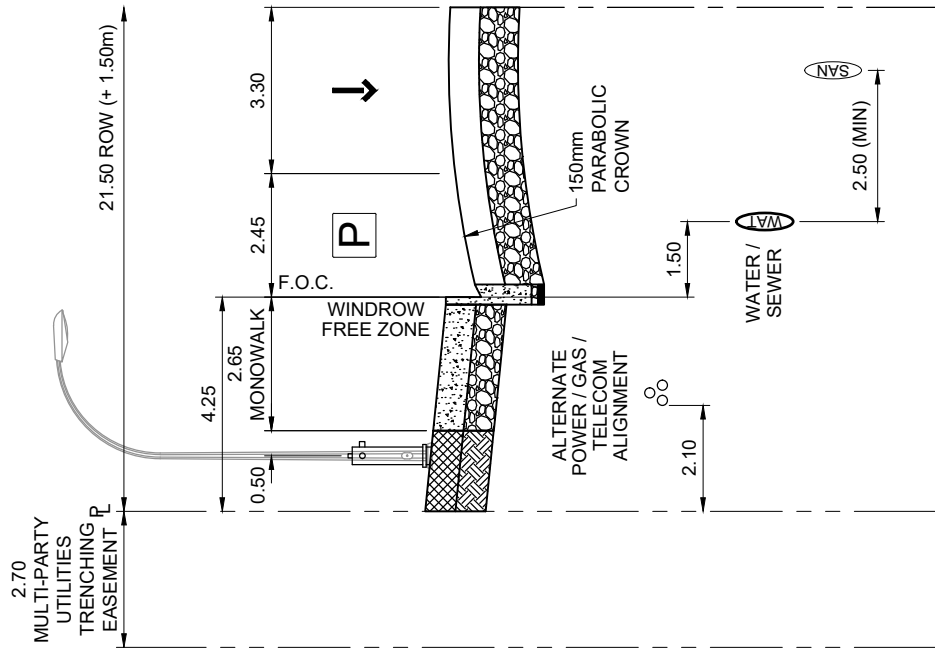

ALTERNATE SECTION C:
SCHOOL SITE WITH OPPOSITE SIDE SUP
REQUIRES ALTERNATE B OPPOSITE

NOTE: SCHOOL SITE REQUIRES
PROVISION OF PARKING ON BOTH SIDES

REFER TO DETAILS
2331, 2332, & 2333
FOR ALTERNATIVE BLVD
CONFIGURATIONS

ALL DIMENSIONS
IN METRES UNLESS
OTHERWISE NOTED

LEGEND:

- SNOW STORAGE AREA
- PARKING
- DRIVING LANE



STANDARD DRAWING

ALTERNATE COLLECTOR BOULEVARDS C AND D (SCHOOL SITE)

DATE APPROVED: **2025**
SCALE: **N.T.S.**

DRAWN BY: **FR**
CHECKED BY: **JN**

APPROVED:

DRAWING NUMBER: **2332**

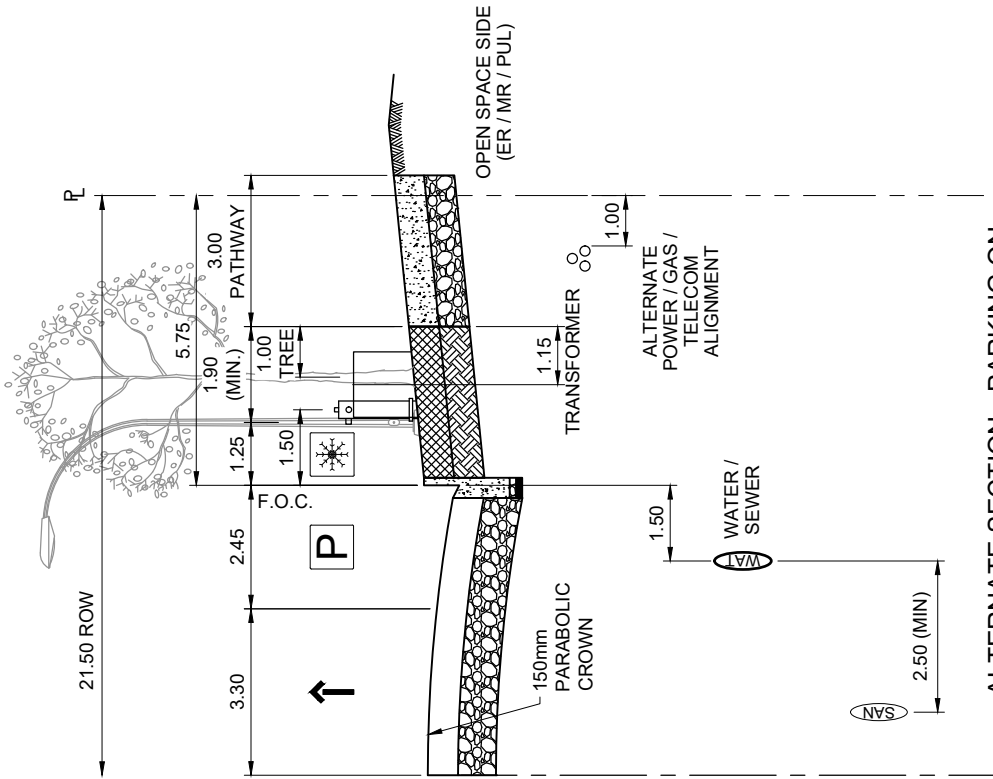

ALTERNATE SECTION - PARKING ON PATHWAY ADJACENT TO OPEN SPACE

REFER TO DETAILS 2331, 2332, & 2333 FOR ALTERNATIVE BLVD CONFIGURATIONS

ALL DIMENSIONS IN METRES UNLESS OTHERWISE NOTED

LEGEND:

- SNOW STORAGE AREA
- PARKING
- DRIVING LANE

NOTE:

1. PATHWAY PERMITTED TO EXTEND INTO MR/ER ONLY WHERE A PARALLEL FACILITY WOULD OTHERWISE EXIST TO ELIMINATE DUPLICATION OF INFRASTRUCTURE



STANDARD DRAWING

ALTERNATE COLLECTOR BOULEVARDS E (OPEN SPACE)

DATE APPROVED: **2025**

DRAWN BY: **FR**

APPROVED:

DRAWING NUMBER: **2333**

SCALE: **N.T.S.**

CHECKED BY: **JN**

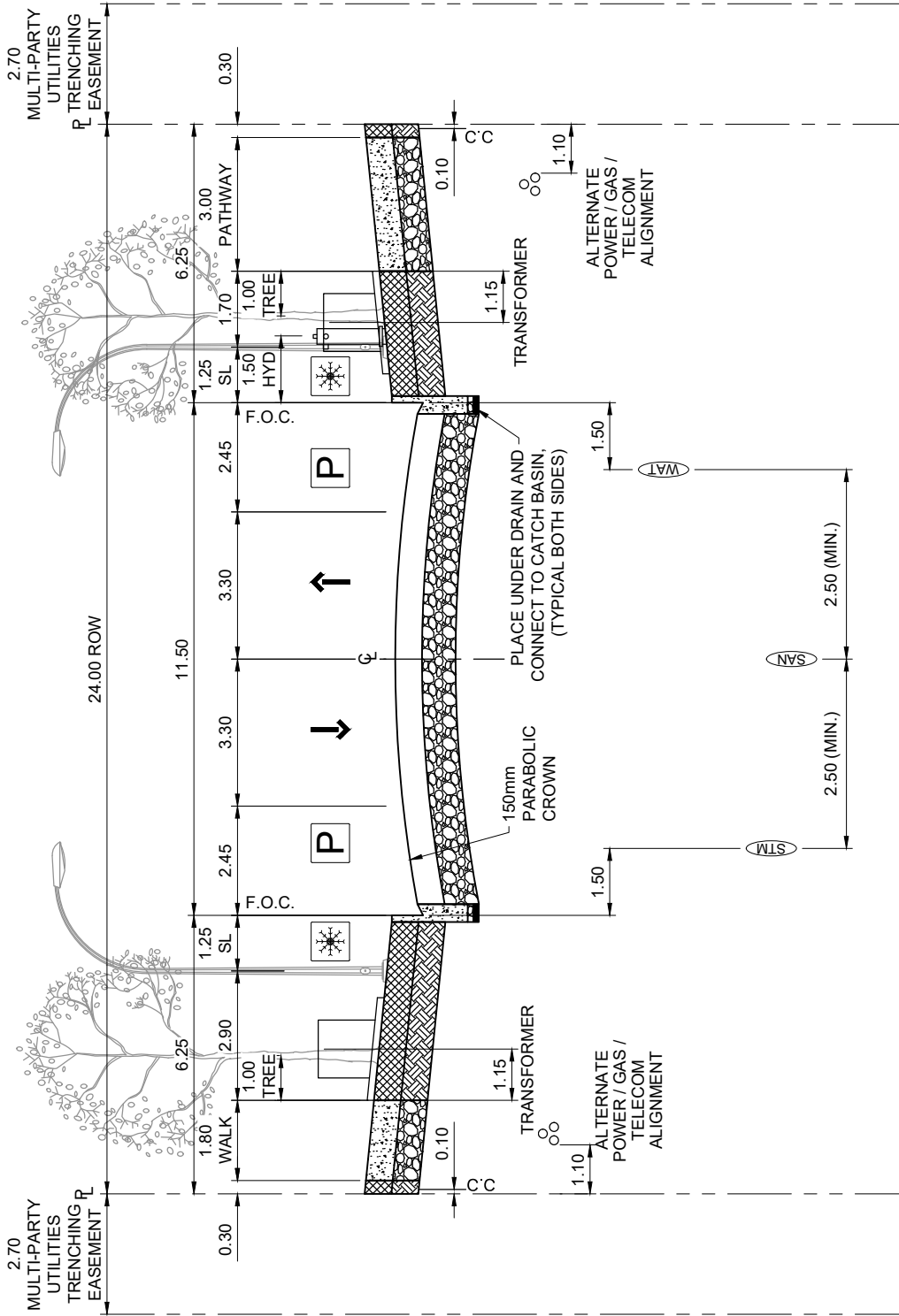

NOTE:

- UTILITY OFFSETS FROM ROADWAY INFRASTRUCTURE AND BETWEEN UTILITIES TO BE PROVIDED AS PER VOLUME 1.
- WATER TO BE ON OPPOSITE SIDE OF MAIN POWER.
- PIPE SIZES AND DEPTH VARIES.
- LANDSCAPING MUST NOT COVER POLE BASE.
- DEPTH OF MAIN POWER & TELECOMMUNICATIONS TRENCH TO BE MINIMUM 1.10m.
- DEPTH OF GAS TRENCH TO BE MINIMUM 1.10m WITHIN ROAD ROW.
- PLACE CLAY PLUG IF LANDSCAPING NOT UNDERTAKEN BY ROAD CONTRACTOR.
- CROWNS ARE MEASURED FROM LIP OF GUTTER.
- STREETLIGHT CABLE CAN BE INSTALLED AT THE SAME ALIGNMENT AS POWER AND COMMUNICATIONS.
- WHERE APPLICABLE, MULTI-PARTY UTILITIES TRENCHING EASEMENT REFER TO DETAIL #5700.

LEGEND:

- SNOW STORAGE AREA
- PARKING
- DRIVING LANE

ALL DIMENSIONS IN METRES UNLESS OTHERWISE NOTED

STANDARD DRAWING

11.50m COLLECTOR WITH PATHWAY - 24.00m ROW

DATE APPROVED: 2025	DRAWN BY: FR	APPROVED: 	DRAWING NUMBER: 2345
SCALE: N.T.S.	CHECKED BY: JN		

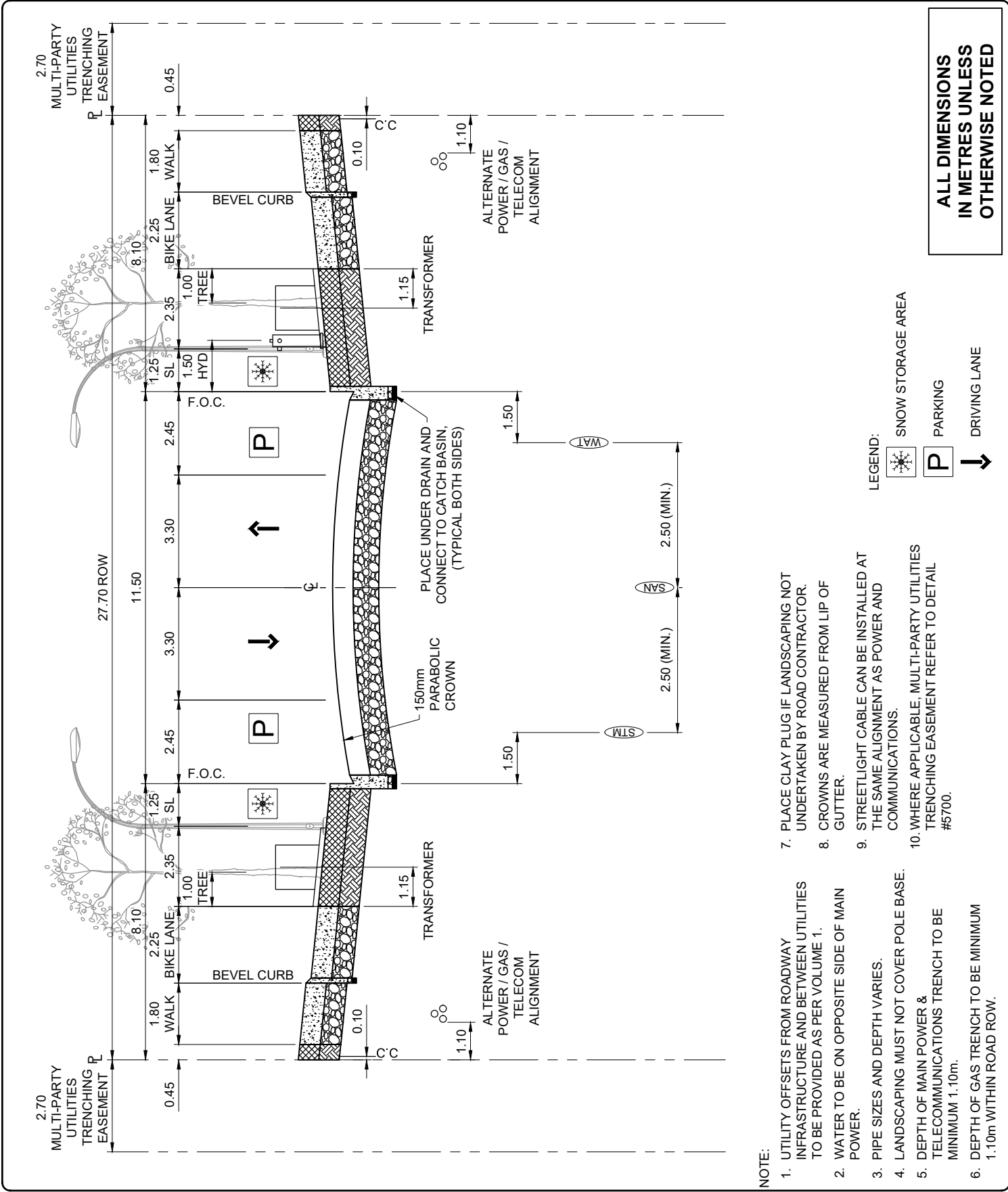

**ALL DIMENSIONS
IN METRES UNLESS
OTHERWISE NOTED**

- NOTE:**
- UTILITY OFFSETS FROM ROADWAY INFRASTRUCTURE AND BETWEEN UTILITIES TO BE PROVIDED AS PER VOLUME 1.
 - WATER TO BE ON OPPOSITE SIDE OF MAIN POWER.
 - PIPE SIZES AND DEPTH VARIES.
 - LANDSCAPING MUST NOT COVER POLE BASE.
 - DEPTH OF MAIN POWER & TELECOMMUNICATIONS TRENCH TO BE MINIMUM 1.10m.
 - DEPTH OF GAS TRENCH TO BE MINIMUM 1.10m WITHIN ROAD ROW.
 - PLACE CLAY PLUG IF LANDSCAPING NOT UNDERTAKEN BY ROAD CONTRACTOR.
 - CROWNS ARE MEASURED FROM LIP OF GUTTER.
 - STREETLIGHT CABLE CAN BE INSTALLED AT THE SAME ALIGNMENT AS POWER AND COMMUNICATIONS.
 - WHERE APPLICABLE, MULTI-PARTY UTILITIES TRENCHING EASEMENT REFER TO DETAIL #5700.

LEGEND:

- SNOW STORAGE AREA
- PARKING
- DRIVING LANE

STANDARD DRAWING

11.50m COLLECTOR WITH BIKE LANES - 27.70m ROW

DATE APPROVED: 2025	DRAWN BY: FR	APPROVED: 	DRAWING NUMBER: 2346
SCALE: N.T.S.	CHECKED BY: JN		

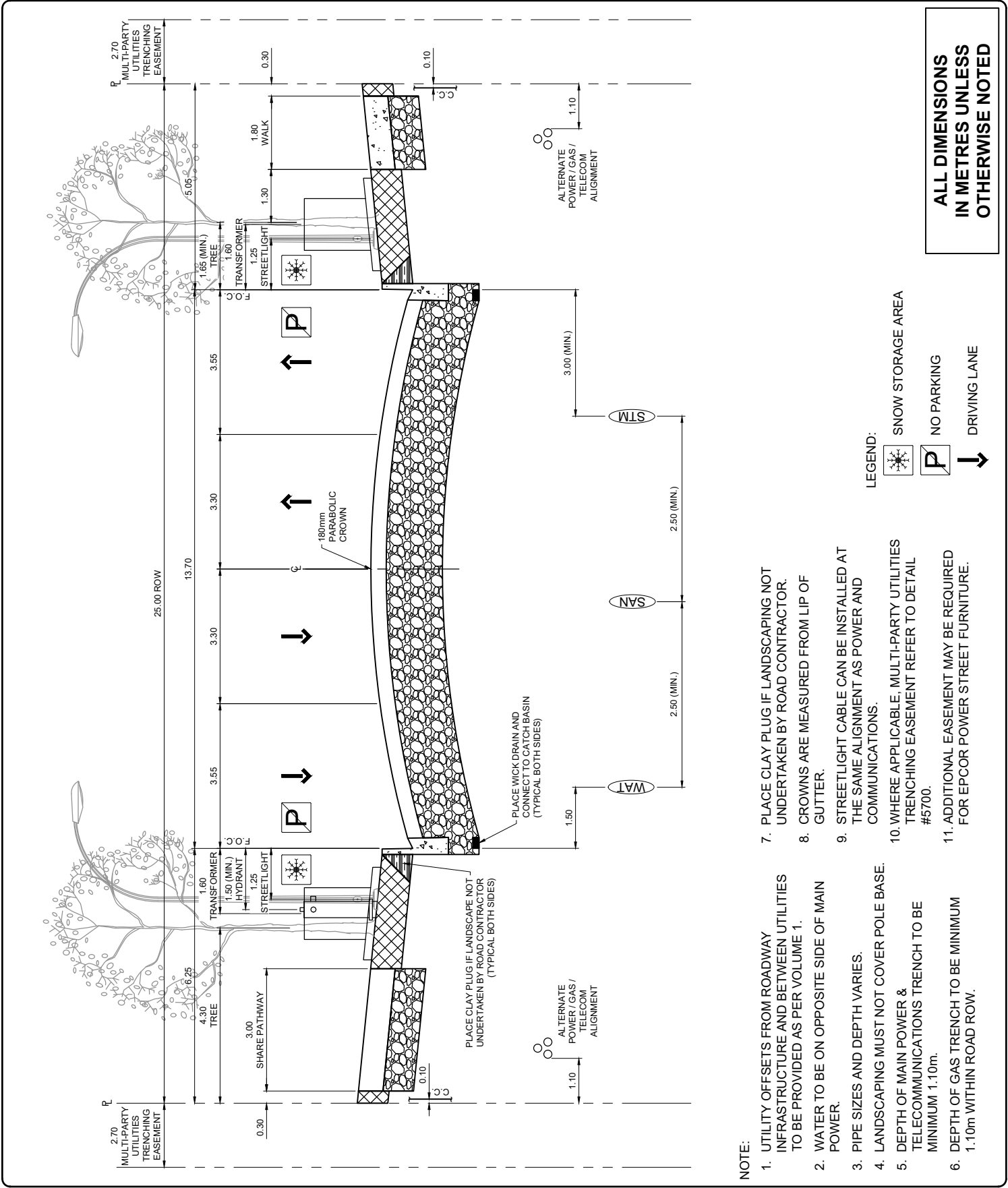

STANDARD DRAWING

13.70 FOUR LANE COLLECTOR - 25.0m ROW

DATE APPROVED: 2025	DRAWN BY: FR	APPROVED: 	DRAWING NUMBER: 2410
SCALE: N.T.S.	CHECKED BY: JN		

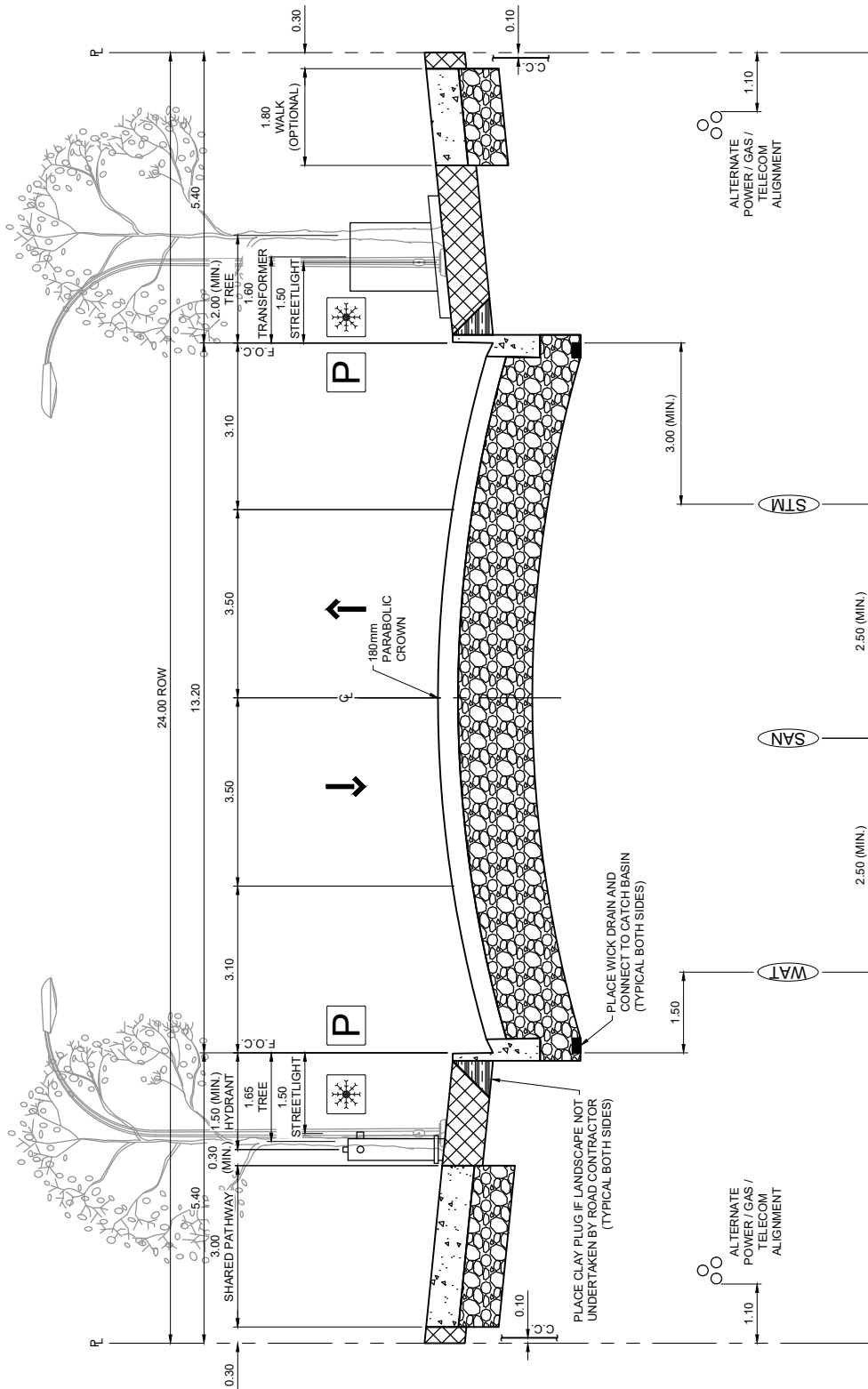

NOTE:

1. UTILITY OFFSETS FROM ROADWAY INFRASTRUCTURE AND BETWEEN UTILITIES TO BE PROVIDED AS PER VOLUME 1.
2. WATER TO BE ON OPPOSITE SIDE OF MAIN POWER.
3. PIPE SIZES AND DEPTH VARIES.
4. LANDSCAPING MUST NOT COVER POLE BASE.
5. DEPTH OF MAIN POWER & TELECOMMUNICATIONS TRENCH TO BE MINIMUM 1.10m.
6. DEPTH OF GAS TRENCH TO BE MINIMUM 1.10m WITHIN ROAD ROW.

7. PLACE CLAY PLUG IF LANDSCAPING NOT UNDERTAKEN BY ROAD CONTRACTOR.
8. CROWNS ARE MEASURED FROM LIP OF GUTTER.
9. STREETLIGHT CABLE CAN BE INSTALLED AT THE SAME ALIGNMENT AS POWER AND COMMUNICATIONS.
10. WHERE APPLICABLE, MULTI-PARTY UTILITIES TRENCHING EASEMENT REFER TO DETAIL #5700.
11. ADDITIONAL EASEMENT MAY BE REQUIRED FOR EPCOR POWER STREET FURNITURE.

LEGEND:

- SNOW STORAGE AREA
- PARKING
- DRIVING LANE

ALL DIMENSIONS IN METRES UNLESS OTHERWISE NOTED



STANDARD DRAWING

13.20m INDUSTRIAL COLLECTOR - 24.00m ROW

DATE APPROVED: **2025**
SCALE: **N.T.S.**

DRAWN BY: **FR**
CHECKED BY: **JN**

APPROVED:

DRAWING NUMBER: **2411**

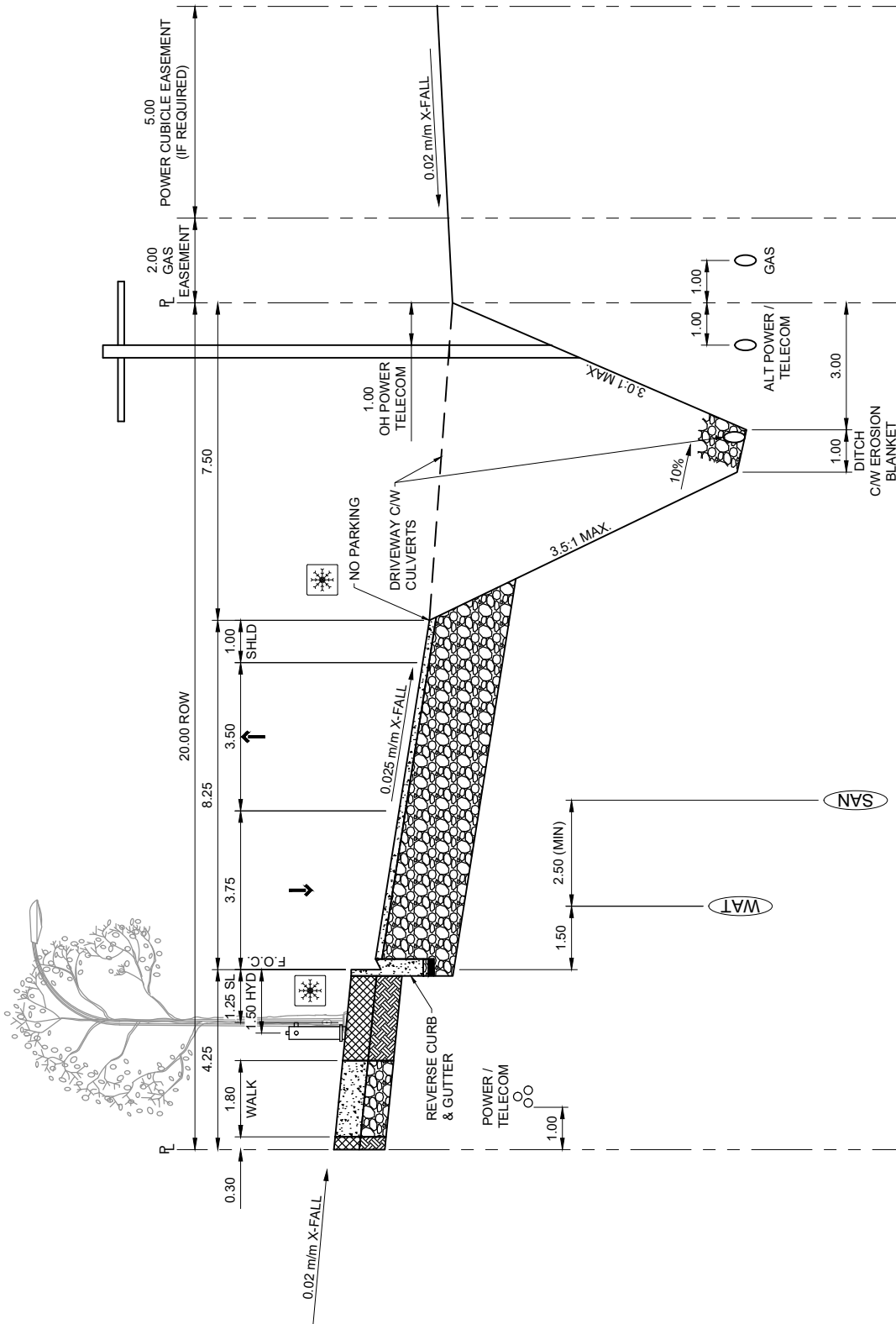

- NOTE:**
1. WATER TO BE ON OPPOSITE SIDE OF MAIN POWER.
 2. PIPE SIZES AND DEPTH VARIES.
 3. LANDSCAPING MUST NOT COVER POLE BASE.
 4. DEPTH OF MAIN POWER, TELEPHONES AND CABLE T.V. TRENCH TO BE MINIMUM 1.10m.
 5. DEPTH OF GAS TRENCH TO BE MINIMUM 1.10m WITHIN ROAD ROW.
 6. REQUIRE A MINIMUM OF 0.30m VERTICAL SEPARATION BETWEEN POWER AND GAS.
 7. MINIMUM OF 1.00m SEPARATION BETWEEN BACK OF WALK AND POWER.
 8. GAS MAIN LOCATED ON EASEMENT.
 9. SERVICE BOX FOR POWER, TELEPHONE AND CABLE T.V. TO STRADDLE PROPERTY LINE.
 10. PLACE CLAY PLUG IF LANDSCAPING NOT UNDERTAKEN BY ROAD CONTRACTOR.
 11. CROWNS ARE MEASURED FROM LIP OF GUTTER.
 12. EASEMENT PROVIDED AS REQUIRED.
 13. SURFACE DRAINAGE TO CONFORM TO THE DRAINAGE BYLAW.
 14. HYDRANT VALVE TO MEET EPCOR WATER MINIMUM SEPARATION REQUIREMENT. WATER VALVE TO BE STRAPPED TO TEE IF CONFLICTING WITH SIDEWALK INFRASTRUCTURE.
 15. STREETLIGHT CABLE CAN BE INSTALLED AT THE SAME ALIGNMENT AS POWER AND COMMUNICATIONS.
 16. WHERE APPLICABLE, MULTI-PARTY UTILITIES TRENCHING EASEMENT REFER TO DETAIL #5700.

LEGEND:

- SNOW STORAGE AREA
- PARKING
- DRIVING LANE

ALL DIMENSIONS IN METRES UNLESS OTHERWISE NOTED

STANDARD DRAWING

8.25m RETROFIT HYBRID INDUSTRIAL COLLECTOR (BOULEVARD WALK) - 20.00m ROW

DATE APPROVED: 2025	DRAWN BY: FR	APPROVED: 	DRAWING NUMBER: 2422
SCALE: N.T.S.	CHECKED BY: JN		

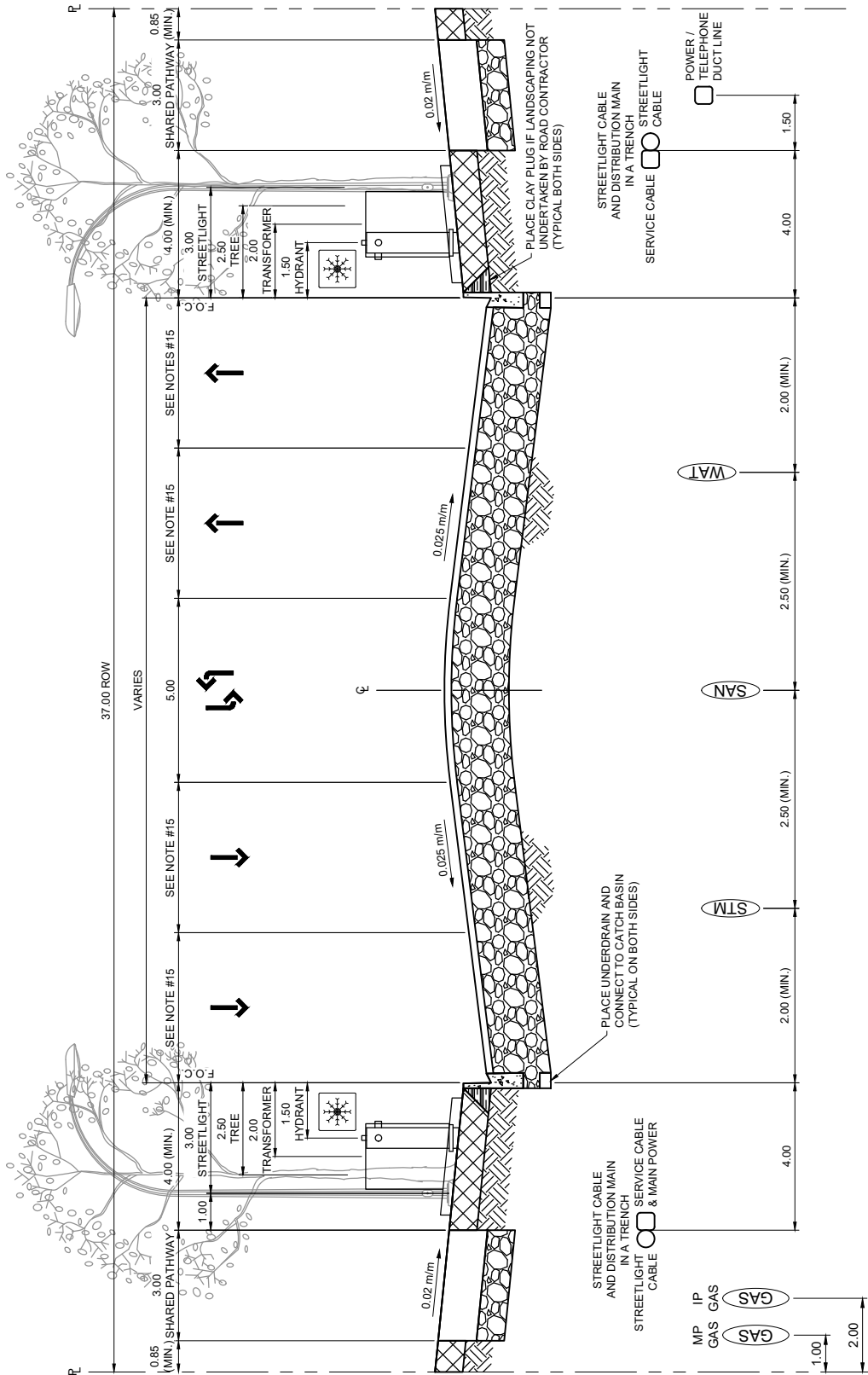

NOTE:

- UTILITY OFFSETS FROM ROADWAY INFRASTRUCTURE AND BETWEEN UTILITIES TO BE PROVIDED AS PER VOLUME 1.
- FRONT DRIVEWAYS ARE NOT PERMITTED.
- WATER TO BE ON OPPOSITE SIDE OF MAIN POWER LINE.
- PIPE SIZES AND DEPTHS MAY VARY.
- LANDSCAPING MUST NOT COVER POLE BASE.
- DEPTH OF MAIN POWER, TELEPHONES AND CABLE T.V. TRENCH TO BE MINIMUM 1.10m.
- DEPTH OF GAS TRENCH TO BE MINIMUM 1.10m WITHIN ROAD ROW.
- CROSS FALLS ARE MEASURED FROM LIP OF GUTTER.
- MAXIMUM SIDESLOPE FROM SHARED PATHWAY TO PROPERTY LINE IS 3.5:1.
- MAXIMUM SIDESLOPE FROM BACK OF CURB TO SHARED PATHWAY IS 10.00%.
- SURFACE DRAINAGE TO CONFORM TO THE DRAINAGE BYLAW.
- LANE WIDTHS BASED ON CONTEXT. REFER TO SECTION 3.2.2.3.
- DEPTH OF GAS TRENCH TO BE MINIMUM 1.10m WITHIN ROAD ROW.
- CROSS FALLS ARE MEASURED FROM LIP OF GUTTER.
- MAXIMUM SIDESLOPE FROM SHARED PATHWAY TO PROPERTY LINE IS 3.5:1.
- MAXIMUM SIDESLOPE FROM BACK OF CURB TO SHARED PATHWAY IS 10.00%.
- SURFACE DRAINAGE TO CONFORM TO THE DRAINAGE BYLAW.
- LANE WIDTHS BASED ON CONTEXT. REFER TO SECTION 3.2.2.3.
- STREETLIGHT CABLE CAN BE INSTALLED AT THE SAME ALIGNMENT AS POWER AND COMMUNICATIONS.
- NOISE ATTENUATION FENCE AS PER DETAIL #5205 ALONG ALL RESIDENTIAL PROPERTY LINES. NOISE BERMS TO BE PROVIDED PER DETAIL #2000 FOR ALL TRUCK ROUTES OR WHERE REQUIRED BASED ON NOISE STUDY.
- SURFACE DRAINAGE TO CONFORM TO DETAILS ON MEDIAN LANDSCAPE TREATMENTS.

LEGEND:

- SNOW STORAGE AREA
- DRIVING LANE

ALL DIMENSIONS IN METRES UNLESS OTHERWISE NOTED

STANDARD DRAWING

FIVE LANE UNDIVIDED ARTERIAL - 37.00m ROW

DATE APPROVED: 2025	DRAWN BY: FR	APPROVED: 	DRAWING NUMBER: 2500
SCALE: N.T.S.	CHECKED BY: JN		

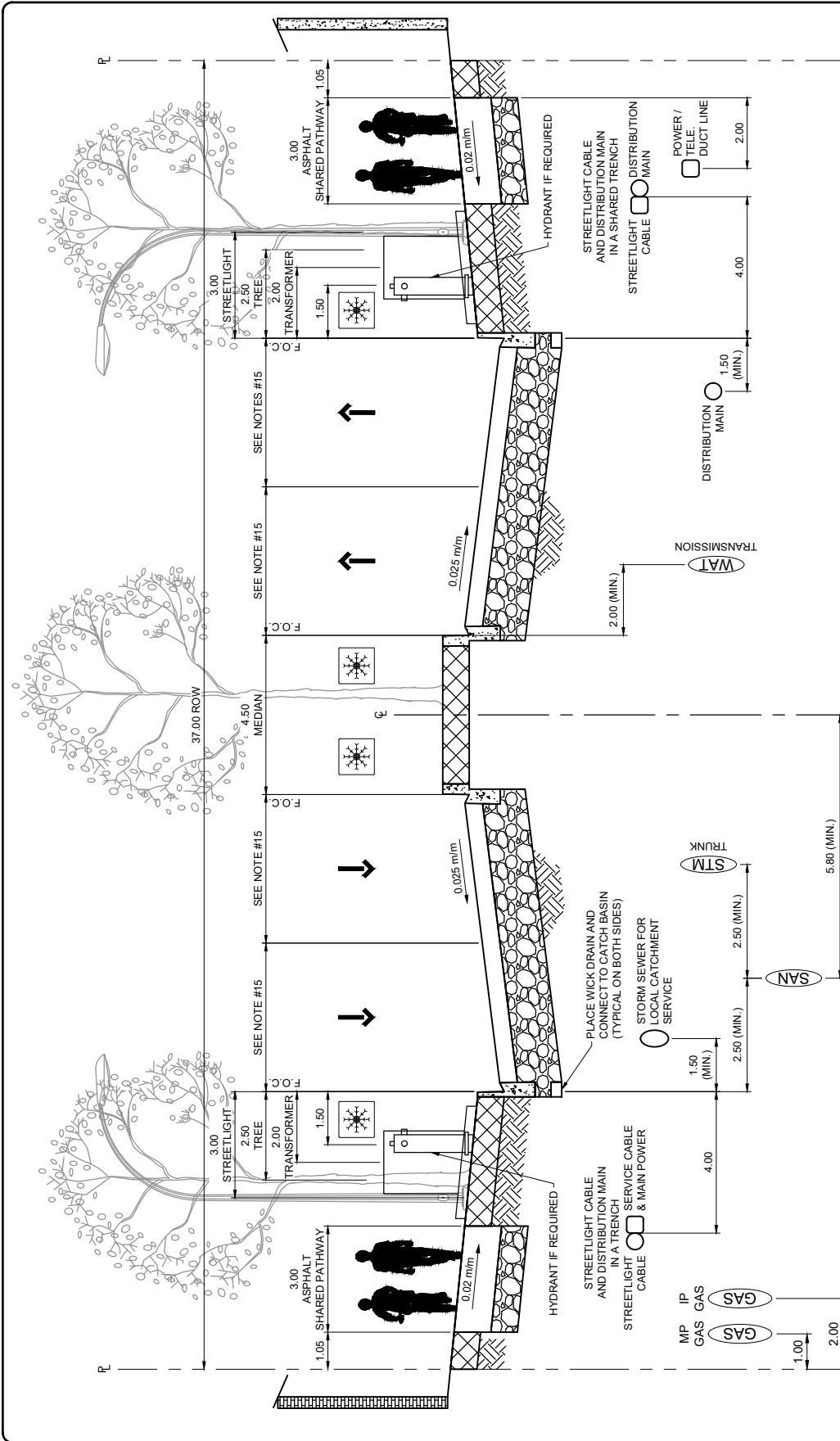

NOTE:

1. UTILITY OFFSETS FROM ROADWAY INFRASTRUCTURE AND BETWEEN UTILITIES TO BE PROVIDED AS PER VOLUME 1.
2. FRONT DRIVEWAYS ARE NOT PERMITTED.
3. WATER TO BE ON OPPOSITE SIDE OF MAIN POWER LINE.
4. PIPE SIZES AND DEPTHS MAY VARY.
5. LANDSCAPING MUST NOT COVER POLE BASE.
6. DEPTH OF MAIN POWER, TELEPHONES AND CABLE T.V. TRENCH TO BE MINIMUM 1.10m.
7. DEPTH OF GAS TRENCH TO BE MINIMUM 1.10m WITHIN ROAD ROW.
8. CROSS FALLS ARE MEASURED FROM LIP OF GUTTER.
9. MAXIMUM SIDESLOPE FROM SHARED PATHWAY TO PROPERTY LINE IS 3.5:1.
10. MAXIMUM SIDESLOPE FROM BACK OF CURB TO SHARED PATHWAY IS 10.00%.
11. SURFACE DRAINAGE TO CONFORM TO THE DRAINAGE BYLAW.
12. STREETLIGHT CABLE CAN BE INSTALLED AT THE SAME ALIGNMENT AS POWER AND COMMUNICATIONS.
13. LANE WIDTHS BASED ON CONTEXT. REFER TO SECTION 3.2.2.3.
14. NOISE ATTENUATION FENCE AS PER DETAIL #5205 ALONG ALL RESIDENTIAL PROPERTY LINES. NOISE BERMS TO BE PROVIDED PER DETAIL #2000 FOR ALL TRUCK ROUTES OR WHERE REQUIRED BASED ON NOISE STUDY.
15. REFER TO VOLUME 5 (LANDSCAPING) FOR DETAILS ON MEDIAN LANDSCAPE TREATMENTS.

LEGEND:

- SNOW STORAGE AREA
- DRIVING LANE

ALL DIMENSIONS IN METRES UNLESS OTHERWISE NOTED

STANDARD DRAWING

FOUR LANE DIVIDED ARTERIAL - 37.00m ROW

DATE APPROVED: 2025	DRAWN BY: FR	APPROVED: 	DRAWING NUMBER: 2510
SCALE: N.T.S.	CHECKED BY: JN		

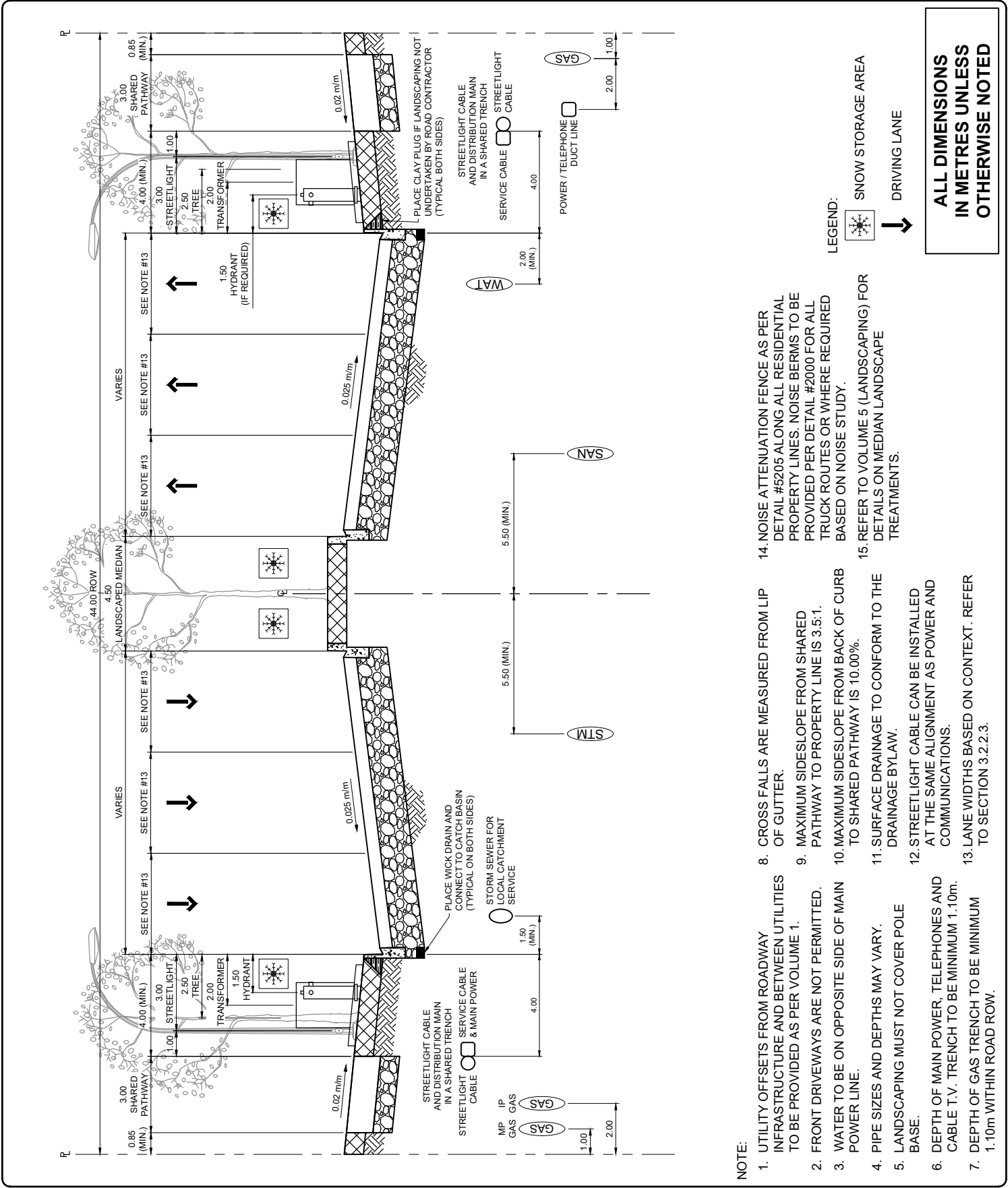

- NOTE:**
- UTILITY OFFSETS FROM ROADWAY INFRASTRUCTURE AND BETWEEN UTILITIES TO BE PROVIDED AS PER VOLUME 1.
 - FRONT DRIVEWAYS ARE NOT PERMITTED.
 - WATER TO BE ON OPPOSITE SIDE OF MAIN POWER LINE.
 - PIPE SIZES AND DEPTHS MAY VARY.
 - LANDSCAPING MUST NOT COVER POLE BASE.
 - DEPTH OF MAIN POWER, TELEPHONES AND CABLE T.V. TRENCH TO BE MINIMUM 1.10m.
 - DEPTH OF GAS TRENCH TO BE MINIMUM 1.10m WITHIN ROAD ROW.
 - CROSS FALLS ARE MEASURED FROM LIP OF GUTTER.
 - MAXIMUM SIDESLOPE FROM SHARED PATHWAY TO PROPERTY LINE IS 3.5:1.
 - MAXIMUM SIDESLOPE FROM BACK OF CURB TO SHARED PATHWAY IS 10.00%.
 - SURFACE DRAINAGE TO CONFORM TO THE DRAINAGE BYLAW.
 - STREETLIGHT CABLE CAN BE INSTALLED AT THE SAME ALIGNMENT AS POWER AND COMMUNICATIONS.
 - LANE WIDTHS BASED ON CONTEXT. REFER TO SECTION 3.2.2.3.
 - NOISE ATTENUATION FENCE AS PER DETAIL #5205 ALONG ALL RESIDENTIAL PROPERTY LINES. NOISE BERMS TO BE PROVIDED PER DETAIL #2000 FOR ALL TRUCK ROUTES OR WHERE REQUIRED BASED ON NOISE STUDY.
 - REFER TO VOLUME 5 (LANDSCAPING) FOR DETAILS ON MEDIAN LANDSCAPE TREATMENTS.

LEGEND:

- SNOW STORAGE AREA
- DRIVING LANE

ALL DIMENSIONS IN METRES UNLESS OTHERWISE NOTED

STANDARD DRAWING

SIX LANE URBAN DIVIDED ARTERIAL - 44.00m ROW

DATE APPROVED: 2025	DRAWN BY: FR	APPROVED: 	DRAWING NUMBER: 2520
SCALE: N.T.S.	CHECKED BY: JN		

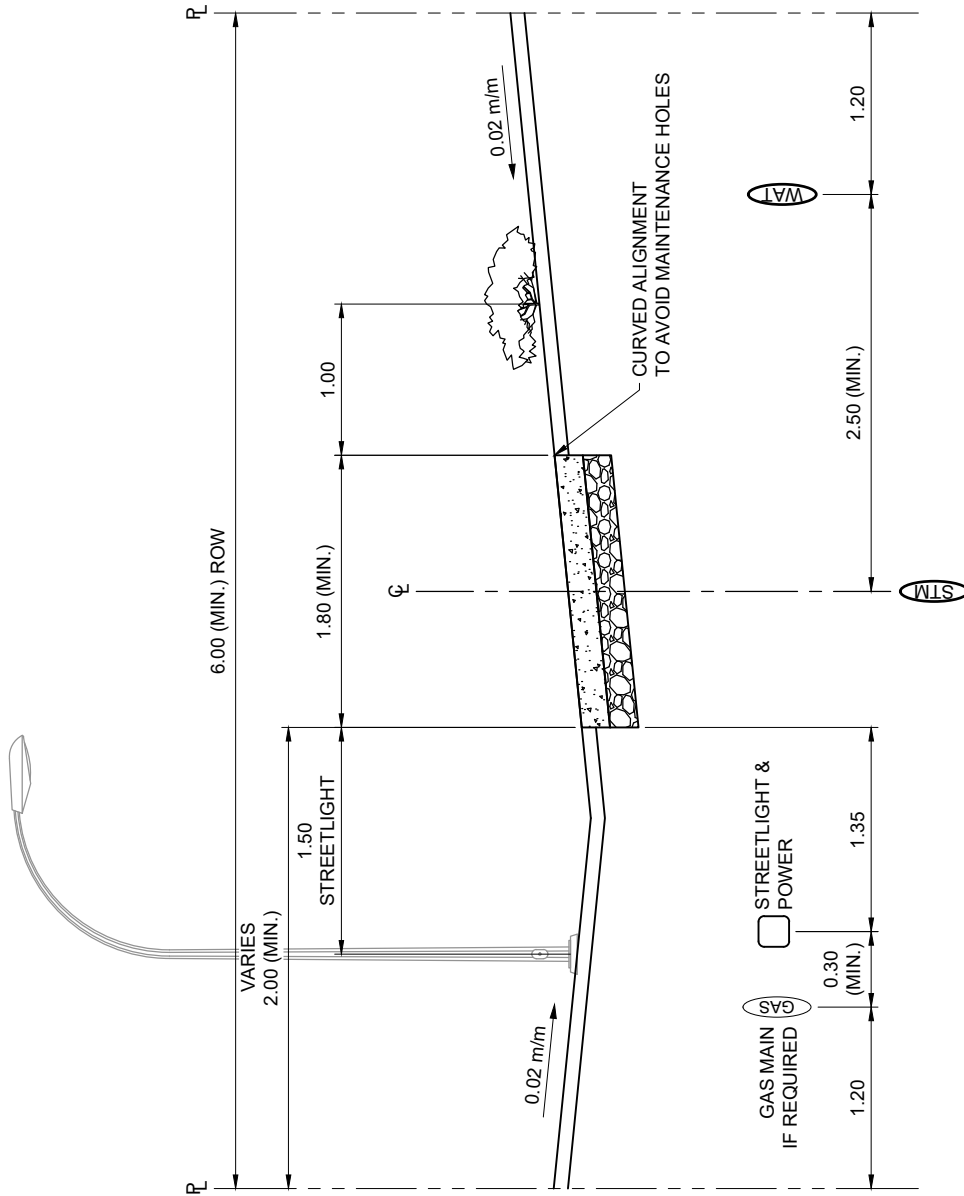

STORM SEWER IF REQUIRED
NOTE: NO MAINTENANCE HOLE IN WALK

NOTE:

1. MAJOR WALK LOCATION VARIES IN ROW.
2. MINOR WALK LOCATION GENERALLY ON CENTRELINE.
3. LANDSCAPING MUST NOT COVER POLE BASES.
4. DEPTH OF POWER TRENCH TO BE MINIMUM 1.10m.
5. DEPTH OF GAS TRENCH TO BE MINIMUM 1.10m.
6. VERTICAL SEPARATION BETWEEN POWER AND GAS TO BE MINIMUM 0.30m.
7. HORIZONTAL SEPARATION BETWEEN STORM SEWER AND POWER TO BE MINIMUM 3.00m.
8. REFER TO LANDSCAPE STANDARDS FOR TREE LOCATION AND LANDSCAPE TREATMENTS.
9. SWALE TO BE MINIMUM 0.60m.
10. STREETLIGHT CABLE CAN BE INSTALLED AT THE SAME ALIGNMENT AS POWER AND COMMUNICATIONS.

**ALL DIMENSIONS
IN METRES UNLESS
OTHERWISE NOTED**



STANDARD DRAWING

UTILITIES LOCATION PLAN WALKWAYS - 6.0m ROW

DATE APPROVED: **2025**

DRAWN BY: **FR**

APPROVED:

DRAWING NUMBER: **2600**

SCALE: **N.T.S.**

CHECKED BY: **JN**

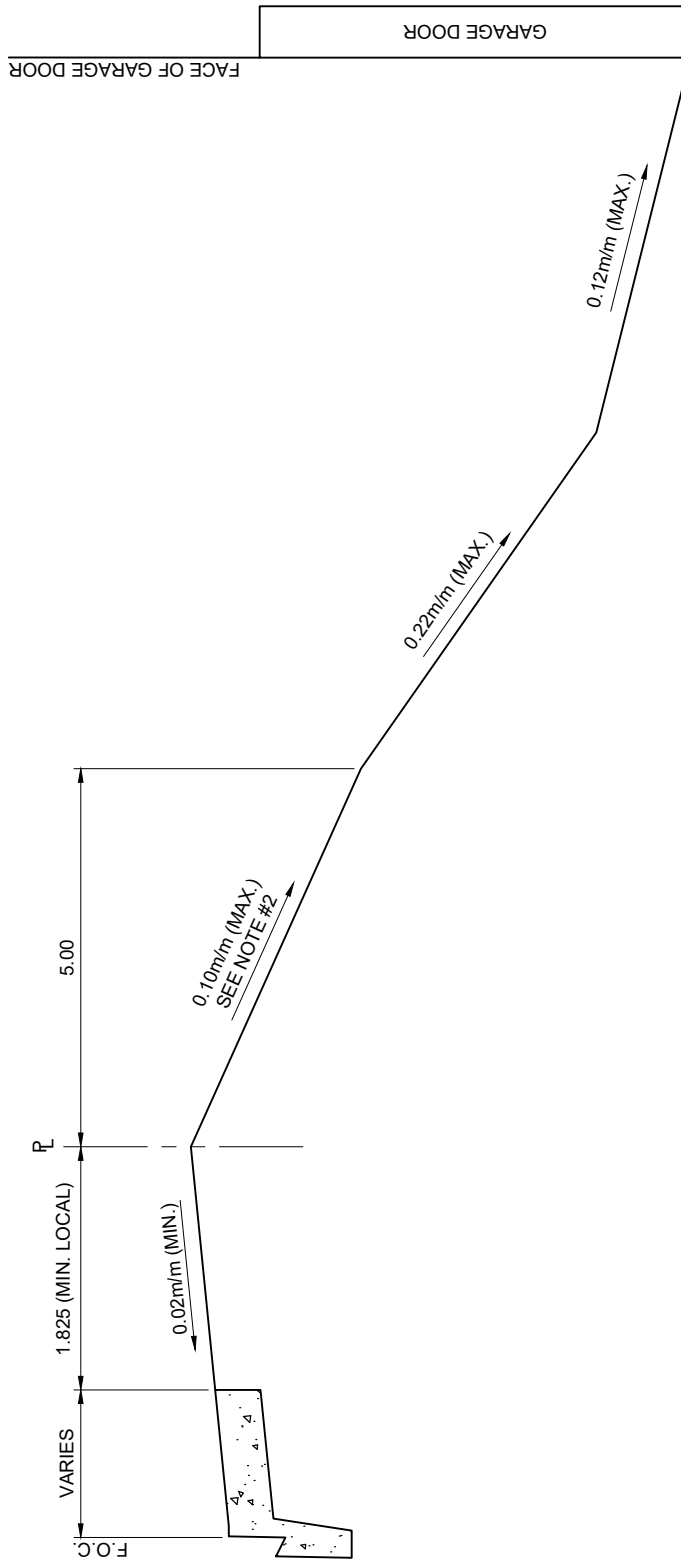

**ALL DIMENSIONS
IN METRES UNLESS
OTHERWISE NOTED**

NOTE:

1. THE RECOMMENDED MAXIMUM SLOPE OF 2.00% SHALL BE PROVIDED WITHIN ROAD RIGHT-OF-WAY FROM THE PROPERTY LINE TO THE BACK OF THE MONOWALK.
2. THE BELOW GRADE DRIVEWAY SLOPE / PARKADE RAMP MUST NOT EXCEED 10.00% FOR A MINIMUM DISTANCE OF 5.00m FROM THE PROPERTY LINE INTO THE SITE.
3. THE BELOW GRADE DRIVEWAY SLOPE / PARKADE RAMP MUST BE AT GRADE AT THE PROPERTY LINE.
4. NO PORTION OF THE BELOW GRADE DRIVEWAY SLOPE / PARKADE RAMP OR RETAINING WALL / GUARD RAILS WILL BE PERMITTED WITHIN ROAD RIGHT-OF-WAY.
5. PROPOSED RETAINING WALLS BORDERING THE BELOW GRADE DRIVEWAY SLOPE / PARKADE RAMP MUST NOT EXCEED A HEIGHT OF 0.30m FOR A DISTANCE OF 3.00m INTO THE SITE.
6. PROPOSED GUARD RAILS LOCATED ON RETAINING WALLS MUST NOT OBSTRUCT SIGHT LINES FOR EXITING VEHICLES.
7. MORE THAN A 12.00% DIFFERENCE IN THE BELOW GRADE DRIVEWAY SLOPE / PARKADE RAMP WITHIN PRIVATE PROPERTY MAY RESULT IN VEHICLES "BOTTOMING OUT" AT THE BREAK-OVER POINT.
8. ANY MODIFICATION TO THIS GUIDELINE OR DRAWING WILL REQUIRE THE REVIEW AND APPROVAL OF CITY OF EDMONTON.



STANDARD DRAWING

**SLOPE REGULATION
RESIDENTIAL PRIVATE DRIVEWAY / PARKADE RAMP
MONOWALK**

DATE APPROVED: **2025**

DRAWN BY: **FR**

APPROVED: *[Signature]*

DRAWING NUMBER: **2720**

SCALE: **N.T.S.**

CHECKED BY: **JN**

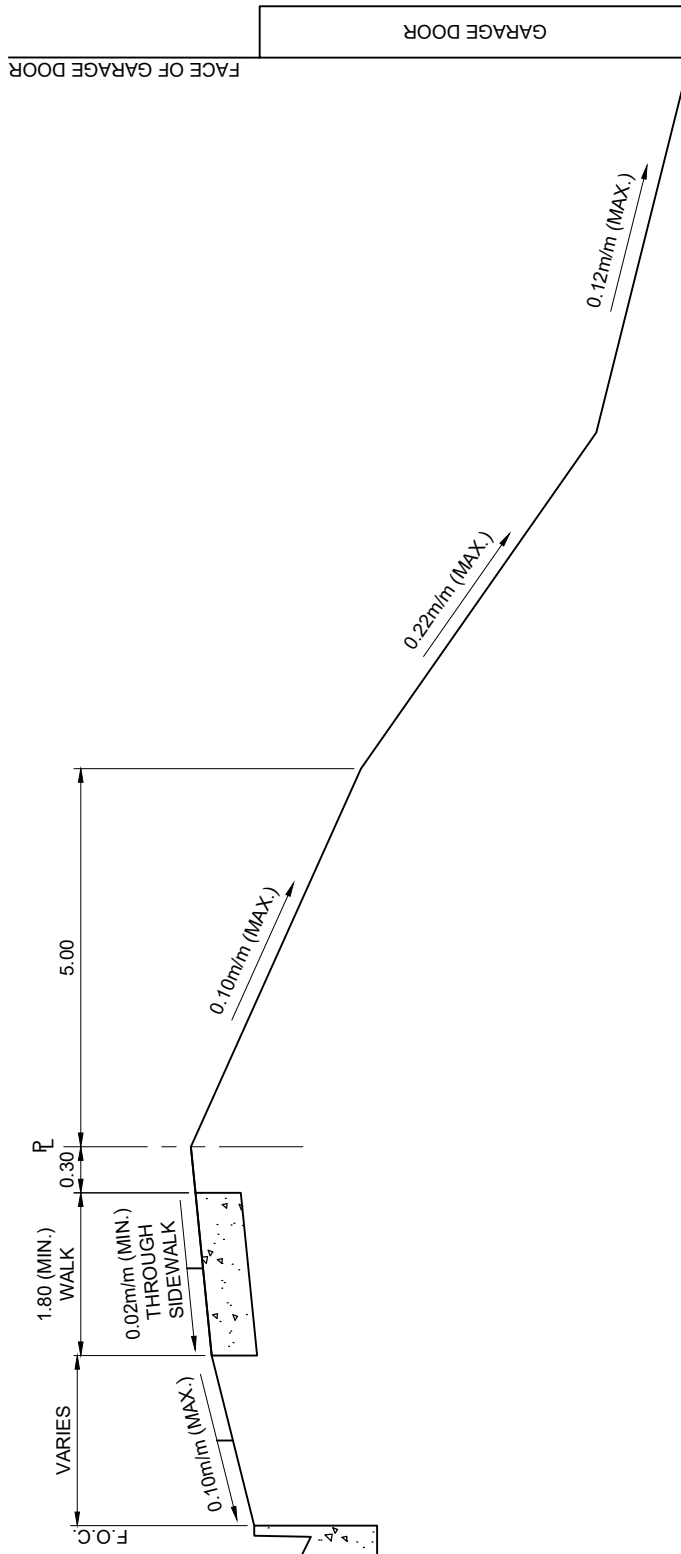

**ALL DIMENSIONS
IN METRES UNLESS
OTHERWISE NOTED**

NOTE:

1. THE RECOMMENDED MAXIMUM SLOPE OF 2.00% SHALL BE PROVIDED WITHIN ROAD RIGHT-OF-WAY FROM THE PROPERTY LINE TO THE BACK OF THE MONOWALK.
2. THE BELOW GRADE DRIVEWAY SLOPE / PARKADE RAMP MUST NOT EXCEED 10.00% FOR A MINIMUM DISTANCE OF 5.00m FROM THE PROPERTY LINE INTO THE SITE.
3. THE BELOW GRADE DRIVEWAY SLOPE / PARKADE RAMP MUST BE AT GRADE AT THE PROPERTY LINE.
4. NO PORTION OF THE BELOW GRADE DRIVEWAY SLOPE / PARKADE RAMP OR RETAINING WALL / GUARD RAILS WILL BE PERMITTED WITHIN ROAD RIGHT-OF-WAY.
5. PROPOSED RETAINING WALLS BORDERING THE BELOW GRADE DRIVEWAY SLOPE / PARKADE RAMP MUST NOT EXCEED A HEIGHT OF 0.30m FOR A DISTANCE OF 3.00m INTO THE SITE.
6. PROPOSED GUARD RAILS LOCATED ON RETAINING WALLS MUST NOT OBSTRUCT SIGHT LINES FOR EXITING VEHICLES.
7. MORE THAN A 12.00% DIFFERENCE IN THE BELOW GRADE DRIVEWAY SLOPE / PARKADE RAMP WITHIN PRIVATE PROPERTY MAY RESULT IN VEHICLES "BOTTOMING OUT" AT THE BREAK-OVER POINT.
8. ANY MODIFICATION TO THIS GUIDELINE OR DRAWING WILL REQUIRE THE REVIEW AND APPROVAL OF CITY OF EDMONTON.



STANDARD DRAWING

**SLOPE REGULATIONS
RESIDENTIAL PRIVATE DRIVEWAY / PARKADE RAMP
BOULEVARD WALK**

DATE APPROVED: **2025**

SCALE: **N.T.S.**

DRAWN BY: **FR**

CHECKED BY: **JN**

APPROVED: 

DRAWING NUMBER: **2730**

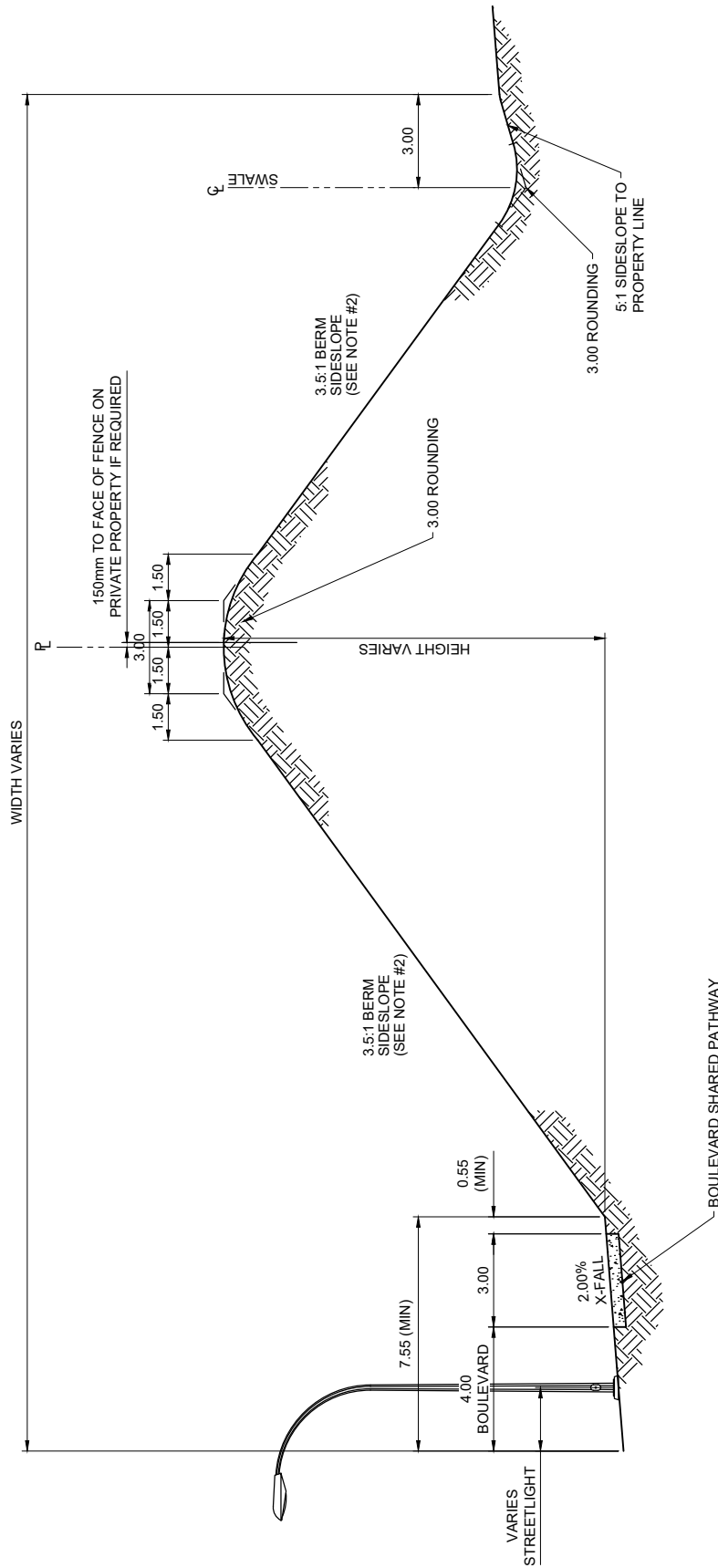

**ALL DIMENSIONS
IN METRES UNLESS
OTHERWISE NOTED**

- NOTE:
1. THE ABOVE DIAGRAM INDICATES THE DESIRABLE BERM FORMAT FOR MAXIMUM HEIGHT OF BERM
 2. BERM SIDESLOPE MAXIMUM IS 3:1, SUBJECT TO APPROVAL BY CITY OF EDMONTON
 3. PROPERTY LINE SWALE IS SUBJECT TO LOT GRADING DESIGN
 4. BERM HEIGHT SHALL BE MEASURED FROM TOE OF SLOPE ON ROADWAY SIDE

TYPICAL BERM SECTION



STANDARD DRAWING

DATE APPROVED: **2025**

SCALE: **N.T.S.**

DRAWN BY: **FR**

CHECKED BY: **JN**

APPROVED: *[Signature]*

DRAWING NUMBER: **2000**



Standard Drawings

SECTION 3000 – DESIGN DETAILS

NOTES:

1. ILLUSTRATION BASED ON MINIMUM TURNING REQUIREMENTS OF WB-21 DESIGN VEHICLE.

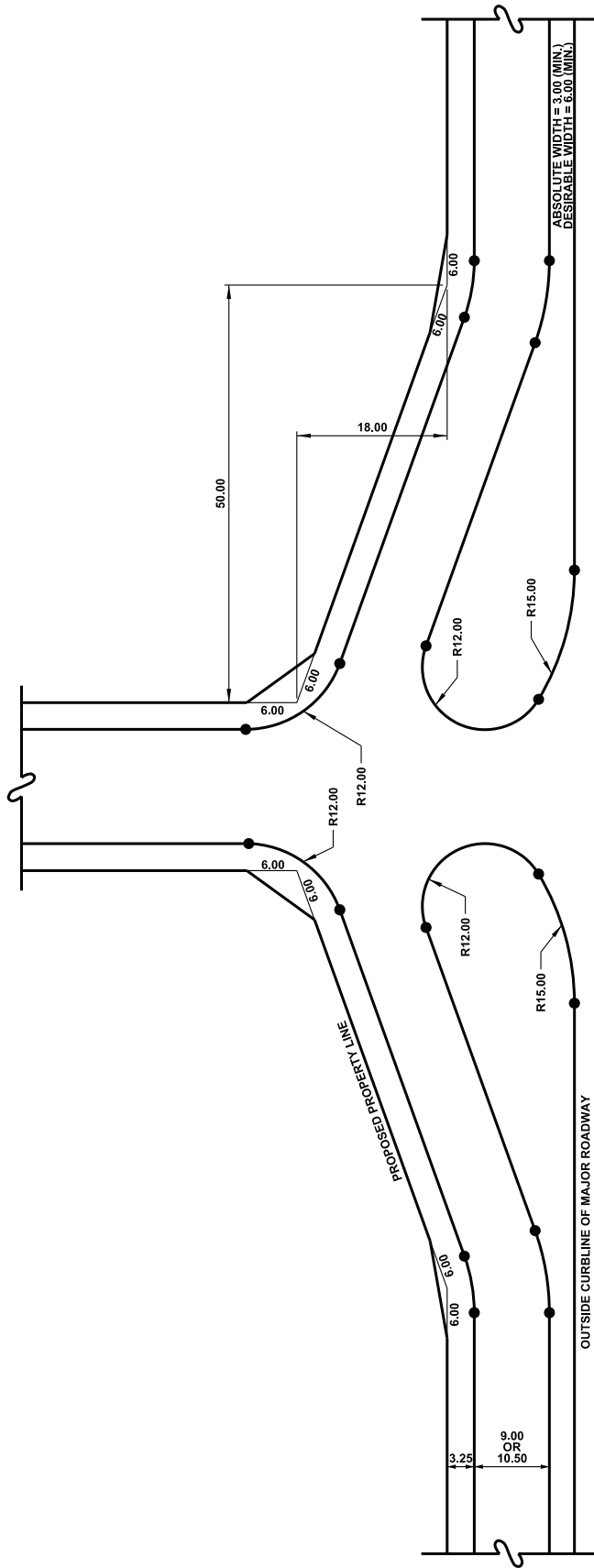

ALL DIMENSIONS
IN METRES UNLESS
OTHERWISE NOTED



INDUSTRIAL SERVICE ROAD
"BULB" ENTRANCE

DATE APPROVED: 2018
SCALE: N.T.S.

DRAWN BY: KSYC
CHECKED BY: JN

APPROVED: *M.A.R.*

DRAWING NUMBER: 3000

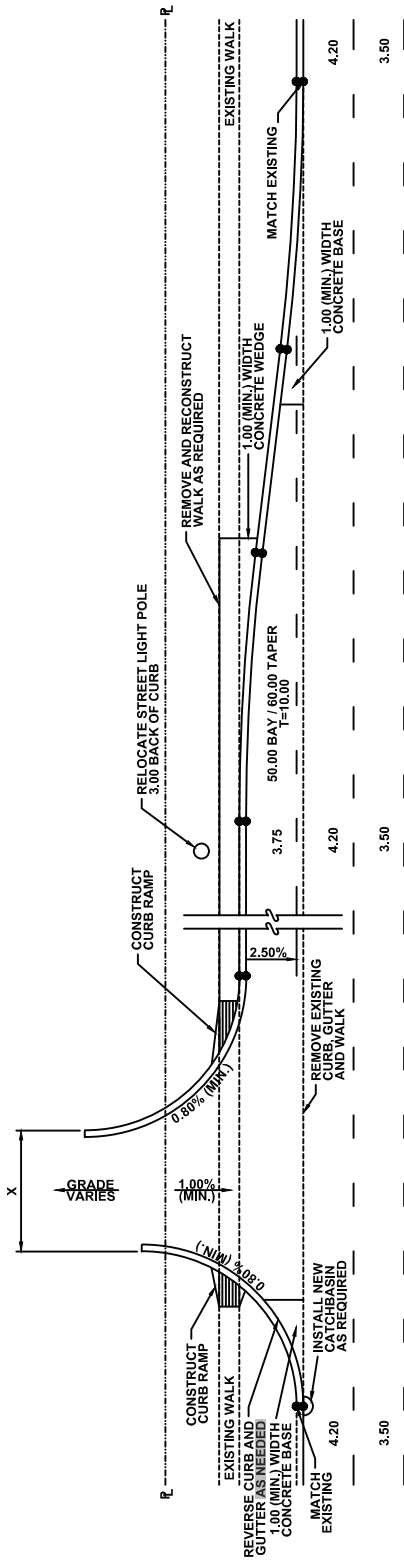

ALTERNATE A: RIGHT TURN BAY REQUIRED

DEFAULT PAVEMENT STRUCTURE:
 - 75.00mm ASPHALT
 - 150.00mm CONCRETE
 - 150.00mm PLANT-MIX SOIL CEMENT
 - 150.00mm SUBGRADE PREPARATION

X = 7.50 (MIN.) WIDTH - TWO WAY OPERATION
 = 5.00 (MIN.) WIDTH - ONE WAY OPERATION
 R = 6.00 (MIN.) - VARIES

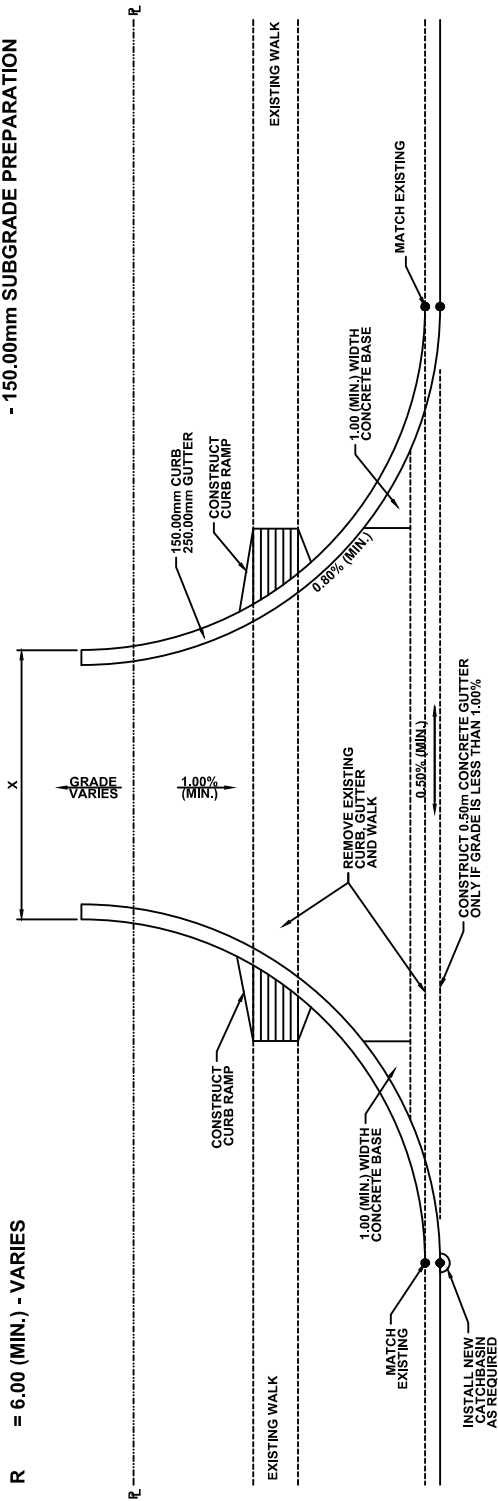

ALTERNATE B: NO RIGHT TURN BAY REQUIRED

NOTES:

1. IF CONSTRUCTION IS TO BE UNDERTAKEN BY PRIVATE DEVELOPER, THEN SERVICING AGREEMENT IS REQUIRED. CONTACT DEVELOPMENT SERVICING AGREEMENTS.
2. ALL WORK TO CONFORM TO CITY OF EDMONTON SPECIFICATIONS.
3. RE-LANDSCAPE AS REQUIRED WITH SOD.
4. ALL DIMENSIONS ARE TO LIP OF GUTTER.
5. PAVEMENT STRUCTURE TO BE CONFIRMED IN FIELD BY ENGINEER.
6. LANE WIDTHS BASED ON CONTEXT, REFER TO SECTION 3.2.2.3.
7. CURB RETURN RADIUS TO ACCOMMODATE APPROPRIATE DESIGN VEHICLE BASED ON SITE USAGE.

ALL DIMENSIONS
 IN METRES UNLESS
 OTHERWISE NOTED

MAJOR COMMERCIAL ACCESS
 TYPICAL CURB RETURN FORMAT



STANDARD DRAWING

DATE APPROVED: **2018**
 SCALE: **N.T.S.**

DRAWN BY: **KSYC**
 CHECKED BY: **JN**

APPROVED: *M.A.R.*

DRAWING NUMBER: **3010**

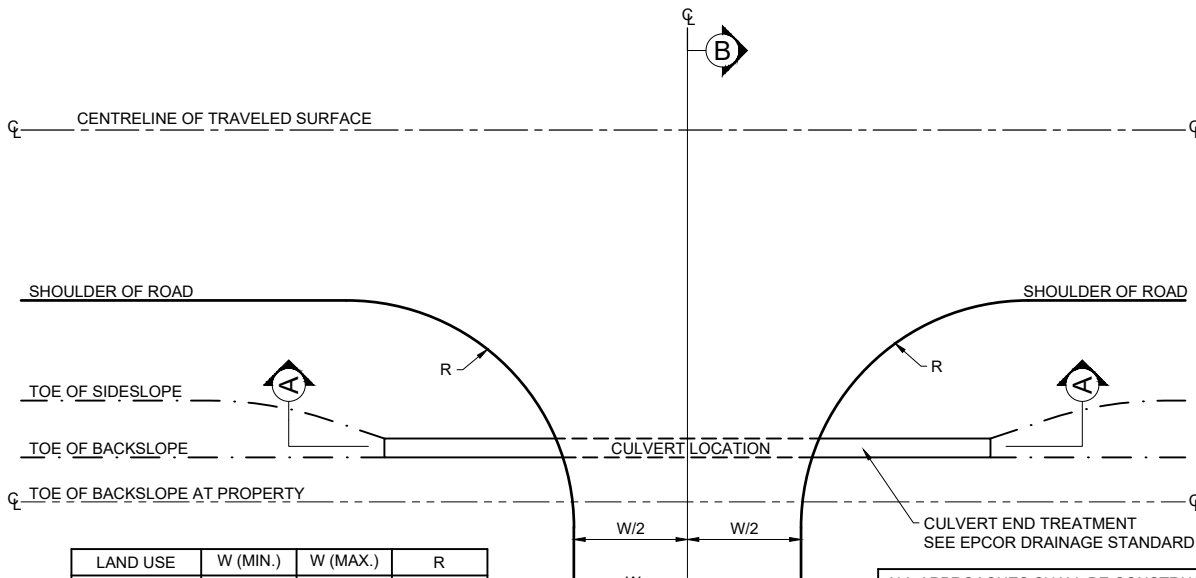

LAND USE	W (MIN.)	W (MAX.)	R
RESIDENTIAL:			
SINGLE	6.00	7.50	10.00
MULTIPLE	10.00	11.00	10.00
FIELD	8.00	15.00	10.00
COMMERCIAL	8.00	15.00	10.00
INDUSTRIAL	8.00	21.00	15.00

ALL APPROACHES SHALL BE CONSTRUCTED TO THE SAME PAVEMENT STRUCTURE AS THE ADJOINING ROADWAYS, OR THE FOLLOWING MINIMUMS, WHICHEVER IS GREATER:

MINIMUM COMMERCIAL / INDUSTRIAL PAVEMENT STRUCTURE

- 150mm ASPHALT (50mm 10mm-HT OVER 100MM 20MM-B)
- 200mm GRAVEL
- MIN. 150mm SUBGRADE PREPARATION (OR APPROVED ALTERNATIVE BY COE FIELD REPRESENTATIVE)

MINIMUM RESIDENTIAL PAVEMENT STRUCTURE:

- 100mm ASPHALT
- 200mm GRAVEL
- MIN 150mm SUBGRADE PREPARATION (OR APPROVED ALTERNATIVE BY COE FIELD REPRESENTATIVE)

FOR ROADWAYS WITH ASPHALT SURFACING, THE APPROACHES WILL EXTEND TO THE FOLLOWING LIMITS:

- INDUSTRIAL, COMMERCIAL, AND RESIDENTIAL: TO THE PROPERTY LINE; AND
- FIELD APPROACHES: 3.5m FROM EDGE OF SURFACED SHOULDER

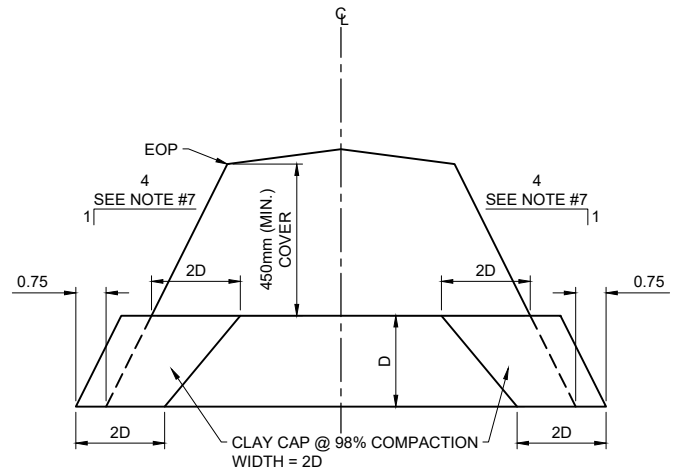
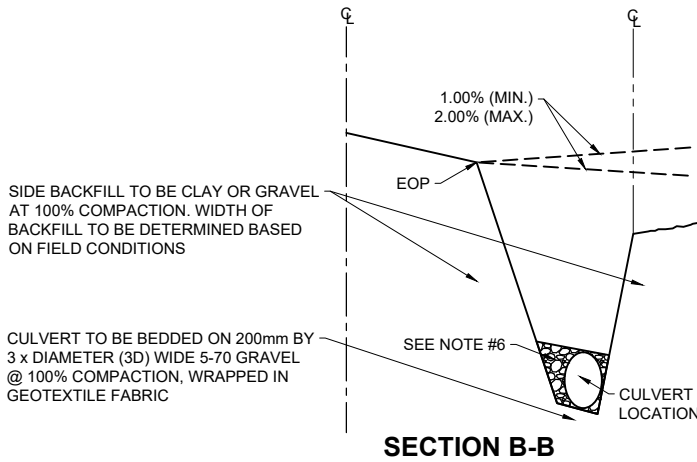

NOTE:

1. CULVERT MINIMUM DIAMETER 450mm C.M.P.
2. COVER DEPTH MINIMUM 450mm.
3. CULVERT TO EXTEND 0.75m BEYOND TOE OF FILL.
4. CROSSING PERMIT REQUIRED FOR ACCESS CONSTRUCTION.
5. CULVERT CONSTRUCTION TO COMPLY WITH DRAINAGE SPECIFICATION 19 CORRUGATED STEEL PIPE CULVERT.
6. SEE SPECIFICATIONS FOR COMPACTION AND BEDDING REQUIREMENTS.
7. SIDESLOPE DEPENDS ON DESIGN SPEED AND TRAFFIC VOLUME, REFER TO TAC GUIDELINES.
8. RIP RAP REQUIREMENTS SEE CONSTRUCTION SPECIFICATION - 8.2 HEAVY ROCK RIP RAP AND DRAINAGE STANDARD DRAWING DR-06-19-01.

ALL DIMENSIONS IN METRES UNLESS OTHERWISE NOTED

Edmonton
STANDARD DRAWING

RURAL LOCAL ACCESS

DATE APPROVED: **2025**
SCALE: **N.T.S.**

DRAWN BY: **FR**
CHECKED BY: **JN**

APPROVED: *[Signature]*

DRAWING NUMBER: **3020**

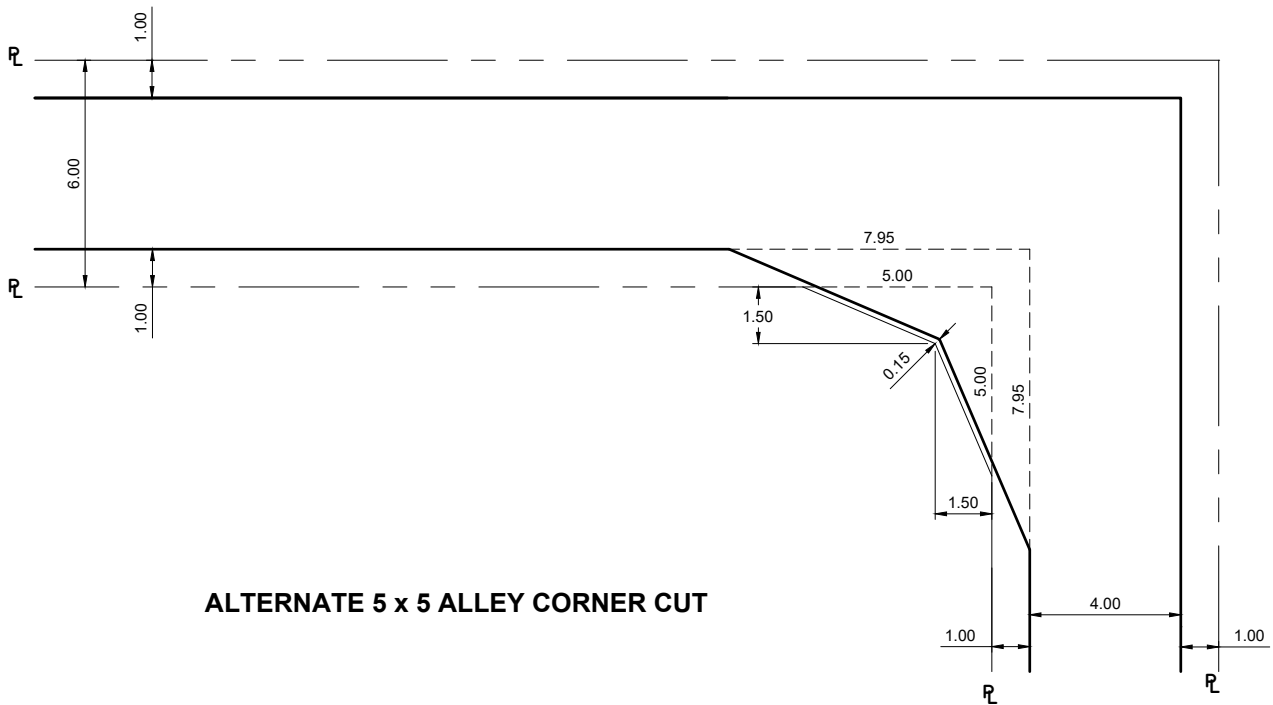
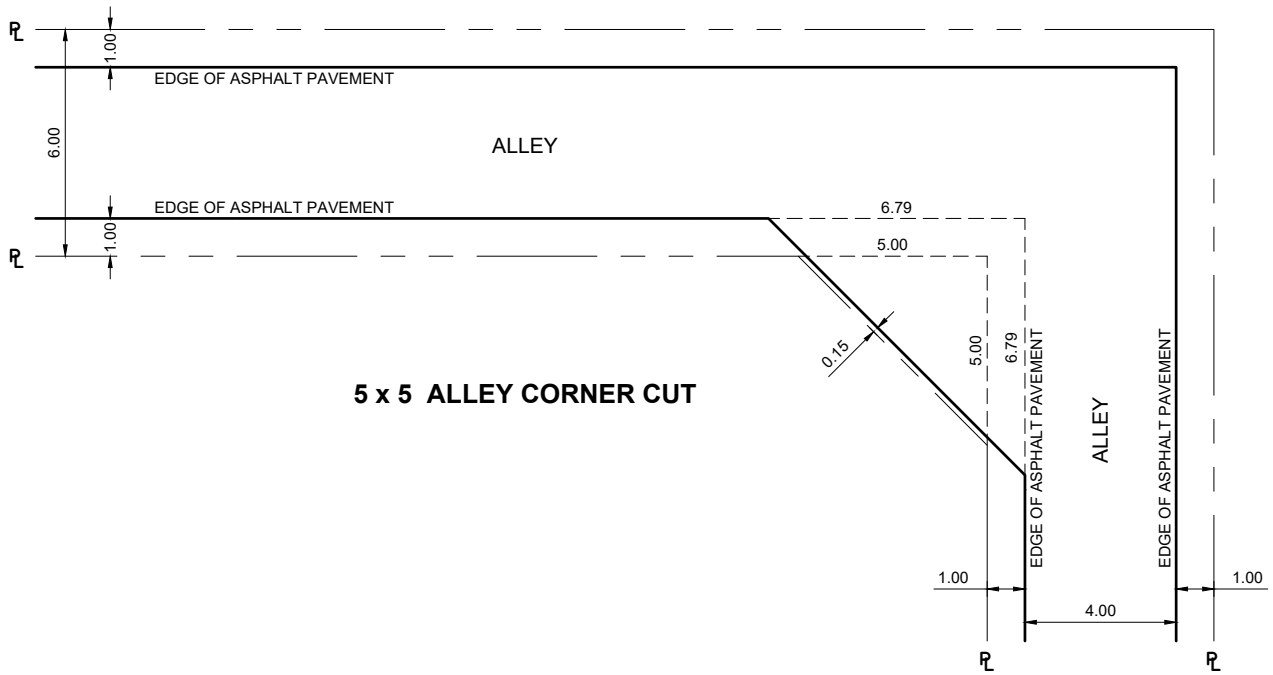

NOTE:

1. DESIGN VEHICLE BASED ON FRONT LOADING GARBAGE TRUCK.
2. CONFIGURATION TO BE SELECTED BASED ON CONTEXT.

**ALL DIMENSIONS
IN METRES UNLESS
OTHERWISE NOTED**

ALLEY CORNER CUT (5.00m X 5.00m)



STANDARD DRAWING

DATE APPROVED: **2025**

DRAWN BY: **FR**

APPROVED: *[Signature]*

DRAWING NUMBER: **3031**

SCALE: **N.T.S.**

CHECKED BY: **JN**

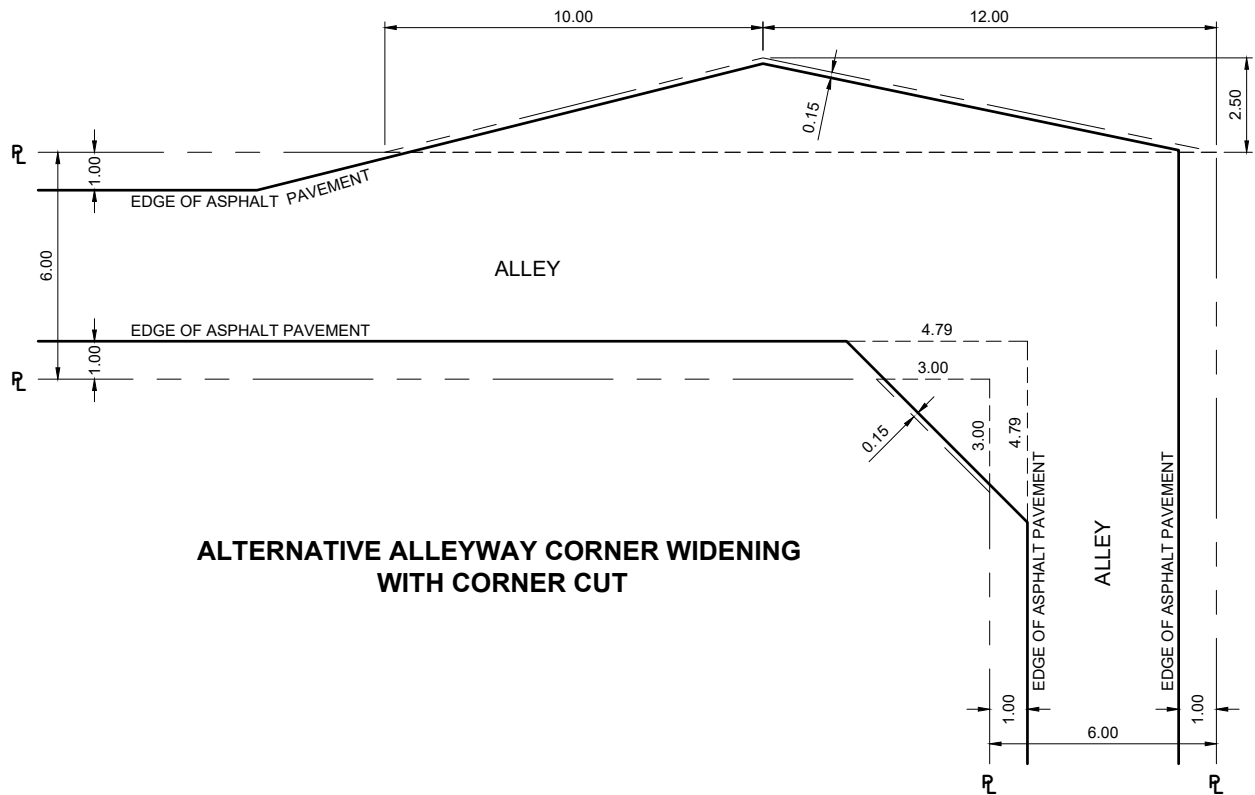

ALTERNATIVE ALLEYWAY CORNER WIDENING WITH CORNER CUT

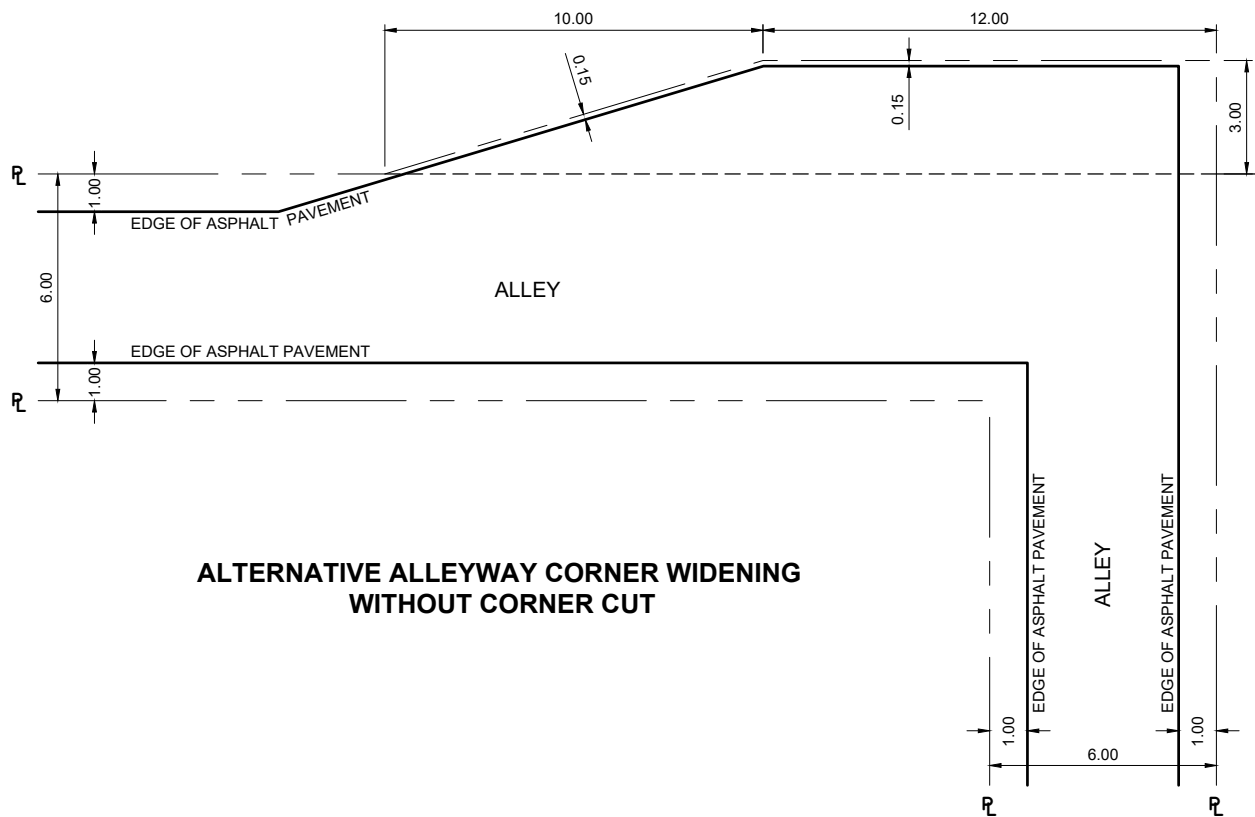

ALTERNATIVE ALLEYWAY CORNER WIDENING WITHOUT CORNER CUT

NOTE:

1. DESIGN VEHICLE BASED ON FRONT LOADING GARBAGE TRUCK.
2. CONFIGURATION TO BE SELECTED BASED ON CONTEXT

ALL DIMENSIONS IN METRES UNLESS OTHERWISE NOTED

STANDARD DRAWING

ALTERNATIVE ALLEY CORNER WIDENING IN LIEU OF 5.00 x 5.00 CORNER CUT

DATE APPROVED: **2025**
SCALE: **N.T.S.**

DRAWN BY: **FR**
CHECKED BY: **JN**

APPROVED: *[Signature]*

DRAWING NUMBER: **3032**

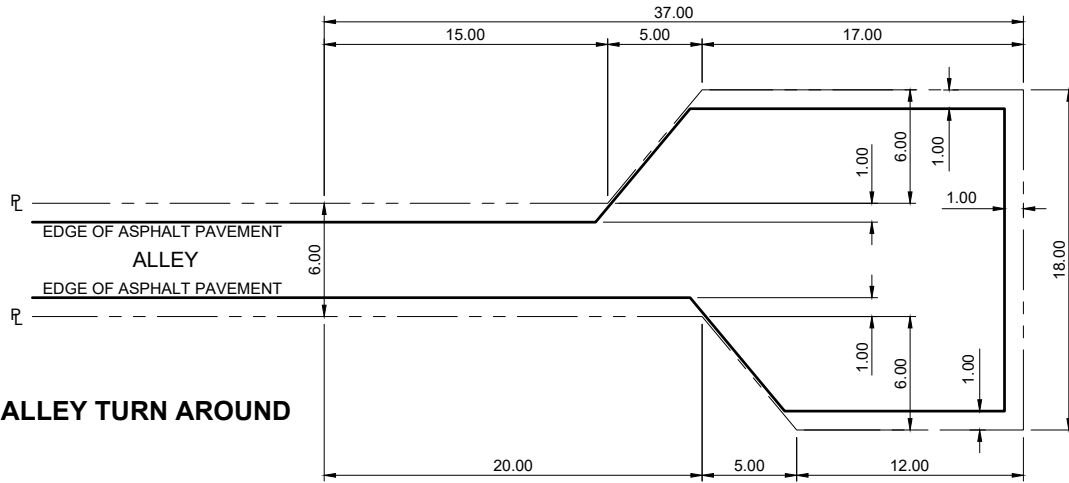

STANDARD ALLEY TURN AROUND

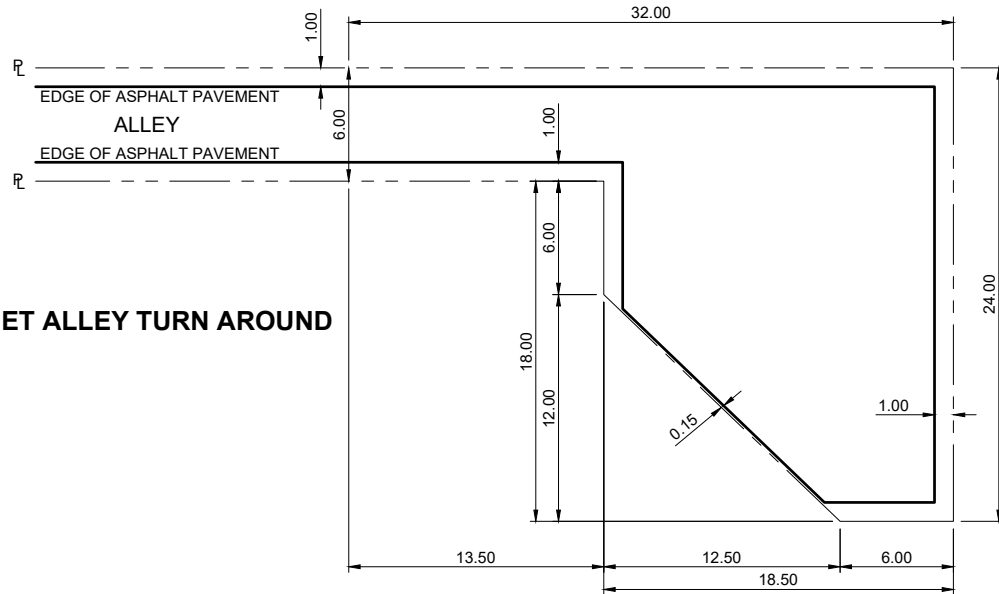

STANDARD OFFSET ALLEY TURN AROUND

NOTE:

1. DESIGN VEHICLE BASED ON CITY OF EDMONTON WASTER COLLECTION VEHICLE.
2. CONFIGURATION TO BE SELECTED BASED ON CONTEXT.

**ALL DIMENSIONS
IN METRES UNLESS
OTHERWISE NOTED**

STANDARD DRAWING

PUBLIC ALLEY TURN AROUND

DATE APPROVED: **2025**
SCALE: **N.T.S.**

DRAWN BY: **FR**
CHECKED BY: **JN**

APPROVED: *[Signature]*

DRAWING NUMBER: **3040**

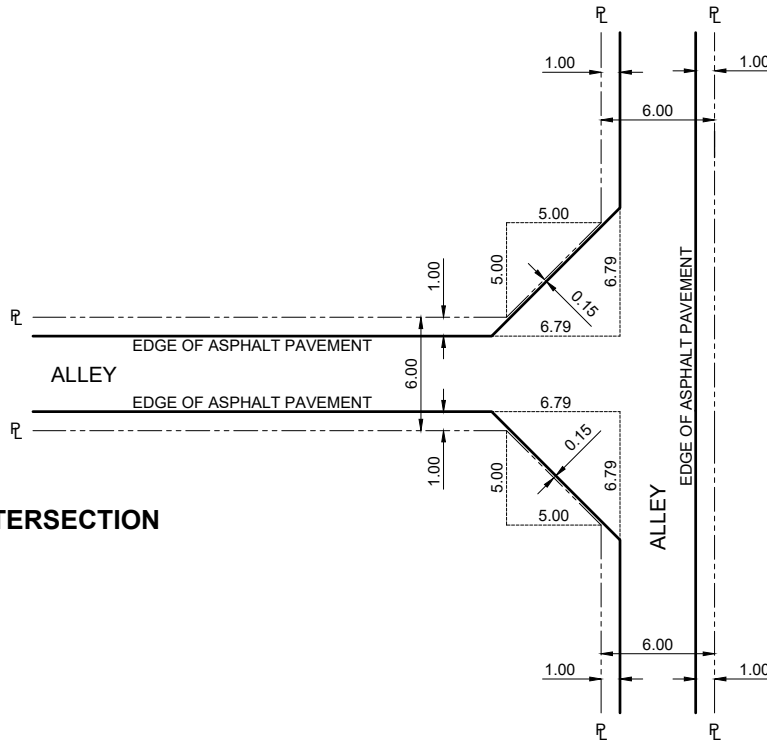

5 x 5 ALLEY INTERSECTION

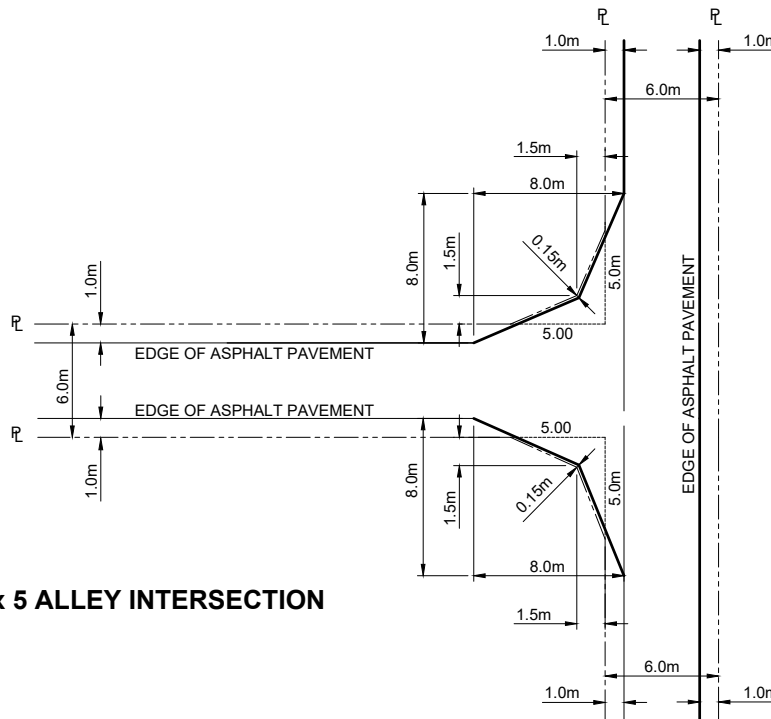

ALTERNATE 5 x 5 ALLEY INTERSECTION

NOTE:

1. DESIGN VEHICLE BASED ON CITY OF EDMONTON WASTE COLLECTION VEHICLE.
2. CONFIGURATION TO BE SELECTED BASED ON CONTEXT.

**ALL DIMENSIONS
IN METRES UNLESS
OTHERWISE NOTED**



STANDARD DRAWING

PUBLIC ALLEY INTERSECTION

DATE APPROVED: **2025**
SCALE: **N.T.S.**

DRAWN BY: **FR**
CHECKED BY: **JN**

APPROVED: 

DRAWING NUMBER: **3041**

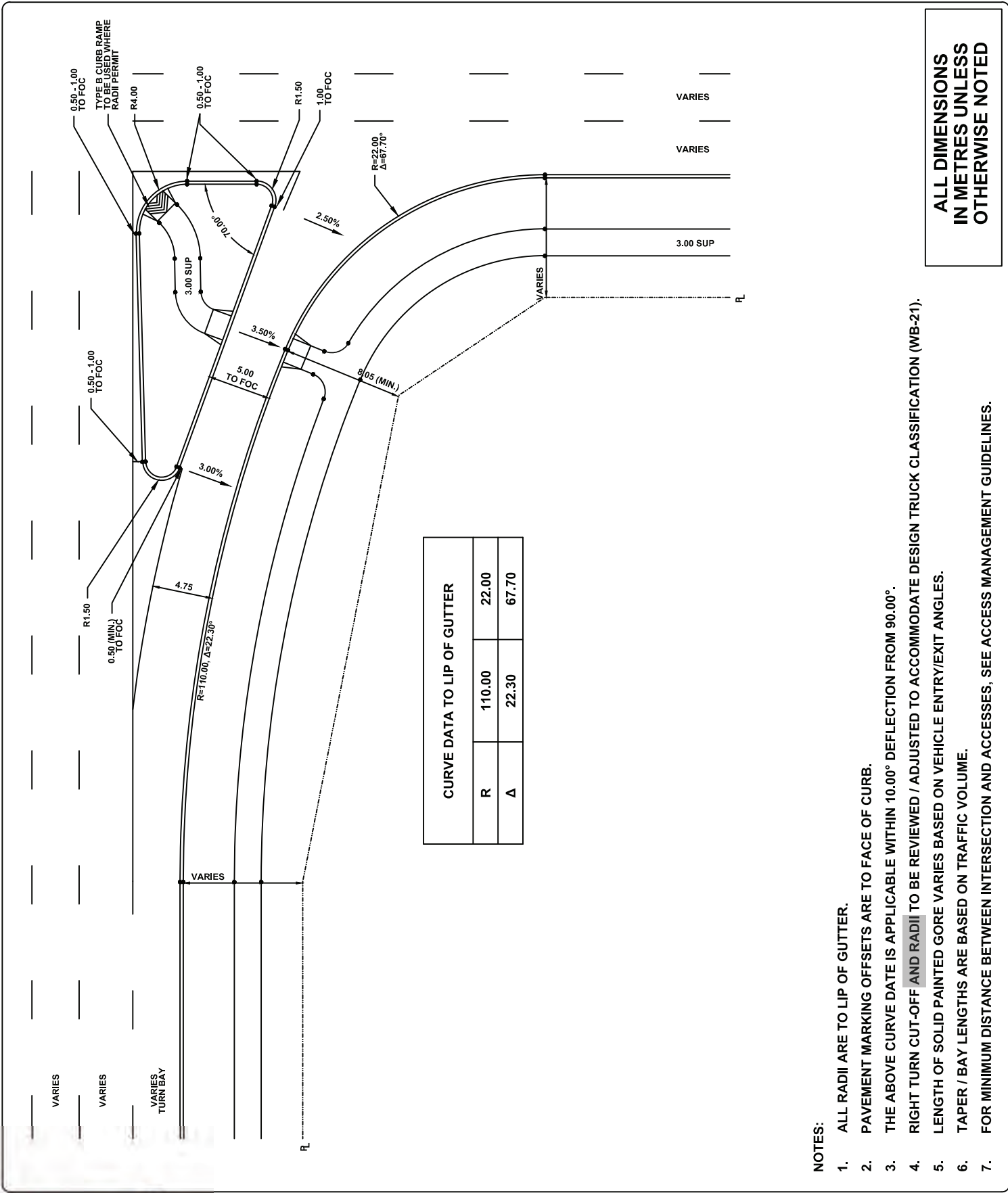

**ALL DIMENSIONS
IN METRES UNLESS
OTHERWISE NOTED**

R	110.00	22.00
Δ	22.30	67.70

- NOTES:
1. ALL RADII ARE TO LIP OF GUTTER.
 2. PAVEMENT MARKING OFFSETS ARE TO FACE OF CURB.
 3. THE ABOVE CURVE DATA IS APPLICABLE WITHIN 10.00° DEFLECTION FROM 90.00°.
 4. RIGHT TURN CUT-OFF AND RADII TO BE REVIEWED / ADJUSTED TO ACCOMMODATE DESIGN TRUCK CLASSIFICATION (WB-21).
 5. LENGTH OF SOLID PAINTED GORE VARIES BASED ON VEHICLE ENTRY/EXIT ANGLES.
 6. TAPER / BAY LENGTHS ARE BASED ON TRAFFIC VOLUME.
 7. FOR MINIMUM DISTANCE BETWEEN INTERSECTION AND ACCESSES, SEE ACCESS MANAGEMENT GUIDELINES.



**RIGHT TURN STANDARD
ARTERIAL TO ARTERIAL
CHANNELIZED HIGH ENTRY ANGLE (YIELD CONDITION)**

DATE APPROVED: **2018**
SCALE: **N.T.S.**

DRAWN BY: **KSYC**
CHECKED BY: **JN**

APPROVED: *M.A.R.*

DRAWING NUMBER: **3100**

ALL DIMENSIONS
IN METRES UNLESS
OTHERWISE NOTED

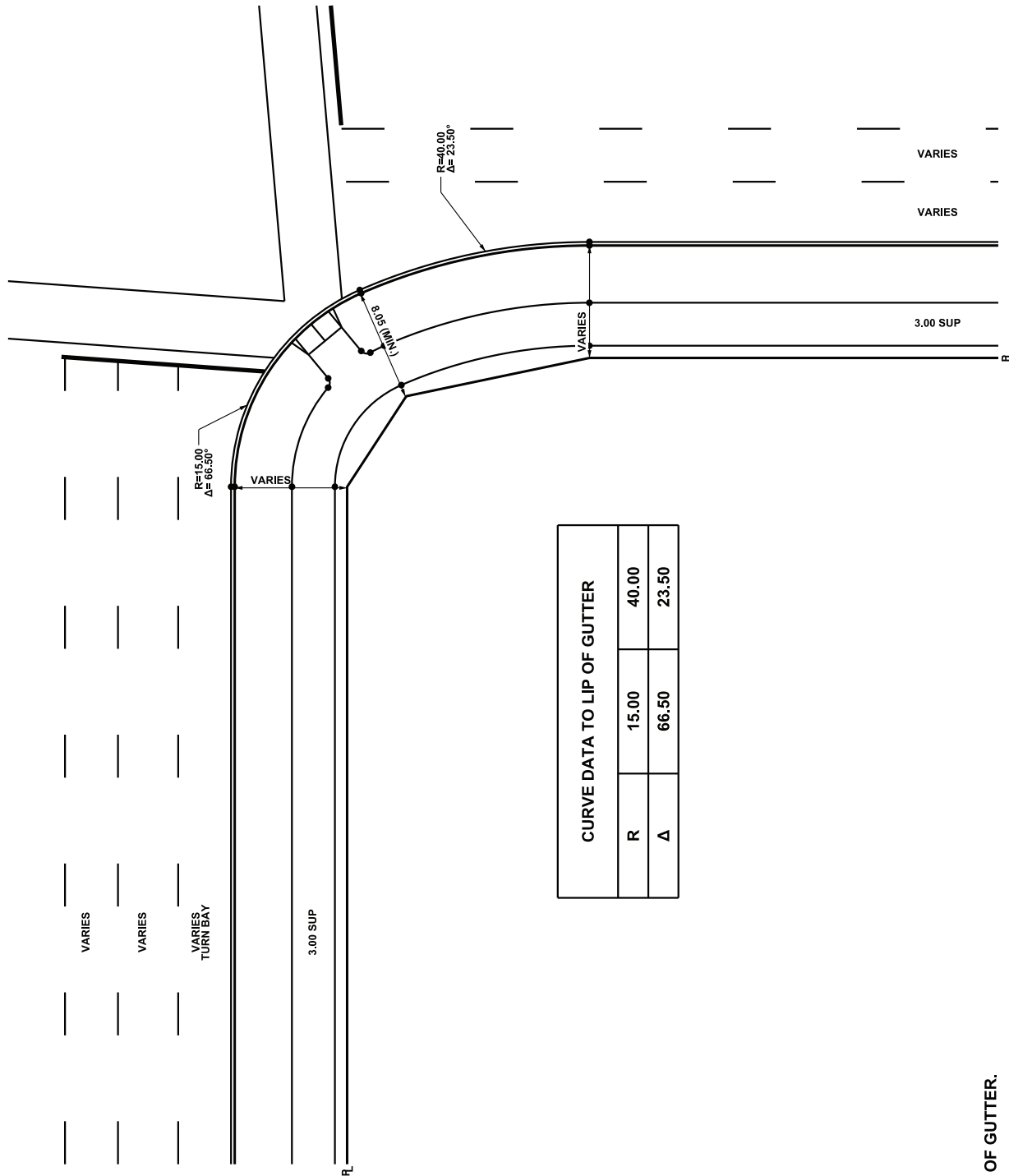

CURVE DATA TO LIP OF GUTTER	
R	15.00
Δ	66.50
R	40.00
Δ	23.50

NOTES:

1. ALL RADII ARE TO LIP OF GUTTER.
2. PAVEMENT MARKING OFFSETS ARE TO FACE OF CURB.
3. THE ABOVE CURVE DATA IS APPLICABLE WITHIN 10.00° DEFLECTION FROM 90.00°.
4. RIGHT TURN CUT-OFF TO BE REVIEWED / ADJUSTED TO ACCOMMODATE DESIGN TRUCK CLASSIFICATION (WB-21).
5. LENGTH OF SOLID PAINTED GORE VARIES BASED ON VEHICLE ENTRY/EXIT ANGLES.
6. TAPER / BAY LENGTHS ARE BASED ON TRAFFIC VOLUME.
7. FOR MINIMUM DISTANCE BETWEEN INTERSECTION AND ACCESSES, SEE ACCESS MANAGEMENT GUIDELINES.



STANDARD DRAWING

RIGHT TURN STANDARD
ARTERIAL TO ARTERIAL
UNCHANNELIZED SIMPLE CURVE (STOP CONDITION)

DATE APPROVED: **2018**
SCALE: **N.T.S.**

DRAWN BY: **KSYC**
CHECKED BY: **JN**

APPROVED: *M.R.*

DRAWING NUMBER: **3120**

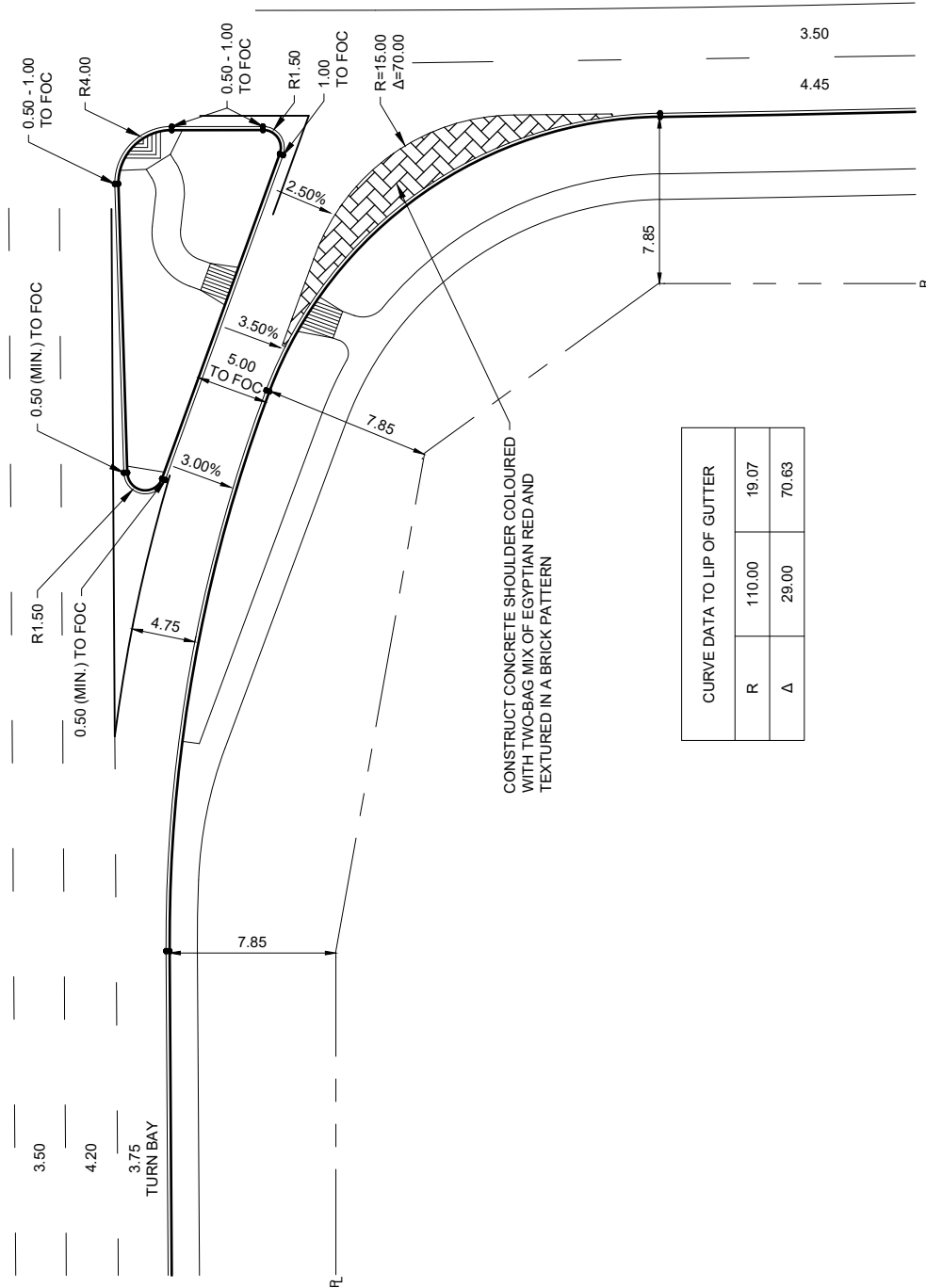

R	110.00	19.07
Δ	29.00	70.63

- NOTE:
1. ALL RADII ARE TO LIP OF GUTTER.
 2. PAVEMENT MARKINGS OFFSETS ARE TO FACE OF CURB.
 3. THE ABOVE CURVE DATA IS APPLICABLE WITHIN 10.00° DEFLECTION FROM 90.00°.
 4. LENGTH OF SOLID PAINTED GORE VARIES BASED ON VEHICLE ENTRY / EXIT ANGLES.
 5. TAPER / BAY LENGTHS ARE BASED ON TRAFFIC VOLUME.
 6. FOR MINIMUM DISTANCE BETWEEN INTERSECTION AND ACCESSES, SEE ACCESS MANAGEMENT GUIDELINES.

**ALL DIMENSIONS
IN METRES UNLESS
OTHERWISE NOTED**

RIGHT TURN WITH MOUNTABLE CURB



STANDARD DRAWING

DATE APPROVED: **2025**
SCALE: **N.T.S.**

DRAWN BY: **FR**
CHECKED BY: **JN**

APPROVED: *[Signature]*

DRAWING NUMBER: **3130**

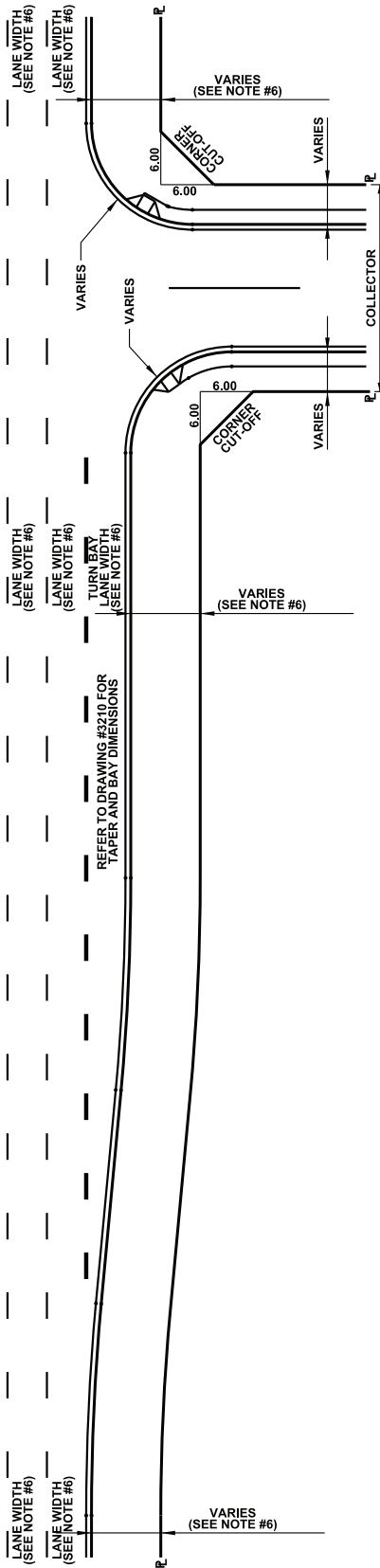

**TYPE I
RIGHT TURN BAY REQUIRED**

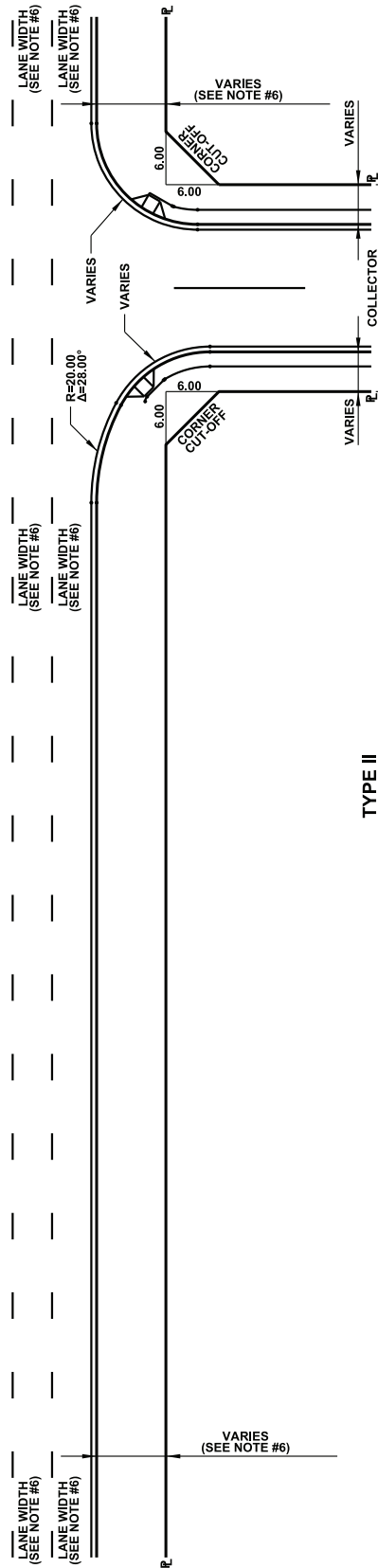

**TYPE II
RIGHT TURN BAY NOT REQUIRED**

MAIN LINE DESIGN SPEED = 70 km/hr
**ALL DIMENSIONS
IN METRES UNLESS
OTHERWISE NOTED**

NOTES:

1. ALL RADII ARE TO LIP OF GUTTER.
2. OFFSET DISTANCE ARE TO FACE OF CURB.
3. PAVEMENT MARKINGS ARE TO BE MEASURED FROM FACE OF CURB.
4. BAY LENGTH TO BE DETERMINED BY TRAFFIC SPEED AND VOLUME.
5. PROPERTY LINE REQUIREMENT WILL INCREASE IF BERM / FENCE IS REQUIRED.
6. LANE AND BOULEVARD WIDTHS BASED ON CONTEXT, SEE SECTION 3.2.2.3.



STANDARD DRAWING

**RIGHT TURN BAY STANDARD
ARTERIAL TO COLLECTOR**

DATE APPROVED: **2018**

DRAWN BY: **KSYC**

APPROVED: *M.L.R.*

DRAWING NUMBER: **3200**

SCALE: **N.T.S.**

CHECKED BY: **JN**

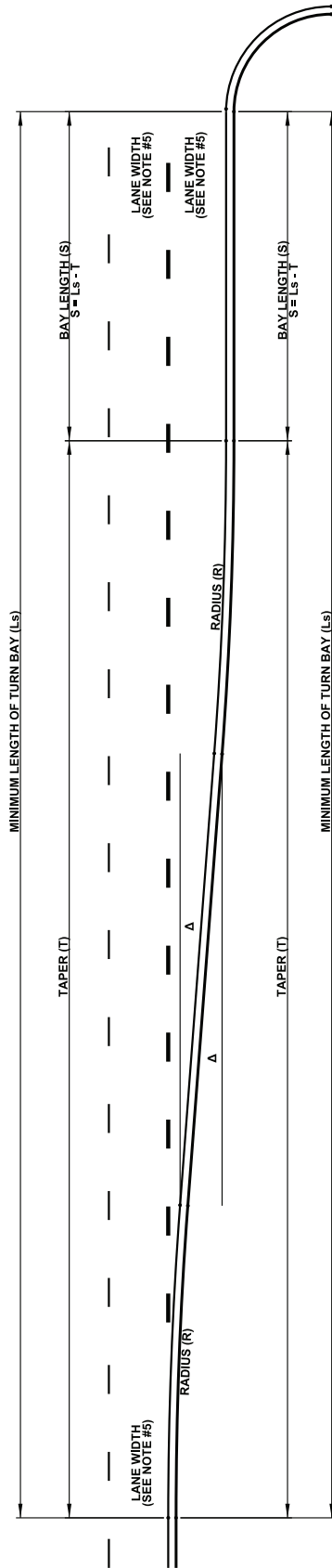

RIGHT TURN BAY DATA

DESIGN SPEED (km/hr)	T	Ls (MIN.)	R	Δ	TANGENT
50	60.00	90.00	216.68	5°17'00"	10.00
60	60.00	90.00	216.68	5°17'00"	10.00
70	60.00	110.00	216.68	5°17'00"	10.00
80	70.00	130.00	270.64	4°14'00"	10.00

NOTES:

1. ALL RADII ARE TO LIP OF GUTTER.
2. OFFSET DISTANCE ARE TO FACE OF CURB.
3. PAVEMENT MARKINGS ARE TO BE MEASURED FROM FACE OF CURB.
4. LENGTH OF BAY SHALL BE ADJUSTED SUCH THAT STORAGE = BAY LENGTH + 1/2 TAPER = (S) + 1/2 (T)
5. LANE WIDTHS BASED ON CONTEXT, SEE SECTION 3.2.2.3.

**ALL DIMENSIONS
IN METRES UNLESS
OTHERWISE NOTED**



STANDARD DRAWING

**RIGHT TURN BAY STANDARD
ARTERIAL TO ARTERIAL**

DATE APPROVED: **2018**

DRAWN BY: **KSYC**

APPROVED: *M.R.*

DRAWING NUMBER: **3210**

SCALE: **N.T.S.**

CHECKED BY: **JN**

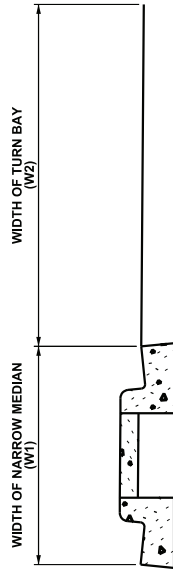
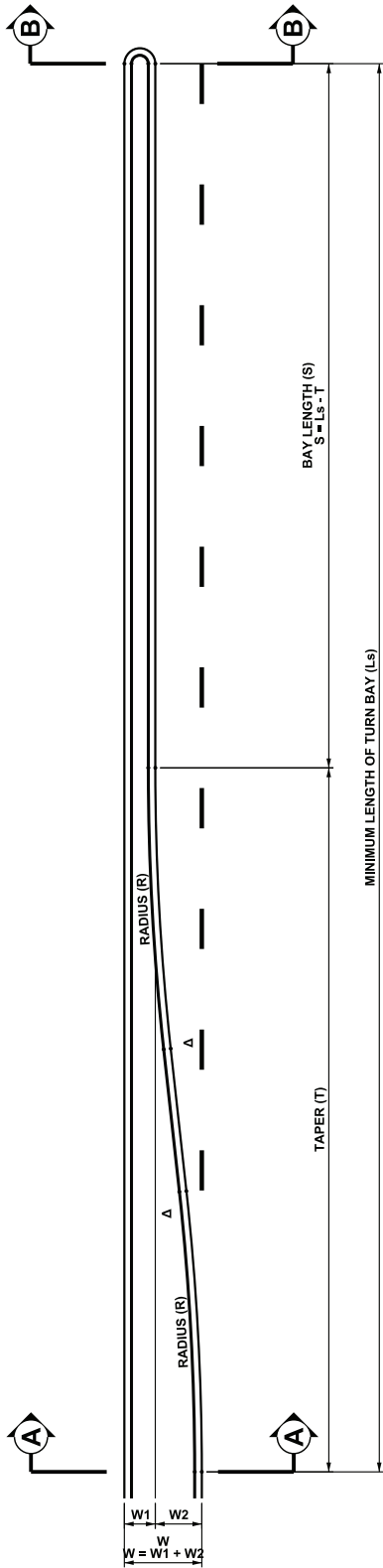

SECTION B-B

NARROW MEDIAN WIDTH			
0.25 GUTTER (RECOMMENDED)			
DESIGNED WIDTH	W	W1	W2
	5.00	1.70	VARIES

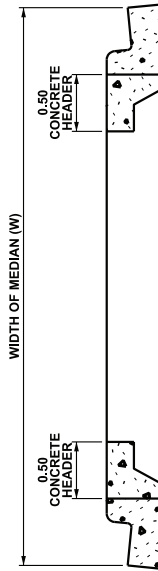

SECTION A-A

LEFT TURN BAY DATA					
DESIGN SPEED (km/hr)	T	Ls (MIN.)	R	A	TANGENT
50	60.00	90.00	242.85	4°43'00"	10.00
60	60.00	90.00	242.85	4°43'00"	10.00
70	60.00	110.00	242.85	4°43'00"	10.00
80	70.00	130.00	303.36	3°47'00"	10.00

NOTES:

1. ALL RADII ARE TO LIP OF GUTTER.
2. OFFSET DISTANCE ARE TO FACE OF CURB.
3. PAVEMENT MARKINGS ARE TO BE MEASURED FROM FACE OF CURB.
4. WIDTHS ARE TO BE MEASURED BASED ON 250mm GUTTER. FOR RETROFIT SITUATION (500mm GUTTER):
 $W1 = 1.2 \times (\text{FACE OF CURB TO FACE OF CURB})$
5. LENGTH OF BAY SHALL BE ADJUSTED SUCH THAT
 $\text{STORAGE} = \text{BAY LENGTH} + 1/2 \text{ TAPER} = (S) + 1/2 (T)$
6. LANE WIDTHS BASED ON CONTEXT, REFER TO SECTION 3.2.2.3.

ALL DIMENSIONS
IN METRES UNLESS
OTHERWISE NOTED

LEFT TURN BAY STANDARD
NARROW MEDIAN



STANDARD DRAWING

DATE APPROVED: 2018

DRAWN BY: KSYC

APPROVED: *M.R.*

DRAWING NUMBER: 3300

SCALE: N.T.S.

CHECKED BY: JN

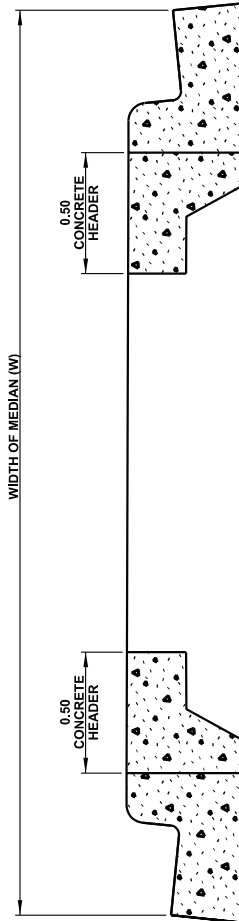
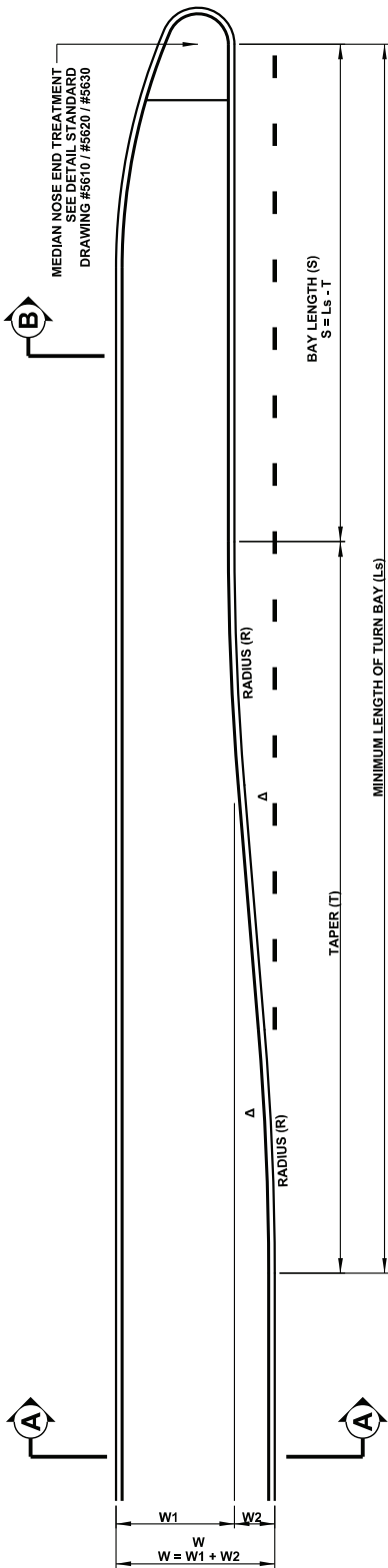

SECTION A-A

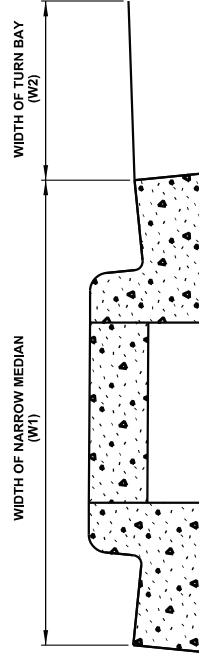

SECTION B-B

LEFT TURN BAY DATA					
DESIGN SPEED (km/hr)	T	Ls (MIN.)	R	Δ	TANGENT
50	60.00	90.00	242.85	4°43'00"	10.00
60	60.00	90.00	242.85	4°43'00"	10.00
70	60.00	110.00	242.85	4°43'00"	10.00
80	70.00	130.00	303.36	3°47'00"	10.00

WIDE MEDIAN WIDTH			
0.25 GUTTER (STANDARD)			
DESIGNED WIDTH	W	W1	W2
	12.40	9.10	VARIES

NOTES:

1. ALL RADII ARE TO LIP OF GUTTER.
2. OFFSET DISTANCE ARE TO FACE OF CURB.
3. PAVEMENT MARKINGS ARE TO BE MEASURED FROM FACE OF CURB.
4. WIDTHS ARE TO BE MEASURED BASED ON 250mm GUTTER. FOR RETROFIT SITUATION (500mm GUTTER):
 $W1 = 1.2 \times (\text{FACE OF CURB TO FACE OF CURB})$
 $\text{LENGTH OF BAY SHALL BE ADJUSTED SUCH THAT STORAGE} = \text{BAY LENGTH} + 1/2 \text{ TAPER} = (S) + 1/2 (T)$
5. LANE WIDTHS ARE BASED ON CONTEXT. REFER SECTION 3.2.2.3.

ALL DIMENSIONS IN METRES UNLESS OTHERWISE NOTED

LEFT TURN BAY STANDARD WIDE MEDIAN



DATE APPROVED: 2018
 SCALE: N.T.S.

DRAWN BY: KSYC
 CHECKED BY: JN

APPROVED: *M.A.R.*

DRAWING NUMBER: 3310

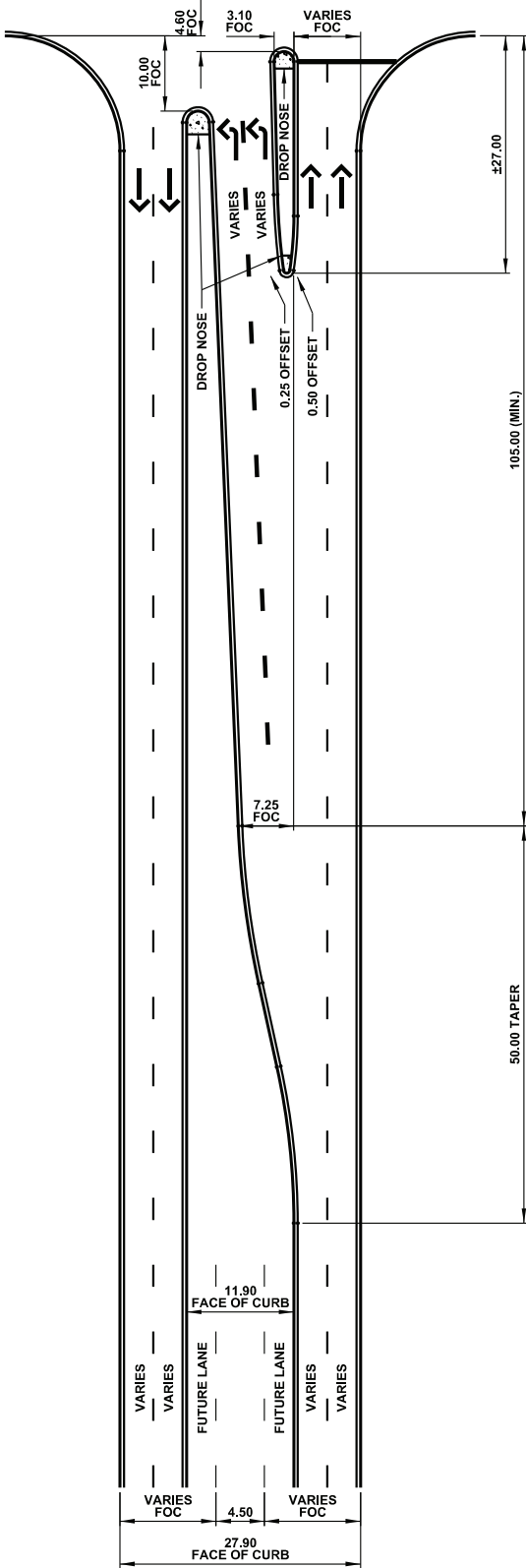

A. TWO LANE

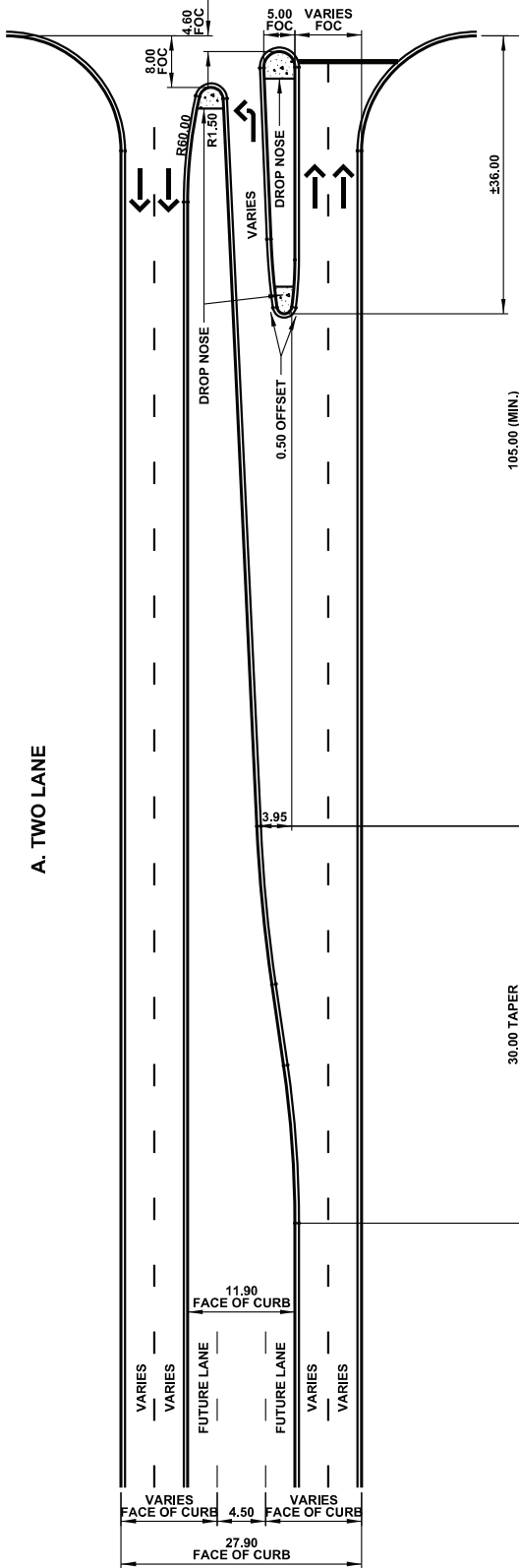

B. ONE LANE

NOTES:

1. MEDIAN WIDTHS ARE BASED ON CURBED MEDIANS.
2. ALL NOSE LOCATIONS SHOULD BE CHECKED WITH TURNING VEHICLE TEMPLATES.
3. CONSTRUCT MEDIAN NOSE END TREATMENT (DRAWING #5610 / #5620 / #5630) WHERE APPLICABLE.
4. LENGTH OF BAY SHALL BE ADJUSTED TO ACCOMMODATE QUEUES SUCH THAT STORAGE = BAY + 1/2 TAPER
5. LANE WIDTHS BASED ON CONTEXT, REFER TO SECTION 3.2.2.3.
6. LANE WIDTH MEASUREMENTS ARE TO FACE OF CURB.
7. ISLAND SETBACK TO BE ADJUSTED BASED ON SIDEWALK LOCATION AND CONFIGURATION.

ALL DIMENSIONS
IN METRES UNLESS
OTHERWISE NOTED

LEFT TURN STANDARD
CHANNELIZED SLOT



STANDARD DRAWING

DATE APPROVED: 2018
SCALE: N.T.S.

DRAWN BY: KSYC
CHECKED BY: JN

APPROVED: *M.A.R.*

DRAWING NUMBER: 3320

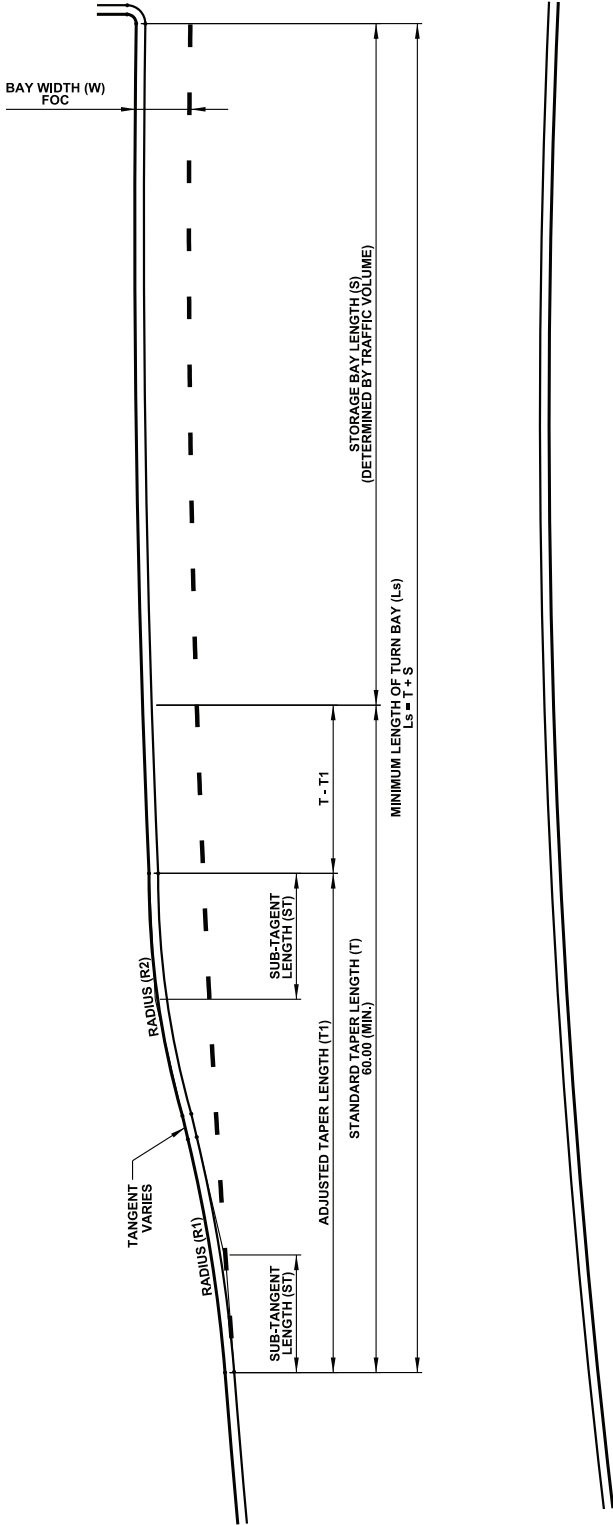

TURN BAY DATA					
DESIGN SPEED (km/hr)	MAIN LINE CURVE DATA (RADIUS)	ADJUSTED TAPER (T1)	SUB-TANGENT (ST)	RADIUS (R1)	RADIUS (R2)
50 - 80	TAN - 1165.00	STANDARD (DWG. 3300)	10.00	VARIES	VARIES
50 - 80	1165.00 - 580.00	35.00	7.00	VARIES	VARIES
50 - 70	580.00 - 350.00	30.00	6.00	VARIES	VARIES
50 - 70	350.00 - 250.00	25.00	5.00	VARIES	VARIES
50 - 60	250.00 - 145.00	20.00	4.00	VARIES	VARIES

NOTES:

1. MINIMUM LENGTH OF TAPER / TURN BAY IS BASED ON STANDARD DESIGN SPEED AND TRAFFIC VOLUME. STANDARD TAPER LENGTH = 60.00 (MIN.).
2. TAPER / BAY WIDTH SEE DRAWING #3300 / #3310.
3. WHERE MAINLINE IS CURVED, TAPER IS REDUCED TO LENGTH SHOWN IN TABLE AND STORAGE LENGTH IS INCREASED BY EQUAL AMOUNT. OVERALL TURN BAY LENGTH DOES NOT CHANGE.

ALL DIMENSIONS
IN METRES UNLESS
OTHERWISE NOTED

RIGHT AND LEFT TURN BAY STANDARD
CURVED MAIN LINE



STANDARD DRAWING

DATE APPROVED: **2018**

DRAWN BY: **KSYC**

APPROVED: *M.R.*

DRAWING NUMBER: **3350**

SCALE: **N.T.S.**

CHECKED BY: **JN**

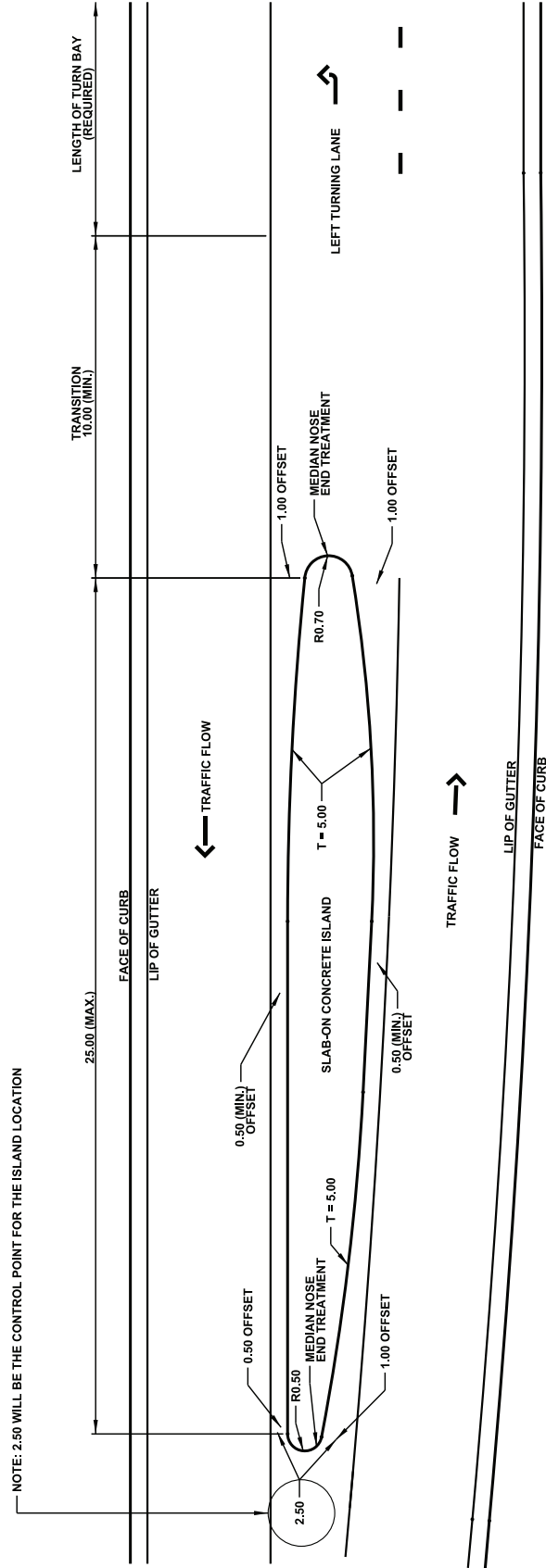

ALL DIMENSIONS
IN METRES UNLESS
OTHERWISE NOTED



ISLAND LAYOUT
FOR
INTRODUCTION OF CHANNELIZATION

DATE APPROVED: **2018**
SCALE: **N.T.S.**

DRAWN BY: **KSYC**
CHECKED BY: **JN**

APPROVED: *M.R.*

DRAWING NUMBER: **3400**

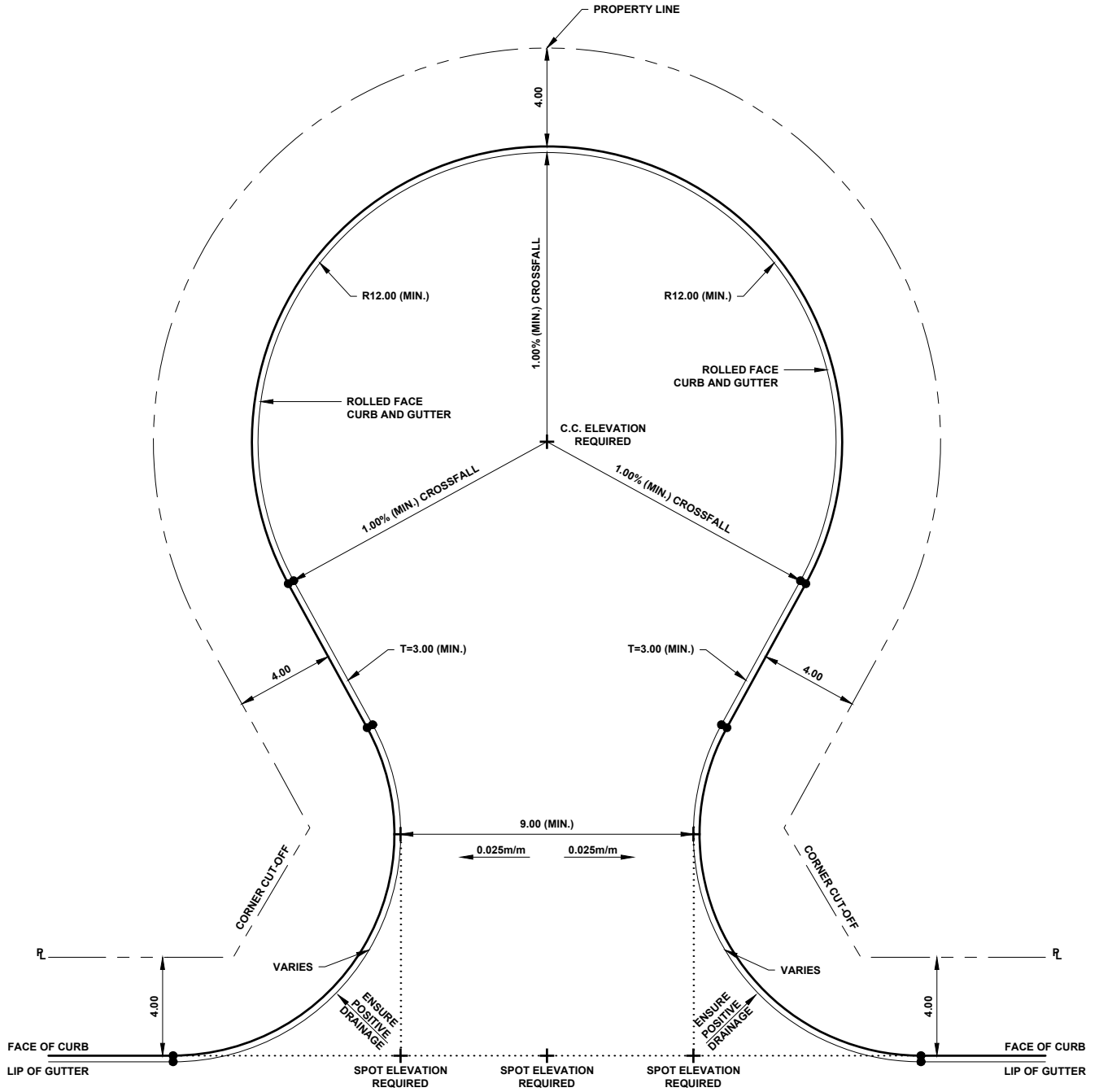

NOTE:

1. PROVIDE ELEVATION FOR ALL CROSS SYMBOL (+) SHOWN.
2. 1.00% (MIN.) LONGITUDINAL GRADE REQUIRED ALONG CUL-DE-SAC AND CURB RADII.
3. ALL RADII ARE TO LIP OF GUTTER.
4. SIDEWALK TO BE PROVIDED ON ALL SIDES OF CUL-DE-SAC AS PER DRAWING #3540.

**ALL DIMENSIONS
IN METRES UNLESS
OTHERWISE NOTED**



STANDARD DRAWING

**RESIDENTIAL CUL-DE-SAC
(WITHOUT ISLAND)**

DATE APPROVED: 2025	DRAWN BY: FR	APPROVED: 	DRAWING NUMBER: 3500
SCALE: N.T.S.	CHECKED BY: JN		

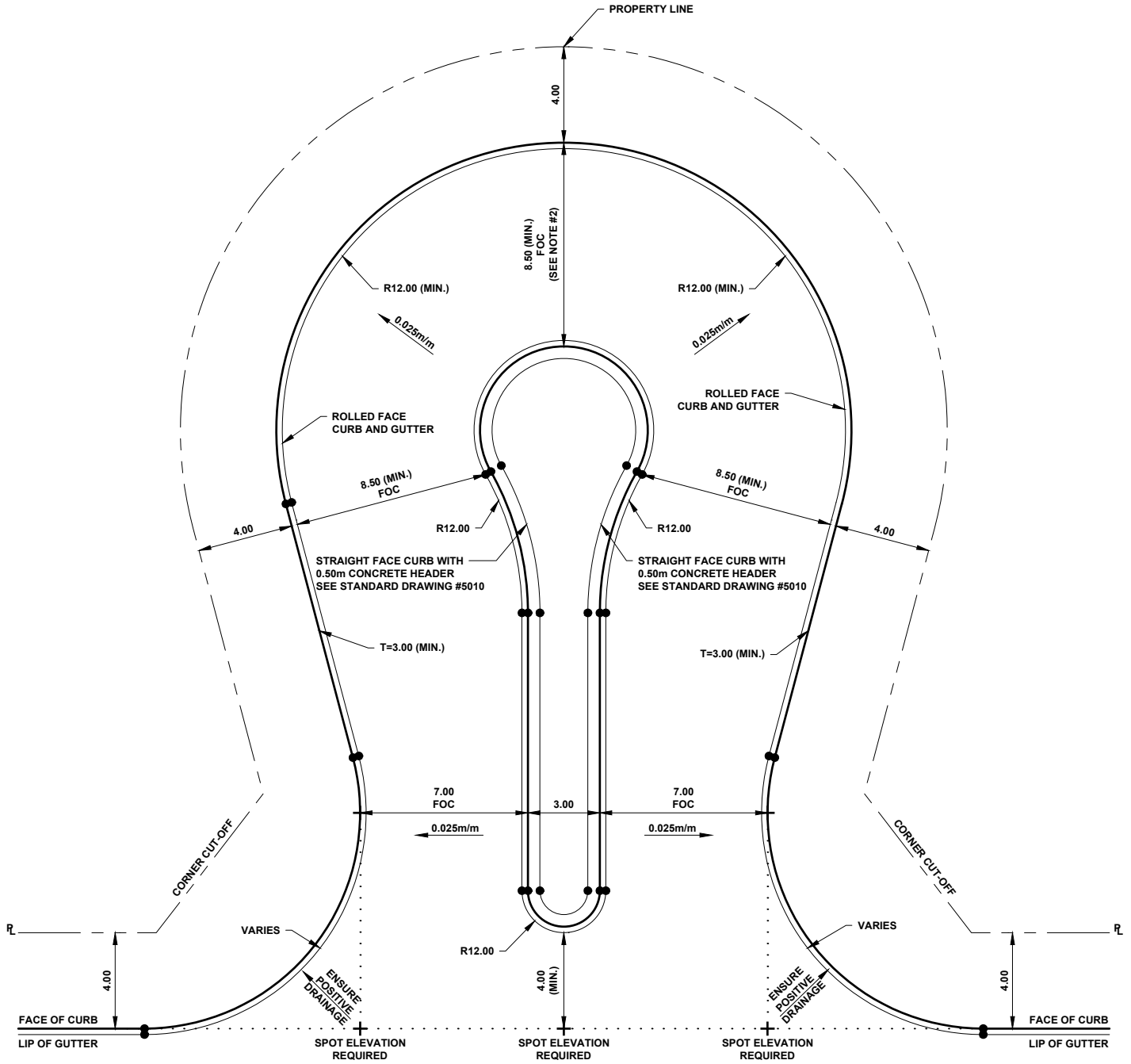

NOTE:

1. PROVIDE ELEVATION FOR ALL CROSS SYMBOL (+) SHOWN.
2. 1.00% (MIN.) LONGITUDINAL GRADE REQUIRED ALONG CUL-DE-SAC AND CURB RADII.
3. ALL RADII ARE TO LIP OF GUTTER.
4. PROVISION ALLOTTED FOR PARALLEL PARKING AROUND 12.00m RADIUS. NO PARKING ON INSIDE CURBLINE.
5. CONCRETE HEADER TO BE POURED MONOLITHICALLY WITH CURB AND GUTTER.
6. SIDEWALK TO BE PROVIDED ON ALL SIDES OF CUL-DE-SAC AS PER DRAWING #3540

**ALL DIMENSIONS
IN METRES UNLESS
OTHERWISE NOTED**

STANDARD DRAWING

**RESIDENTIAL CUL-DE-SAC
(CIRCULAR ISLAND)**

DATE APPROVED: **2025**
SCALE: **N.T.S.**

DRAWN BY: **FR**
CHECKED BY: **JN**

APPROVED: *[Signature]*

DRAWING NUMBER: **3510**

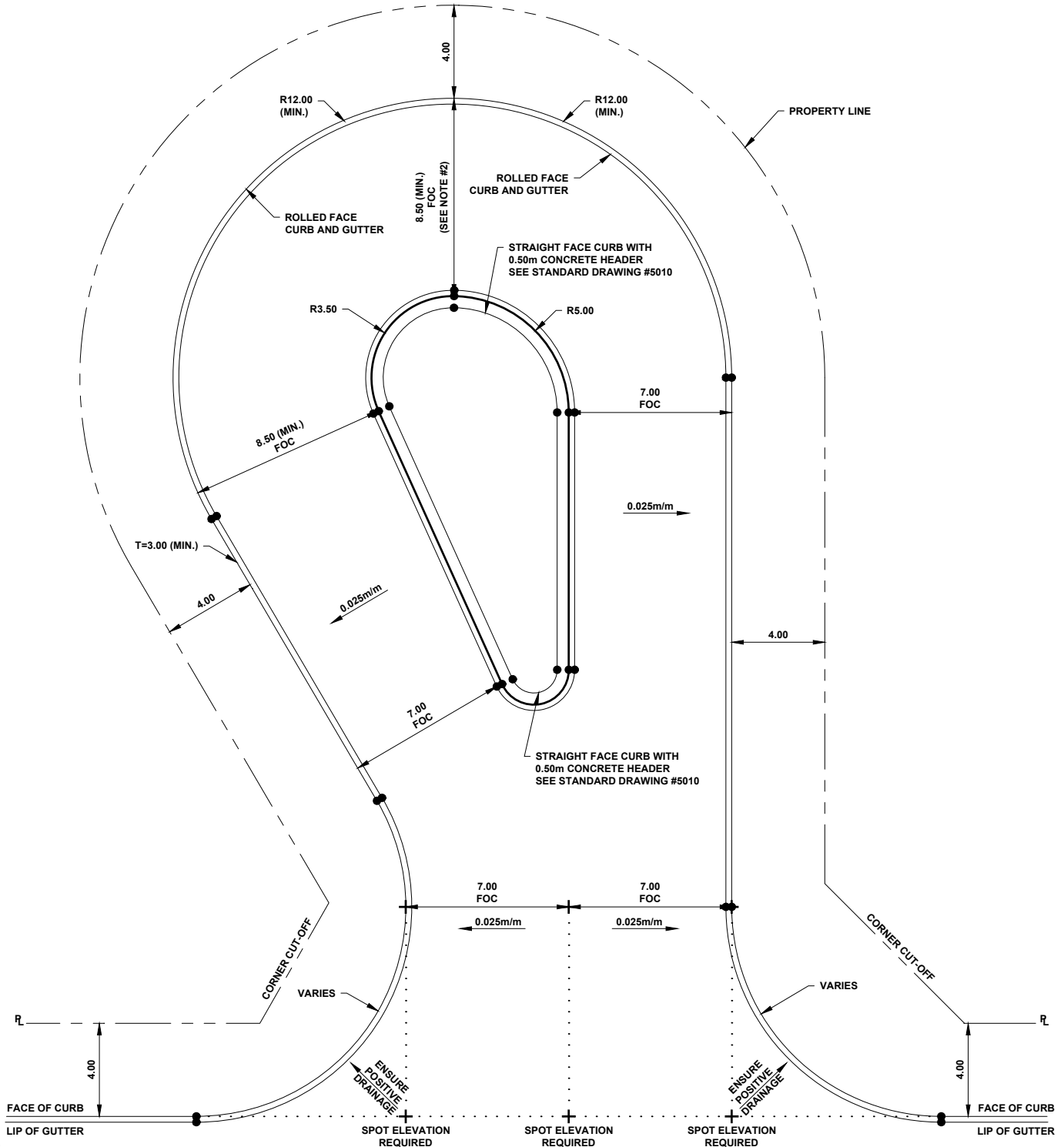

NOTE:

1. PROVIDE ELEVATION FOR ALL CROSS SYMBOL (+) SHOWN.
2. 1.00% (MIN.) LONGITUDINAL GRADE REQUIRED ALONG CUL-DE-SAC AND CURB RADII.
3. ALL RADII ARE TO LIP OF GUTTER.
4. PROVISION ALLOTTED FOR PARALLEL PARKING AROUND 12.00m RADIUS. NO PARKING ON INSIDE CURBLINE.
5. CONCRETE HEADER TO BE POURED MONOLITHICALLY WITH CURB AND GUTTER.
6. SIDEWALK TO BE PROVIDED ON ALL SIDES OF CUL-DE-SAC AS PER DRAWING #3540

**ALL DIMENSIONS
IN METRES UNLESS
OTHERWISE NOTED**



STANDARD DRAWING

**RESIDENTIAL CUL-DE-SAC
(CIRCULAR OFFSET ISLAND)**

DATE APPROVED: **2025**

SCALE: **N.T.S.**

DRAWN BY: **FR**

CHECKED BY: **JN**

APPROVED: 

DRAWING NUMBER: **3520**

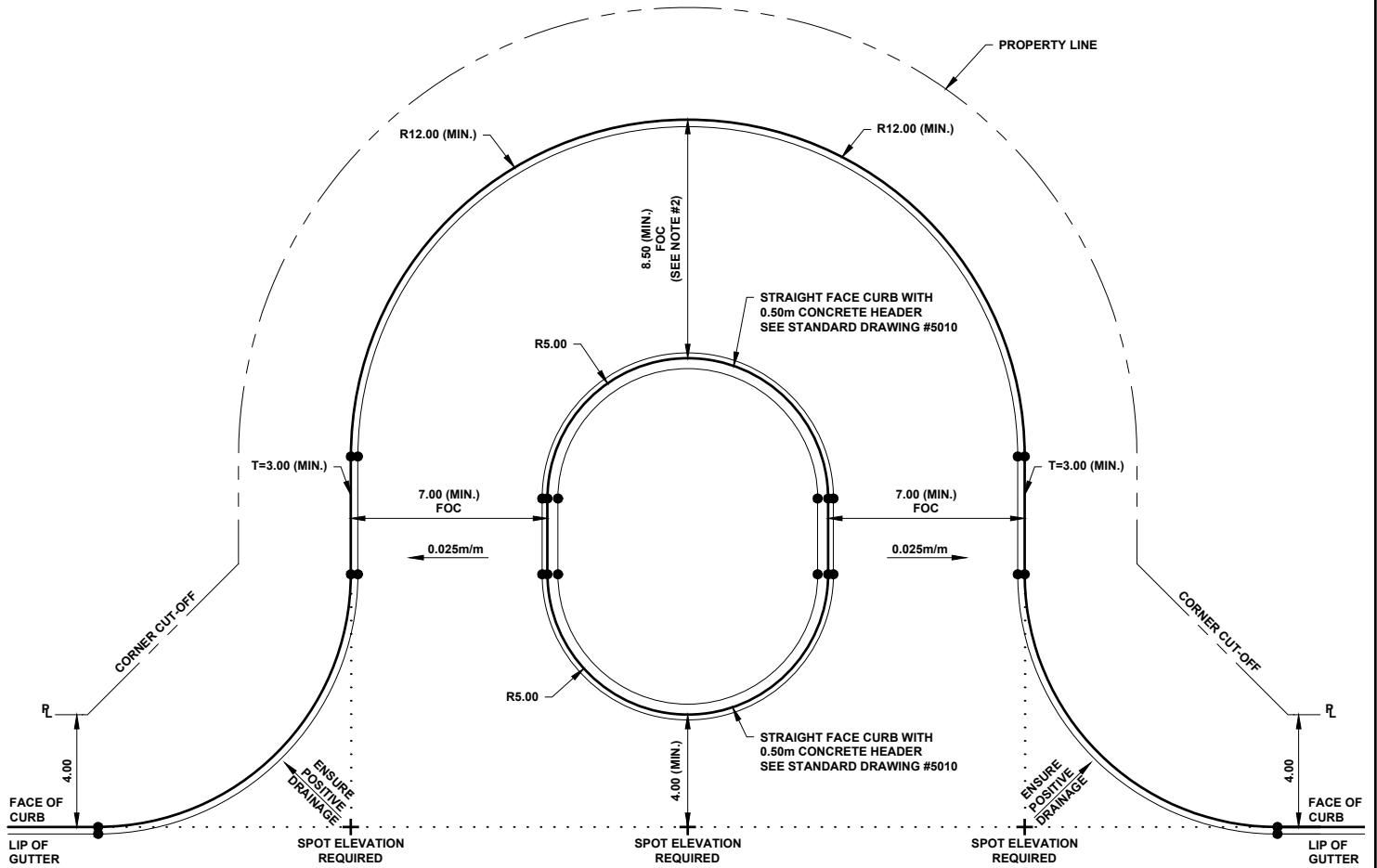

NOTE:

1. PROVIDE ELEVATION FOR ALL CROSS SYMBOL (+) SHOWN.
2. 1.00% (MIN.) LONGITUDINAL GRADE REQUIRED ALONG CUL-DE-SAC AND CURB RADII.
3. ALL RADII ARE TO LIP OF GUTTER.
4. PROVISION ALLOTTED FOR PARALLEL PARKING AROUND 12.00m RADIUS. NO PARKING ON INSIDE CURBLINE.
5. CONCRETE HEADER TO BE POURED MONOLITHICALLY WITH CURB AND GUTTER.
6. SIDEWALK TO BE PROVIDED ON ALL SIDES OF EYEBROW AS PER DRAWING #3540

**ALL DIMENSIONS
IN METRES UNLESS
OTHERWISE NOTED**



STANDARD DRAWING

**RESIDENTIAL EYEBROW
(CIRCULAR ISLAND)**

DATE APPROVED: **2025**
SCALE: **N.T.S.**

DRAWN BY: **FR**
CHECKED BY: **JN**

APPROVED: 

DRAWING NUMBER: **3530**

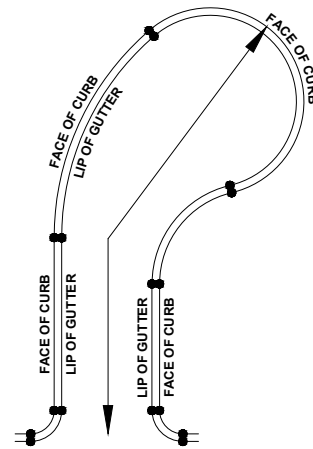
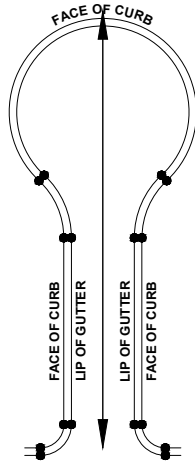
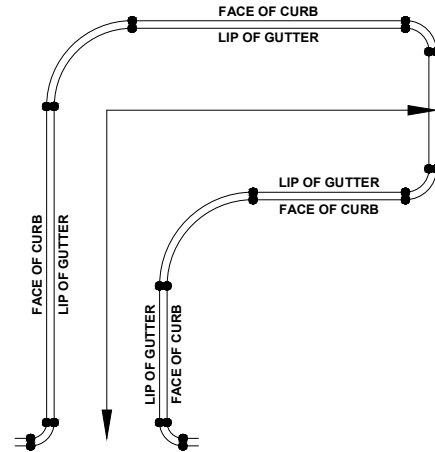
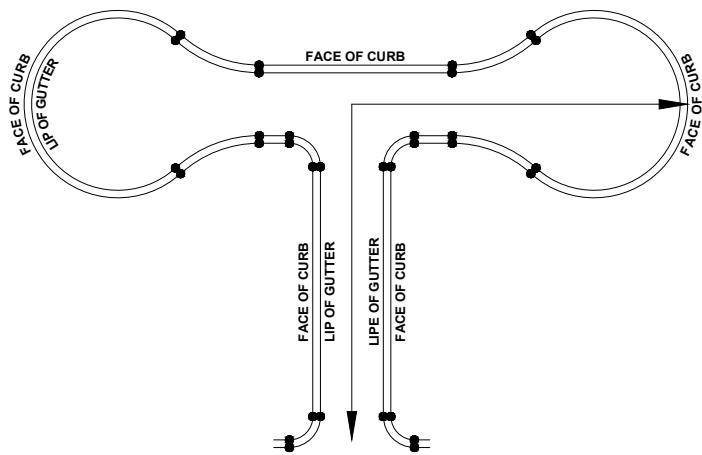

NOTE:
ALL CUL-DE-SAC REQUIRE SIDEWALK ON BOTH SIDES.

**ALL DIMENSIONS
IN METRES UNLESS
OTHERWISE NOTED**

STANDARD DRAWING

**SIDEWALK REQUIREMENTS
CUL-DE-SAC**

DATE APPROVED: **2025**
SCALE: **N.T.S.**

DRAWN BY: **FR**
CHECKED BY: **JN**

APPROVED: *[Signature]*

DRAWING NUMBER: **3540**

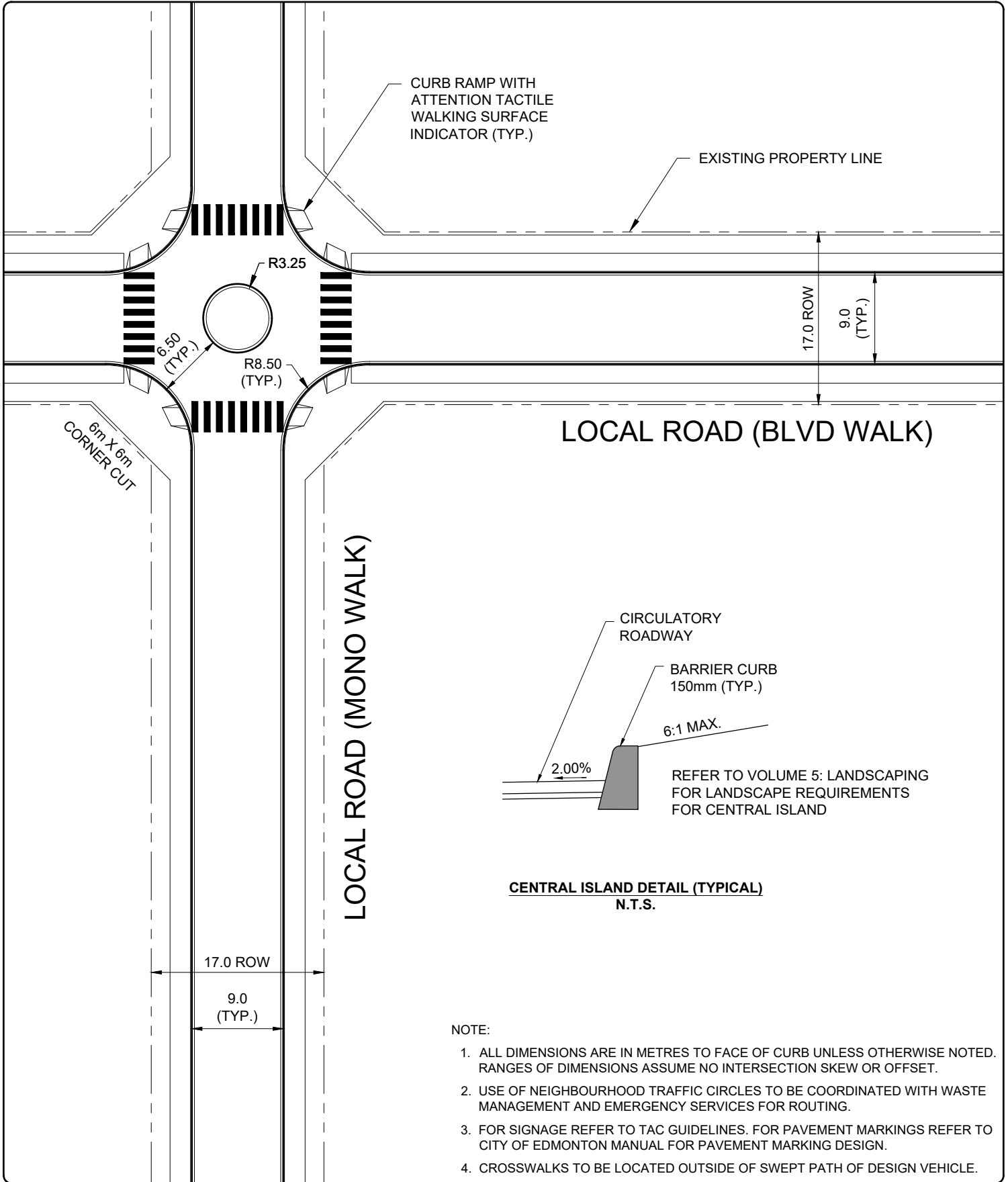

STANDARD DRAWING

NEIGHBOURHOOD TRAFFIC CIRCLE

DATE APPROVED: **2025**
SCALE: **N.T.S.**

DRAWN BY: **FR**
CHECKED BY: **JN**

APPROVED: *[Signature]*

DRAWING NUMBER: **3700**

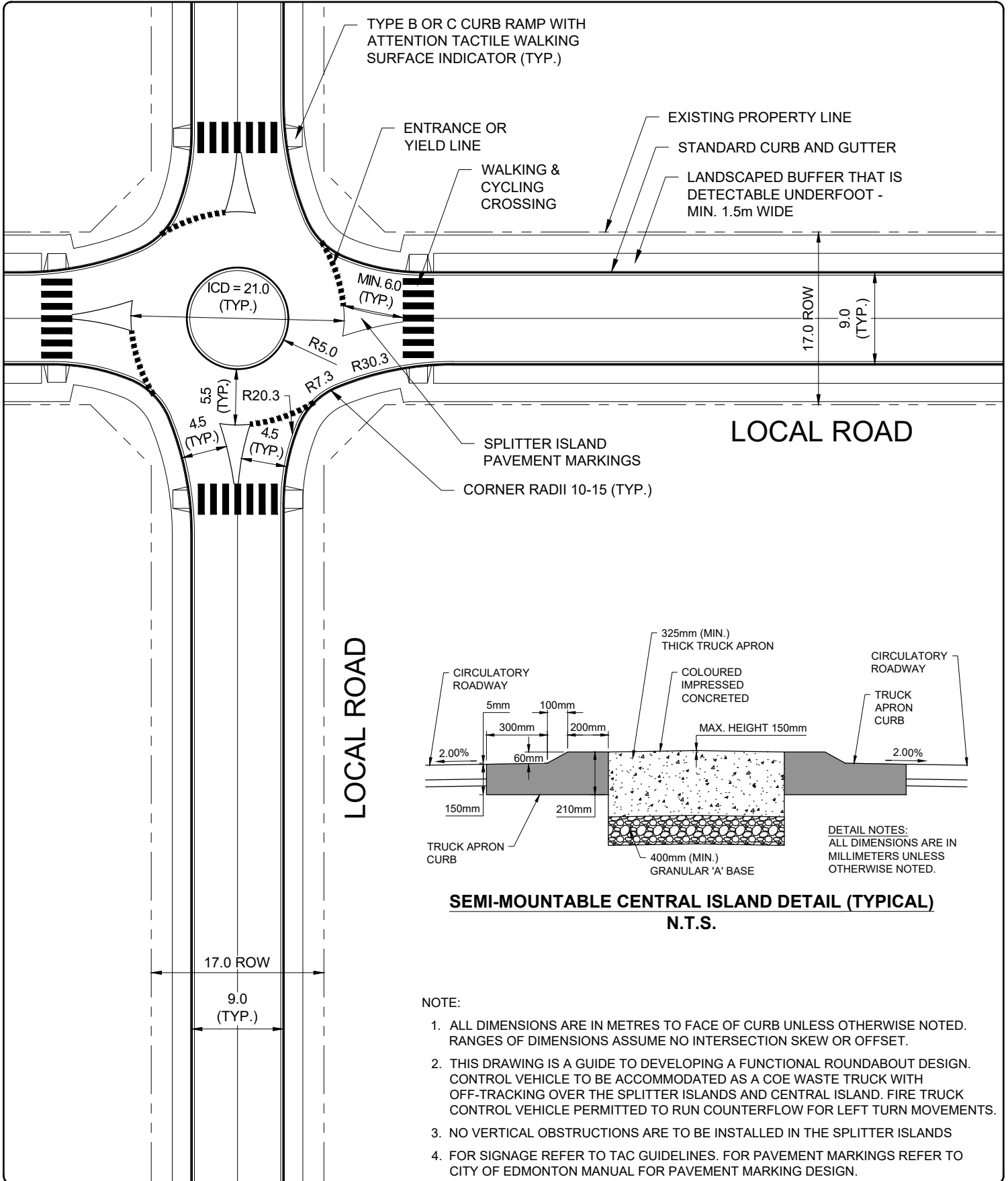

SEMI-MOUNTABLE CENTRAL ISLAND DETAIL (TYPICAL)
N.T.S.

NOTE:

1. ALL DIMENSIONS ARE IN METRES TO FACE OF CURB UNLESS OTHERWISE NOTED. RANGES OF DIMENSIONS ASSUME NO INTERSECTION SKEW OR OFFSET.
2. THIS DRAWING IS A GUIDE TO DEVELOPING A FUNCTIONAL ROUNDABOUT DESIGN. CONTROL VEHICLE TO BE ACCOMMODATED AS A COE WASTE TRUCK WITH OFF-TRACKING OVER THE SPLITTER ISLANDS AND CENTRAL ISLAND. FIRE TRUCK CONTROL VEHICLE PERMITTED TO RUN COUNTERFLOW FOR LEFT TURN MOVEMENTS.
3. NO VERTICAL OBSTRUCTIONS ARE TO BE INSTALLED IN THE SPLITTER ISLANDS
4. FOR SIGNAGE REFER TO TAC GUIDELINES. FOR PAVEMENT MARKINGS REFER TO CITY OF EDMONTON MANUAL FOR PAVEMENT MARKING DESIGN.

STANDARD DRAWING

**MINI-ROUNDABOUT
(WITHIN RIGHT-OF-WAY)**

DATE APPROVED: 2025	DRAWN BY: FR	APPROVED: 	DRAWING NUMBER: 3710
SCALE: N.T.S.	CHECKED BY: JN		

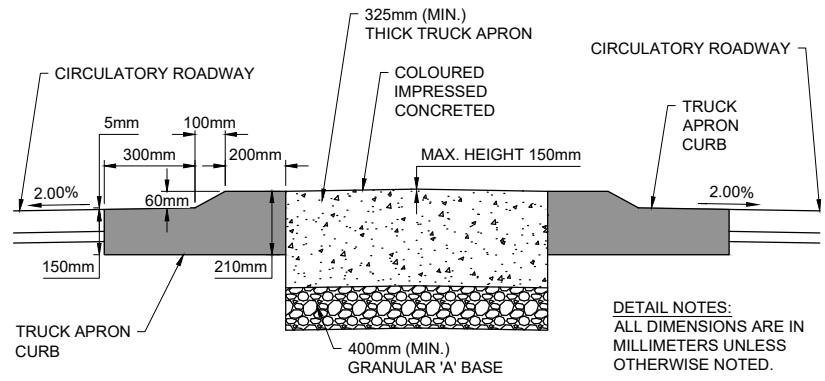
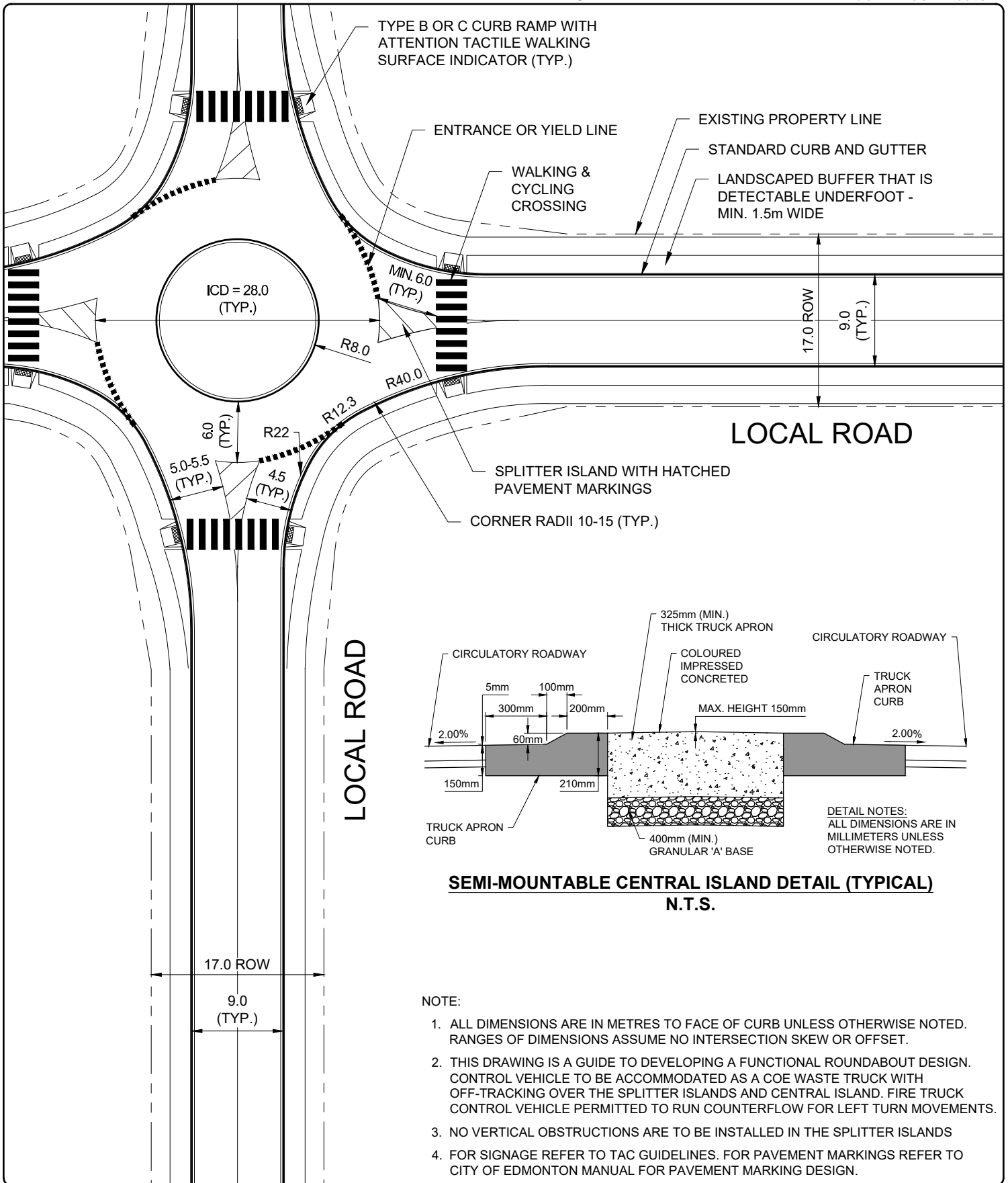

SEMI-MOUNTABLE CENTRAL ISLAND DETAIL (TYPICAL)
N.T.S.

NOTE:

1. ALL DIMENSIONS ARE IN METRES TO FACE OF CURB UNLESS OTHERWISE NOTED. RANGES OF DIMENSIONS ASSUME NO INTERSECTION SKEW OR OFFSET.
2. THIS DRAWING IS A GUIDE TO DEVELOPING A FUNCTIONAL ROUNDABOUT DESIGN. CONTROL VEHICLE TO BE ACCOMMODATED AS A COE WASTE TRUCK WITH OFF-TRACKING OVER THE SPLITTER ISLANDS AND CENTRAL ISLAND. FIRE TRUCK CONTROL VEHICLE PERMITTED TO RUN COUNTERFLOW FOR LEFT TURN MOVEMENTS.
3. NO VERTICAL OBSTRUCTIONS ARE TO BE INSTALLED IN THE SPLITTER ISLANDS
4. FOR SIGNAGE REFER TO TAC GUIDELINES. FOR PAVEMENT MARKINGS REFER TO CITY OF EDMONTON MANUAL FOR PAVEMENT MARKING DESIGN.

STANDARD DRAWING

**MINI-ROUNDABOUT
(ADDITIONAL RIGHT-OF-WAY)**

DATE APPROVED: 2025	DRAWN BY: FR	APPROVED: 	DRAWING NUMBER: 3711
SCALE: N.T.S.	CHECKED BY: JN		

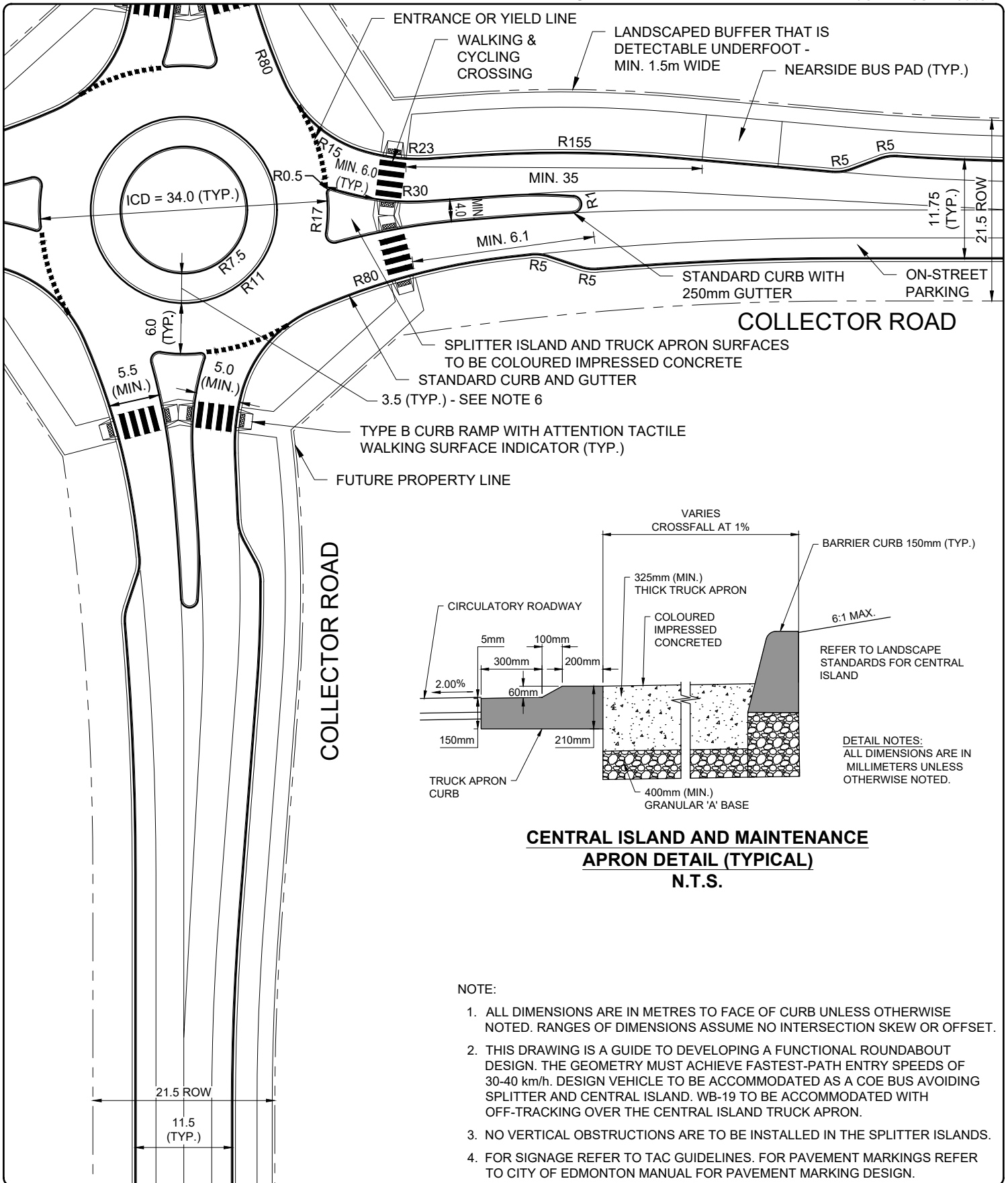

CENTRAL ISLAND AND MAINTENANCE APRON DETAIL (TYPICAL)
N.T.S.

NOTE:

1. ALL DIMENSIONS ARE IN METRES TO FACE OF CURB UNLESS OTHERWISE NOTED. RANGES OF DIMENSIONS ASSUME NO INTERSECTION SKEW OR OFFSET.
2. THIS DRAWING IS A GUIDE TO DEVELOPING A FUNCTIONAL ROUNDABOUT DESIGN. THE GEOMETRY MUST ACHIEVE FASTEST-PATH ENTRY SPEEDS OF 30-40 km/h. DESIGN VEHICLE TO BE ACCOMMODATED AS A COE BUS AVOIDING SPLITTER AND CENTRAL ISLAND. WB-19 TO BE ACCOMMODATED WITH OFF-TRACKING OVER THE CENTRAL ISLAND TRUCK APRON.
3. NO VERTICAL OBSTRUCTIONS ARE TO BE INSTALLED IN THE SPLITTER ISLANDS.
4. FOR SIGNAGE REFER TO TAC GUIDELINES. FOR PAVEMENT MARKINGS REFER TO CITY OF EDMONTON MANUAL FOR PAVEMENT MARKING DESIGN.

STANDARD DRAWING

SINGLE-LANE ROUNDABOUT

DATE APPROVED: 2025	DRAWN BY: FR	APPROVED: 	DRAWING NUMBER: 3715
SCALE: N.T.S.	CHECKED BY: JN		

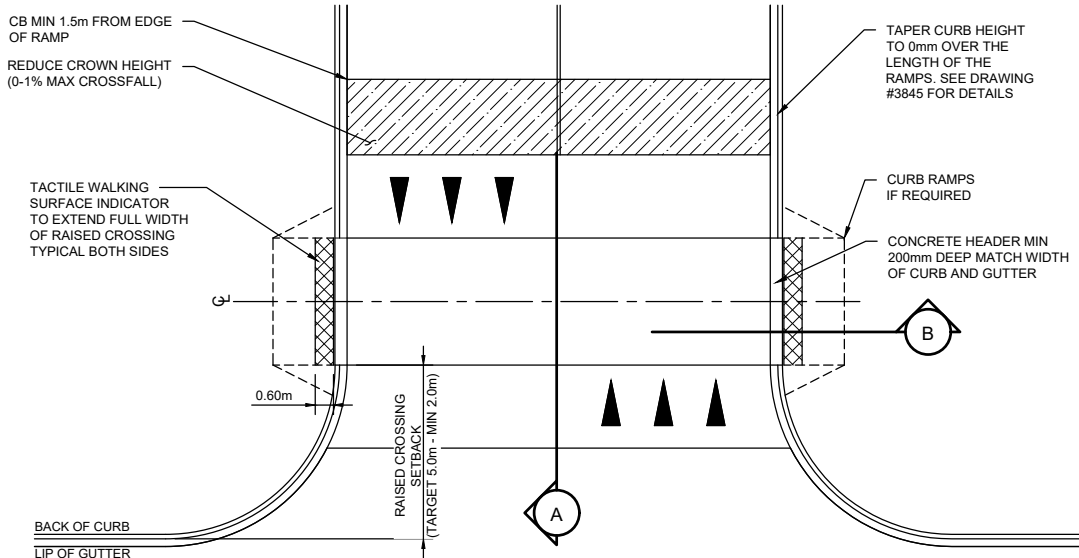

PLAN

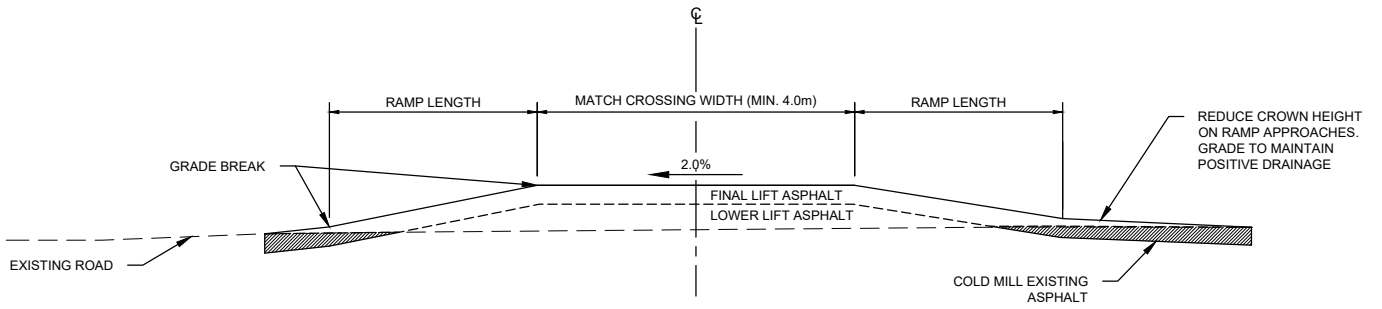

SECTION A

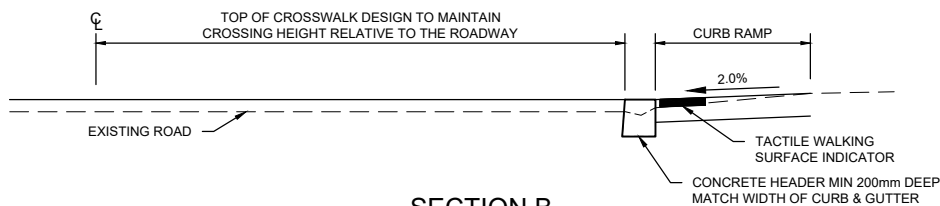

SECTION B

NOTE:

1. MINIMUM CROSSING WIDTH 2.50m
2. WIDTH OF RAISED CROSSING TO BE MINIMUM 4.0m OR MATCH WIDTH OF CROSSWALK/SIDEWALK, SHARED PATHWAY, BIKE PATH AND/OR RAISED PROTECTED BIKE LANE, WHICHEVER IS GREATER
3. SEE SECTION 3.6.4.3 FOR RAMP LENGTH AND GRADE BREAK REQUIREMENTS

NOTES:

- SUPPLEMENTAL SIGNAGE AND PAINT MARKINGS AS PER LATEST EDITION OF THE CITY OF EDMONTON MANUAL FOR PAVEMENT MARKING DESIGN, AND THE MANUAL FOR UNIFORM TRAFFIC CONTROL DEVICES OF CANADA. MARKINGS TO BE CONFIRMED BY ENGINEER
- MAY REQUIRE CHANGES TO DRAINAGE DESIGN

**ALL DIMENSIONS
IN MILLIMETRES UNLESS
OTHERWISE NOTED**

STANDARD DRAWING

RAISED CROSSING AT INTERSECTION - ASPHALT (RETROFIT)

DATE APPROVED: **2025**
SCALE: **N.T.S.**

DRAWN BY: **FR**
CHECKED BY: **JN**

APPROVED: *[Signature]*

DRAWING NUMBER: **3800**

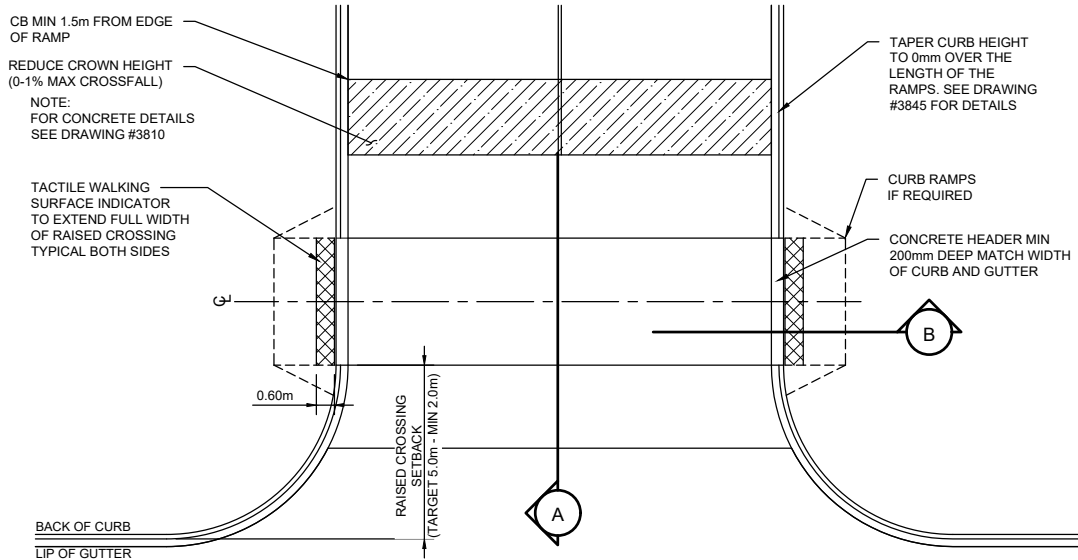

PLAN

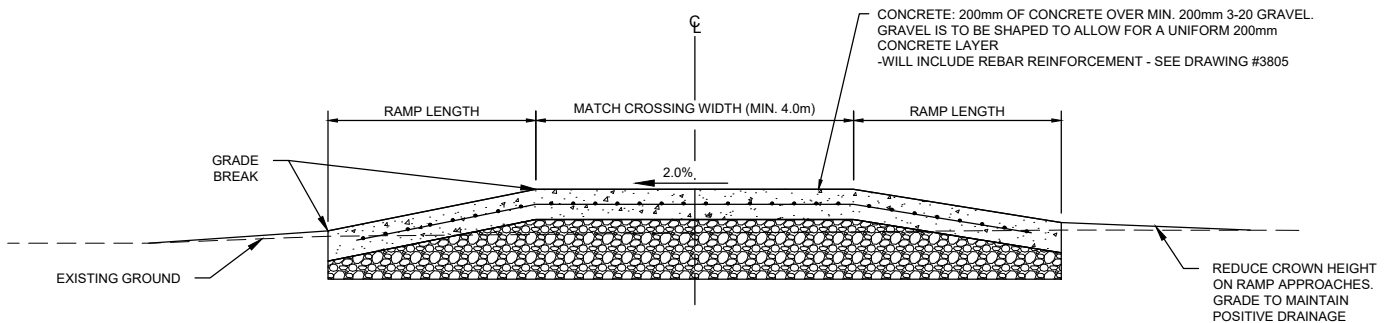

SECTION A

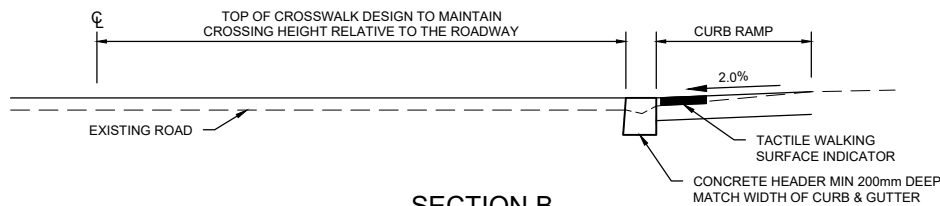

SECTION B

- NOTES:**
- SUPPLEMENTAL SIGNAGE AND PAINT MARKINGS AS PER LATEST EDITION OF THE CITY OF EDMONTON MANUAL FOR PAVEMENT MARKING DESIGN, AND THE MANUAL FOR UNIFORM TRAFFIC CONTROL DEVICES OF CANADA. MARKINGS TO BE CONFIRMED BY ENGINEER
 - MAY REQUIRE CHANGES TO DRAINAGE DESIGN

- NOTE:**
- WIDTH OF RAISED CROSSING TO BE MINIMUM 4.0m OR MATCH WIDTH OF CROSSWALK/SIDEWALK, SHARED PATHWAY, BIKE PATH AND/OR RAISED PROTECTED BIKE LANE, WHICHEVER IS GREATER
 - SEE SECTION 3.6.4.3 FOR RAMP LENGTH AND GRADE BREAK REQUIREMENTS

ALL DIMENSIONS IN MILLIMETRES UNLESS OTHERWISE NOTED

STANDARD DRAWING

RAISED CROSSING AT INTERSECTION - CONCRETE

DATE APPROVED: **2025**
SCALE: **N.T.S.**

DRAWN BY: **FR**
CHECKED BY: **JN**

APPROVED: *[Signature]*

DRAWING NUMBER: **3805**

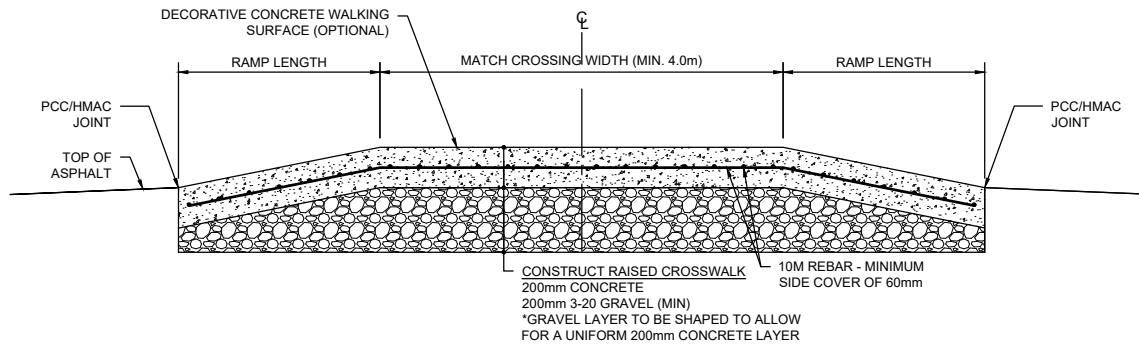
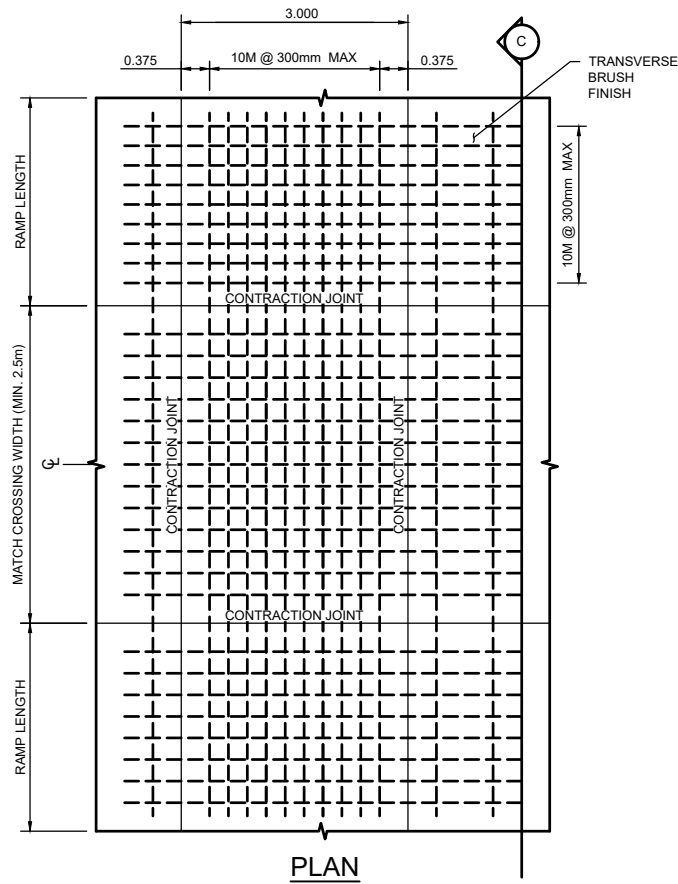

- NOTES:**
- SUPPLEMENTAL SIGNAGE AND PAINT MARKINGS AS PER LATEST EDITION OF THE CITY OF EDMONTON MANUAL FOR PAVEMENT MARKING DESIGN, AND THE MANUAL FOR UNIFORM TRAFFIC CONTROL DEVICES OF CANADA. MARKINGS TO BE CONFIRMED BY ENGINEER
 - MAY REQUIRE CHANGES TO DRAINAGE DESIGN

- NOTE:**
- WIDTH OF RAISED CROSSING TO BE MINIMUM 4.0m OR MATCH WIDTH OF CROSSWALK/SIDEWALK, SHARED PATHWAY, BIKE PATH AND/OR RAISED PROTECTED BIKE LANE, WHICHEVER IS GREATER
 - SEE SECTION 3.6.4.3 FOR RAMP LENGTH AND GRADE BREAK REQUIREMENTS

**ALL DIMENSIONS
IN MILLIMETRES UNLESS
OTHERWISE NOTED**

STANDARD DRAWING

CONCRETE DETAILS - RAISED CROSSING

DATE APPROVED: **2025**
SCALE: **N.T.S.**

DRAWN BY: **FR**
CHECKED BY: **JN**

APPROVED:

DRAWING NUMBER: **3810**

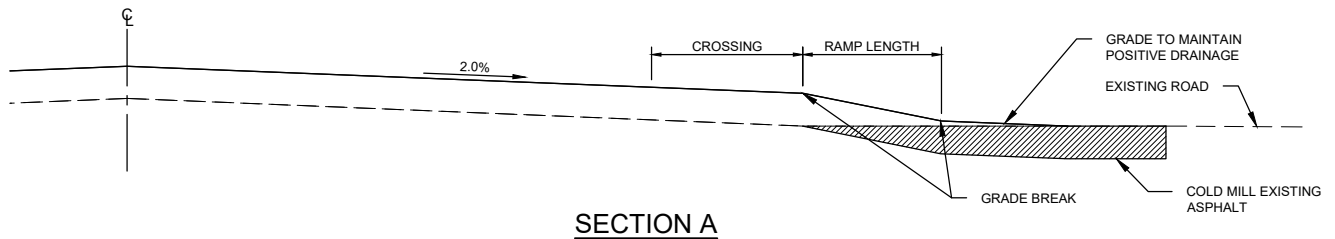
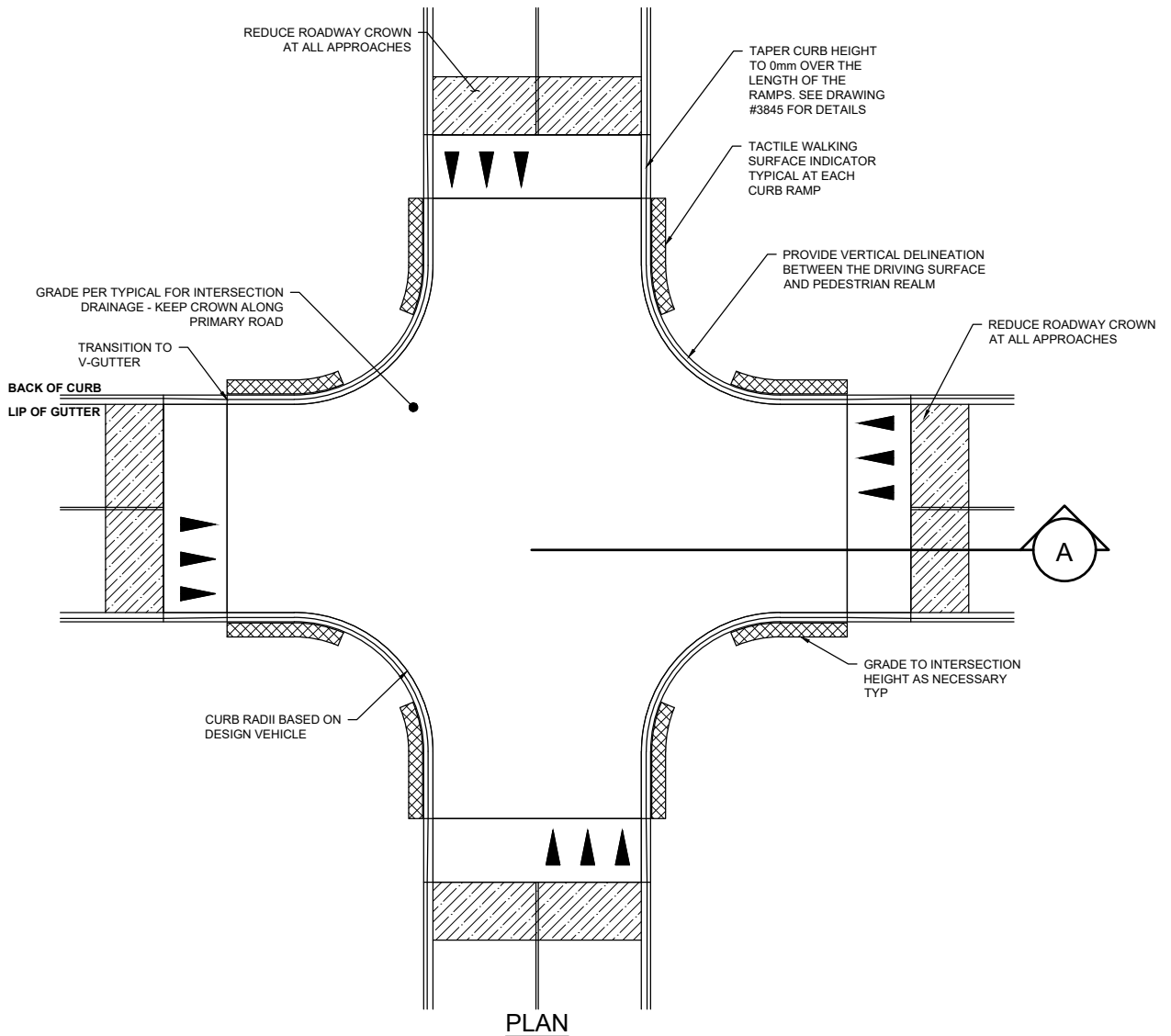

NOTES:

- SUPPLEMENTAL SIGNAGE AND PAINT MARKINGS AS PER LATEST EDITION OF THE CITY OF EDMONTON MANUAL FOR PAVEMENT MARKING DESIGN, AND THE MANUAL FOR UNIFORM TRAFFIC CONTROL DEVICES OF CANADA. MARKINGS TO BE CONFIRMED BY ENGINEER
- MAY REQUIRE CHANGES TO DRAINAGE DESIGN

NOTE:

1. SEE SECTION 2.3 FOR RAMP LENGTH AND GRADE BREAK REQUIREMENTS

ALL DIMENSIONS IN MILLIMETRES UNLESS OTHERWISE NOTED

RAISED INTERSECTION - ASPHALT



STANDARD DRAWING

DATE APPROVED: **2025**

DRAWN BY: **FR**

APPROVED: *[Signature]*

DRAWING NUMBER: **3815**

SCALE: **N.T.S.**

CHECKED BY: **JN**

NOTE:

- TRANSITION ROLLED FACE CURBS TO STRAIGHT FACE CURBS IN THE CROWN TRANSITION ZONE OVER A MINIMUM LENGTH OF 3.0m. STRAIGHT FACE CURB SHOULD BE ACHIEVED A MINIMUM 1.5 - 2.0m BEFORE THE RAISED INTERSECTION RAMP. THIS FACILITATES THE DEVELOPMENT OF RAMP GRADE BREAKS AND INCREASED VISIBILITY OF SIDEWALK USERS
- CROWN TRANSITION ZONE LENGTH WILL VARY WITH ROAD WIDTH AND GRADING DESIGN

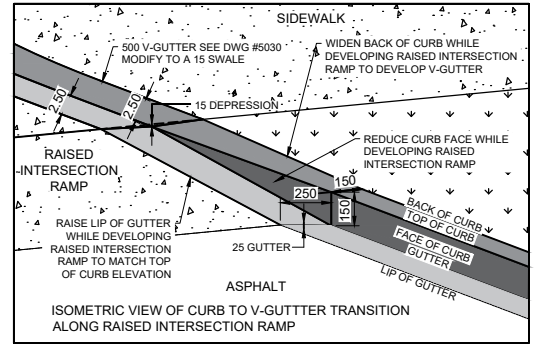

GRADE PER TYPICAL FOR INTERSECTION DRAINAGE - FOLLOW GRADE DESIGN FOR ROAD CROWN

DETECTABLE WARNING SURFACE INDICATOR. INSTALL 3 UNITS FOR FOR TYPICAL 1.8m SIDEWALKS. WIDEN TO MATCH FACILITY WIDTH AS REQUIRED.

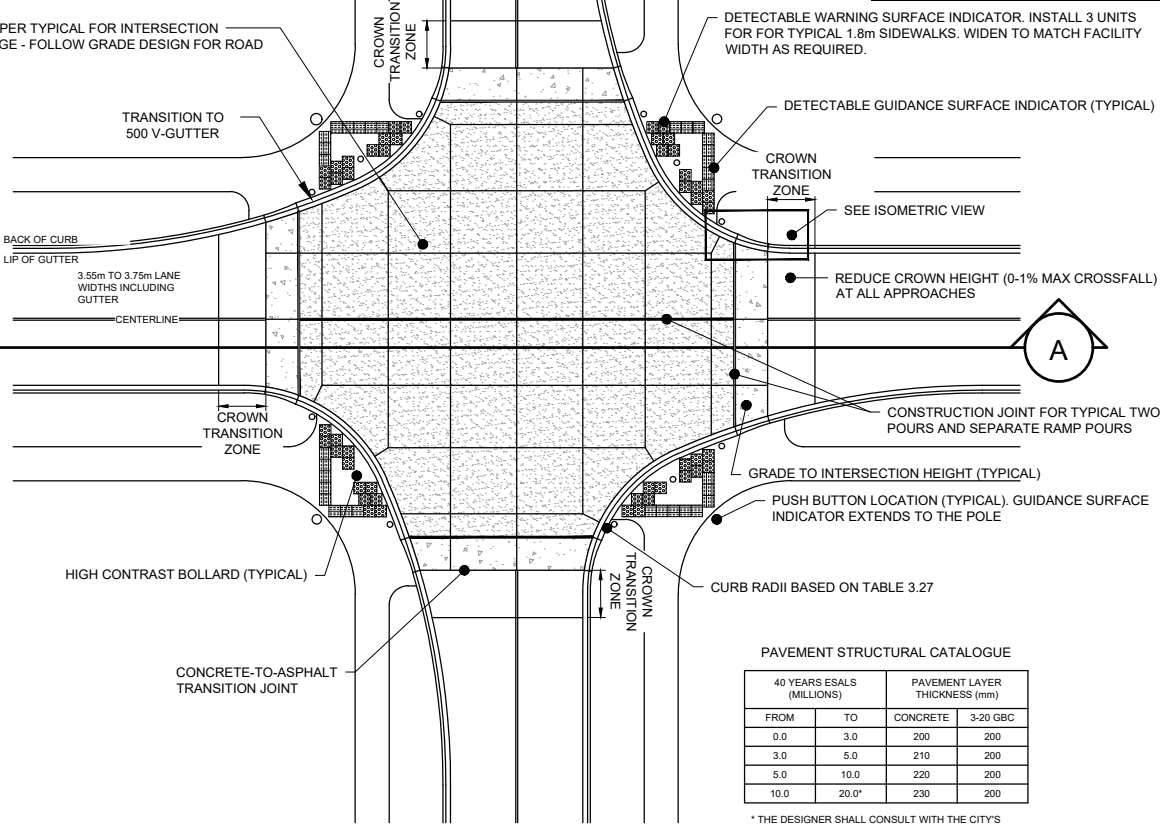

PAVEMENT STRUCTURAL CATALOGUE

40 YEARS ESALS (MILLIONS)		PAVEMENT LAYER THICKNESS (mm)	
FROM	TO	CONCRETE	3-20 GBC
0.0	3.0	200	200
3.0	5.0	210	200
5.0	10.0	220	200
10.0	20.0*	230	200

* THE DESIGNER SHALL CONSULT WITH THE CITY'S INTEGRATED INFRASTRUCTURE SERVICES BRANCH TO CONFIRM THAT RAISED INTERSECTIONS IS APPROPRIATE FOR SUCH LOCATIONS WITH HIGH TRAFFIC VOLUME

PLAN

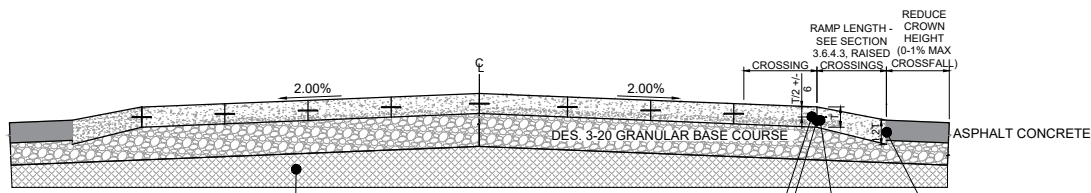

CONSTRUCT ON PREPARED SUBGRADE. INCLUDE GEOTEXTILE FABRIC AND/OR GRID AS APPROPRIATE

SECTION A

NOTE:

- SUPPLEMENTAL SIGNAGE AND PAINT MARKINGS AS PER LATEST EDITION OF THE CITY OF EDMONTON MANUAL FOR PAVEMENT MARKING DESIGN, AND THE MANUAL FOR UNIFORM TRAFFIC CONTROL DEVICES OF MARKINGS TO BE CONFIRMED BY ENGINEER
- MAY REQUIRE CHANGES TO DRAINAGE DESIGN
- WEAK SUBGRADE SOILS WITH LESS THAN 30 MPa SHALL BE TREATED WITH METHODOLOGIES DETERMINED THROUGH GEOTECHNICAL INVESTIGATION TO IMPROVE THE SUBGRADE
- THE DESIGN ESALS SHALL BE CALCULATED AS A SUM OF THE DESIGN ESALS OF THE INTERSECTING ROADS
- THE DESIGN ESALS CALCULATIONS SHALL BE SHOWN IN THE DESIGN REPORT
- SEE DRAWING NO. 5521 FOR TACTILE WARNING SURFACE INDICATOR LAYOUT

ALL DIMENSIONS IN MILLIMETRES UNLESS OTHERWISE NOTED

RAISED INTERSECTION - CONCRETE



STANDARD DRAWING

DATE APPROVED: **2025**

DRAWN BY: **TN / EM**

APPROVED: *[Signature]*

DRAWING NUMBER: **3820**

SCALE: **N.T.S.**

CHECKED BY: **CF / MB / JP**

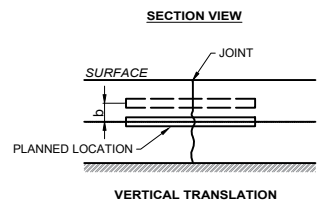
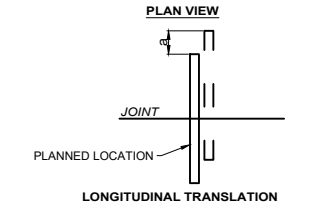
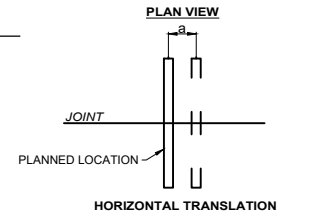
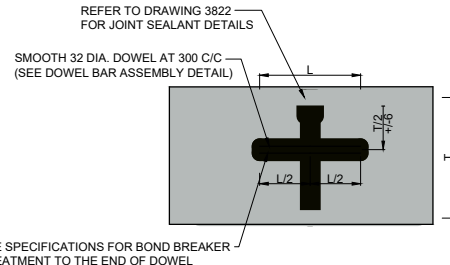
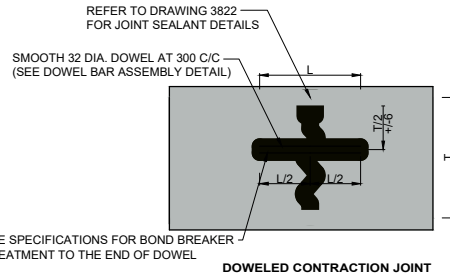
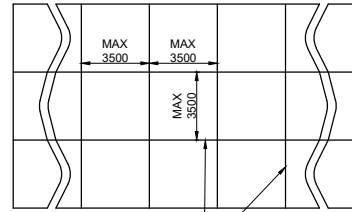
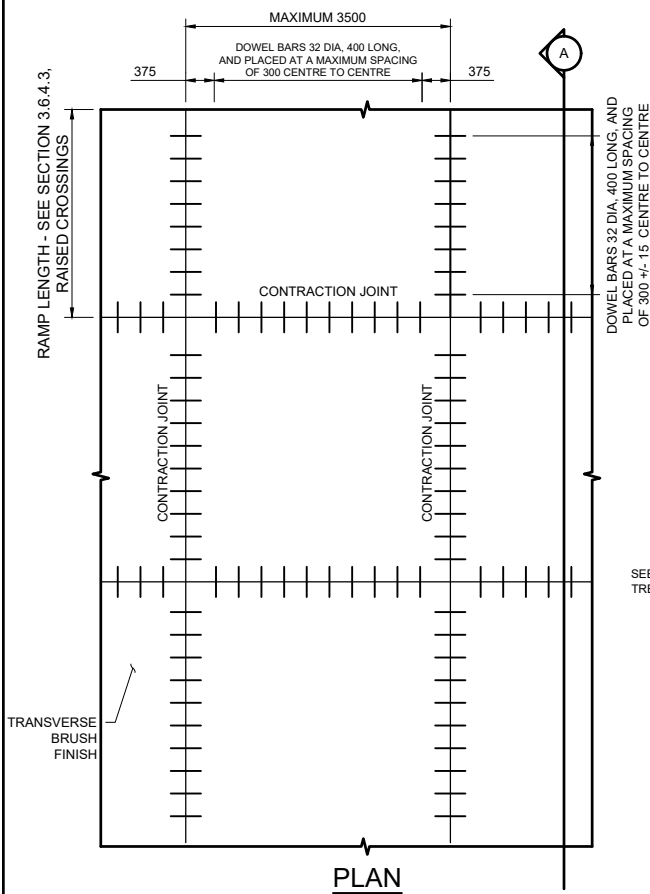

- a ≤ 15
- b ≤ 6 (above or below the planned location)
- c ≤ 5 / 400

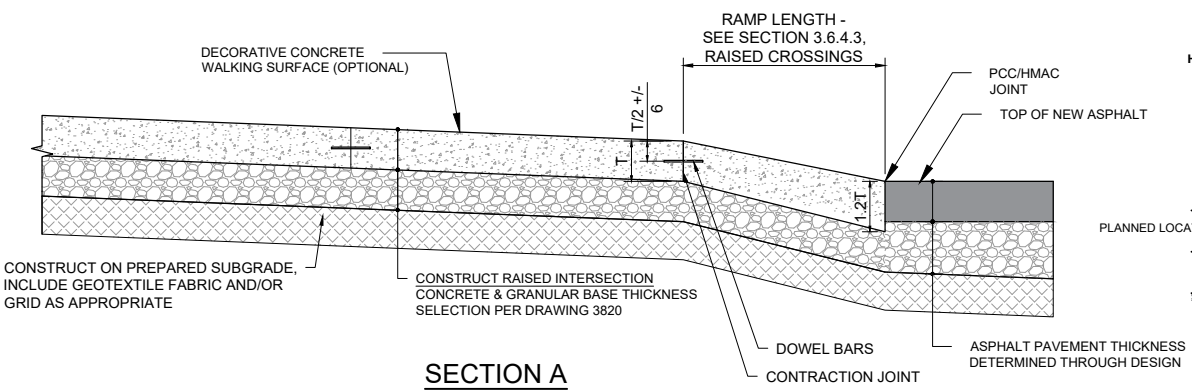
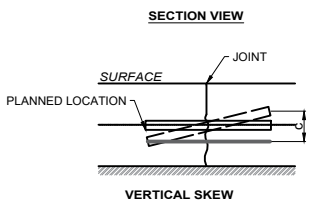
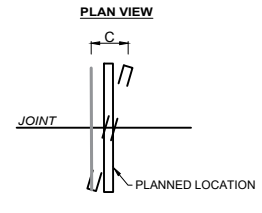

GENERAL JOINTING INFORMATION FOR CONCRETE RAISED INTERSECTION:

- THE CONTRACTION JOINTS SHALL BE PROVIDED IN THE TRANSVERSE AND LONGITUDINAL DIRECTIONS WITH A MAXIMUM SPACING OF 3 METERS. THE JOINTS SHALL BE LAID OUT TO ALIGN WITH LANE EDGES OR BETWEEN THE WHEELPATHS (AVOID JOINTS ON OR NEAR WHEELPATHS).
- THE CONSTRUCTION JOINTS SHALL BE PLACED IF ABUTTING CONSTRUCTION IS PLACED AT DIFFERENT TIMES OR IF THE DISCHARGE INTERVAL BETWEEN SUCCESSIVE CONCRETE LOADS IS GREATER THAN 30 MINUTES.
- THE CONTRACTION AND CONSTRUCTION JOINTS SHALL BE DOWELED, AS SHOWN IN THIS DRAWING. THE DOWEL BARS SHALL BE A MINIMUM OF 32mm IN DIAMETER, 400mm LONG, AND PLACED AT A MAXIMUM SPACING OF 300mm ON-CENTRE, TOLERANCES PROVIDED ABOVE.
- THE INTERSECTION JOINT LAYOUT SHALL BE PREPARED AND SUBMITTED TO THE CITY FOR APPROVAL. AMERICAN CONCRETE PAVEMENT ASSOCIATION (ACPA). 2007a. *Intersection Joint Layout*. IS006 MAY BE CONSULTED IN THE JOINT LAYOUT DEVELOPMENT.

ALL DIMENSIONS IN MILLIMETRES UNLESS OTHERWISE NOTED

STANDARD DRAWING

RAISED INTERSECTION - CONCRETE JOINT DETAILS

DATE APPROVED: 2025	DRAWN BY: TN / EM	APPROVED: 	DRAWING NUMBER: 3821
SCALE: N.T.S.	CHECKED BY: CF / MB / JP		

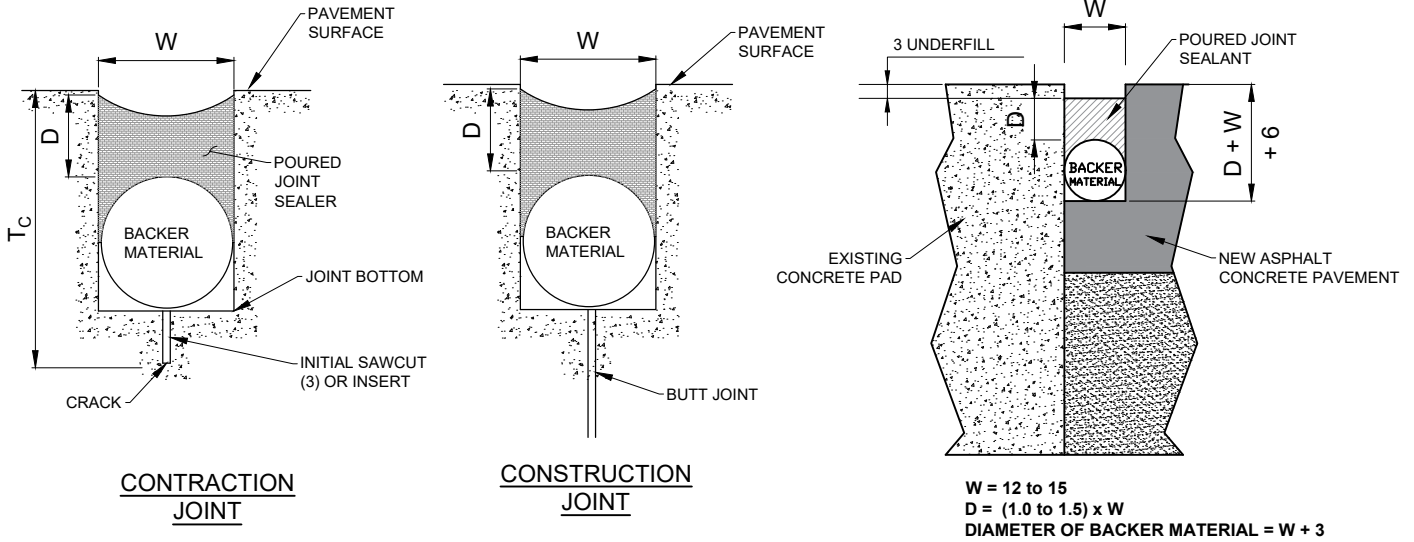

W = WIDTH OF SEALANT RESERVOIR, MINIMUM 6
 D = DEPTH OF SEALANT RESERVOIR, (1.0 to 1.5) x W
 T_c = DEPTH OF INITIAL SAW-CUT CONTRACTION JOINT,
 1/4 SLAB THICKNESS (FOR SLABS WITH GRANULAR BASE).
 BACKER MATERIAL SHALL BE 25% LARGER IN DIAMETER THAN THE ACTUAL JOINT WIDTH.

HOT-POURED JOINT SEALANT DETAIL

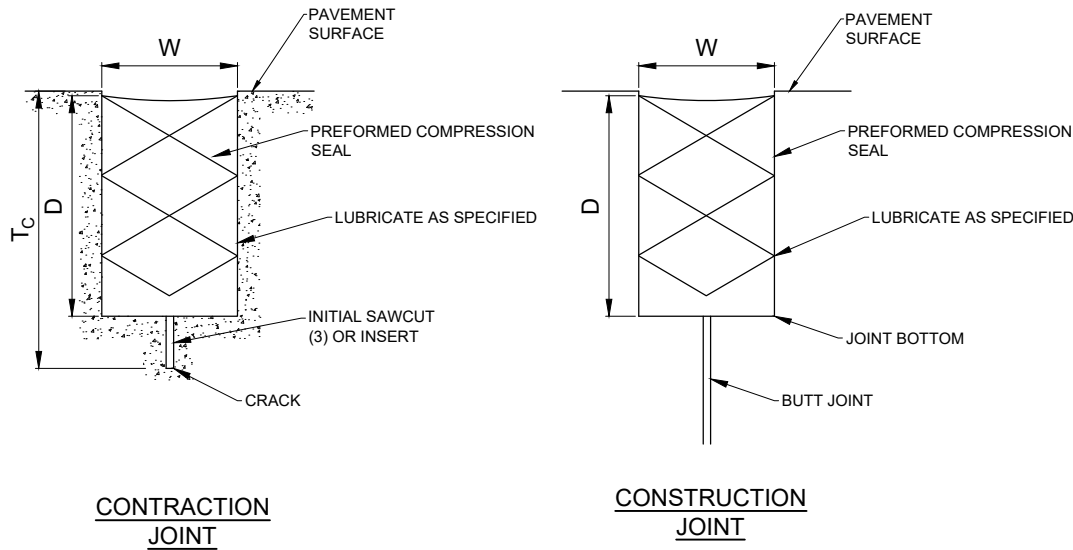

W = PER THE SEALANT MANUFACTURER'S RECOMMENDATION
 D = PER THE SEALANT MANUFACTURER'S RECOMMENDATION
 T_c = PER THE SEALANT MANUFACTURER'S RECOMMENDATION,
 BUT NO LESS THAN 1/4 SLAB THICKNESS (FOR SLABS WITH GRANULAR BASE).

ALL DIMENSIONS IN MILLIMETRES UNLESS OTHERWISE NOTED

PREFORMED JOINT SEALANT DETAIL

STANDARD DRAWING

RAISED INTERSECTION - CONCRETE JOINT SEALANT DETAILS

DATE APPROVED: **2025**

SCALE: **N.T.S.**

DRAWN BY: **TN / EM**

CHECKED BY: **CF / MB / JP**

APPROVED: *[Signature]*

DRAWING NUMBER: **3822**

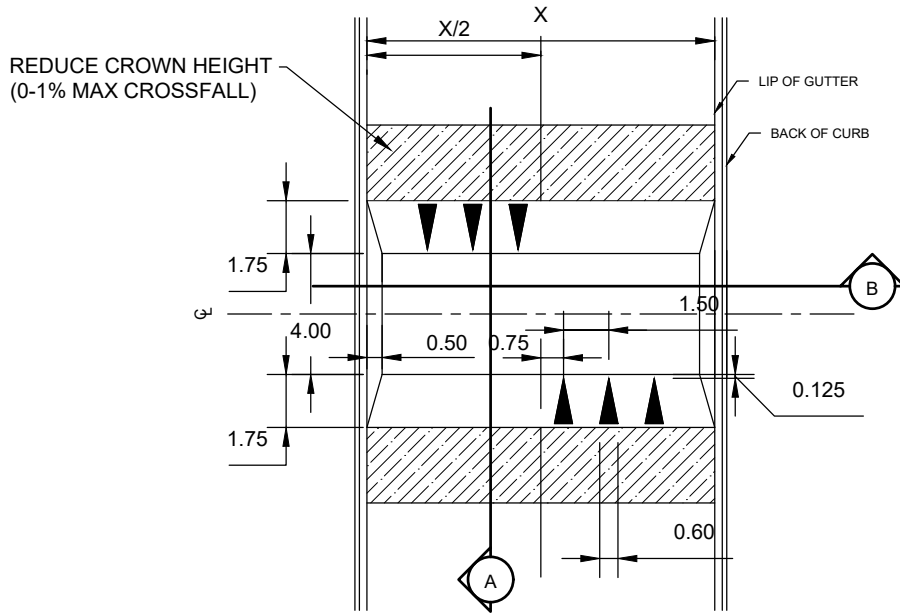

PLAN

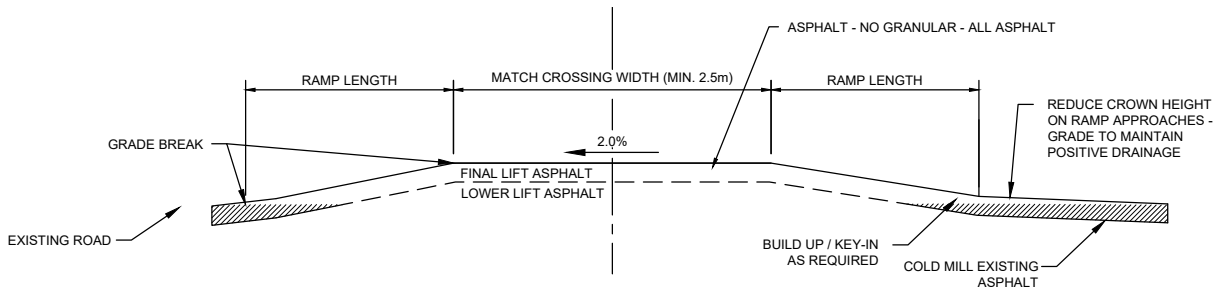

SECTION A

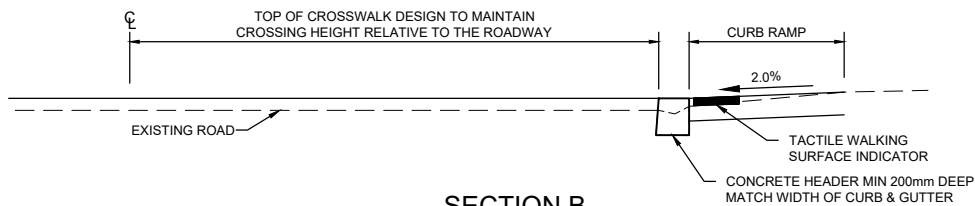

SECTION B

- NOTES:
- SUPPLEMENTAL SIGNAGE AND PAINT MARKINGS AS PER LATEST EDITION OF THE CITY OF EDMONTON MANUAL FOR PAVEMENT MARKING DESIGN, AND THE MANUAL FOR UNIFORM TRAFFIC CONTROL DEVICES OF CANADA. MARKINGS TO BE CONFIRMED BY ENGINEER
 - SEE SECTION 2.3 FOR RAMP LENGTH AND GRADE BREAK REQUIREMENTS
 - TOP WIDTH CAN BE REDUCED TO 3.0m IN CONSTRAINED LOCATIONS WITHOUT BUS SERVICE
 - MAY REQUIRE CHANGES TO DRAINAGE DESIGN

**ALL DIMENSIONS
IN METRES UNLESS
OTHERWISE NOTED**



RAISED MID BLOCK CROSSING - ASPHALT

DATE APPROVED: **2025**
SCALE: **N.T.S.**

DRAWN BY: **FR**
CHECKED BY: **JN**

APPROVED: *[Signature]*

DRAWING NUMBER: **3830**

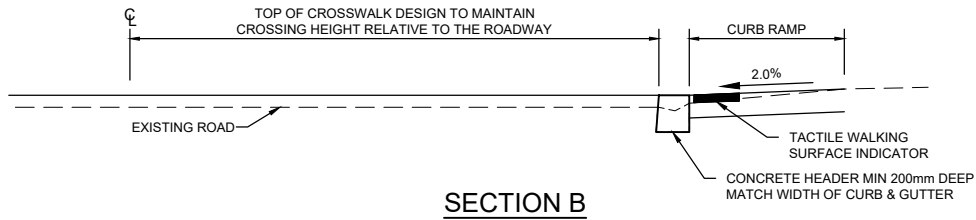
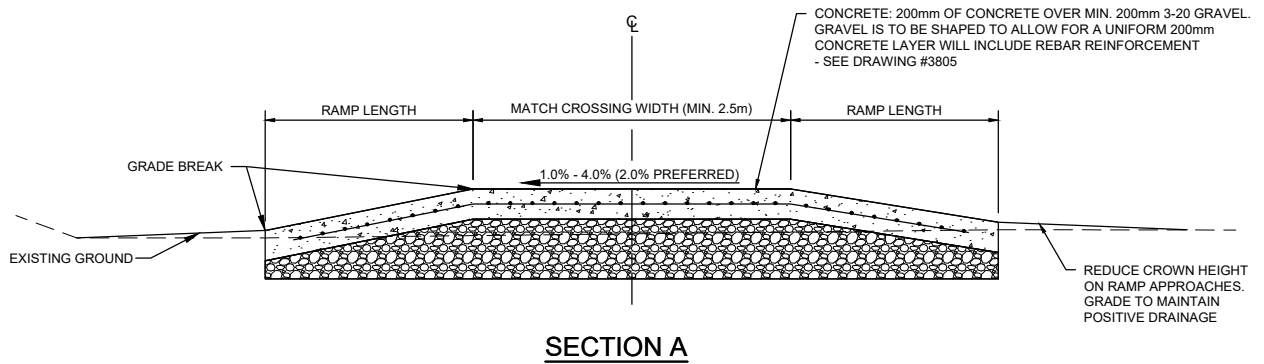
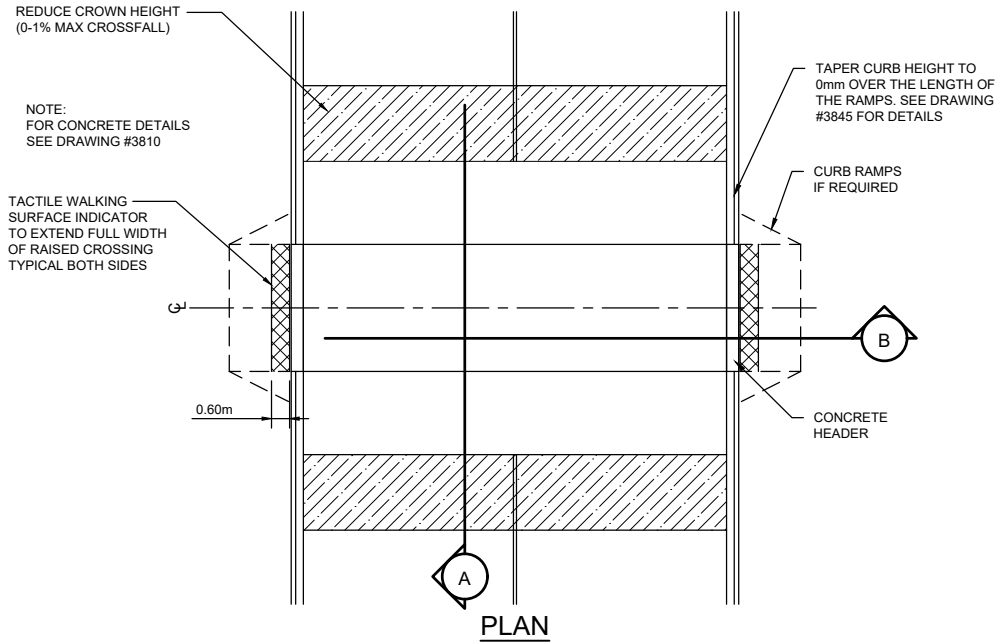

- NOTES:
- SUPPLEMENTAL SIGNAGE AND PAINT MARKINGS AS PER LATEST EDITION OF THE CITY OF EDMONTON MANUAL FOR PAVEMENT MARKING DESIGN, AND THE MANUAL FOR UNIFORM TRAFFIC CONTROL DEVICES OF CANADA. MARKINGS TO BE CONFIRMED BY ENGINEER
 - MAY REQUIRE CHANGES TO DRAINAGE DESIGN

NOTE:
1. SEE SECTION 2.3 FOR RAMP LENGTH AND GRADE BREAK REQUIREMENTS

**ALL DIMENSIONS
IN METRES UNLESS
OTHERWISE NOTED**

STANDARD DRAWING

RAISED MID BLOCK CROSSING - CONCRETE

DATE APPROVED: 2025	DRAWN BY: FR	APPROVED: 	DRAWING NUMBER: 3835
SCALE: N.T.S.	CHECKED BY: JN		

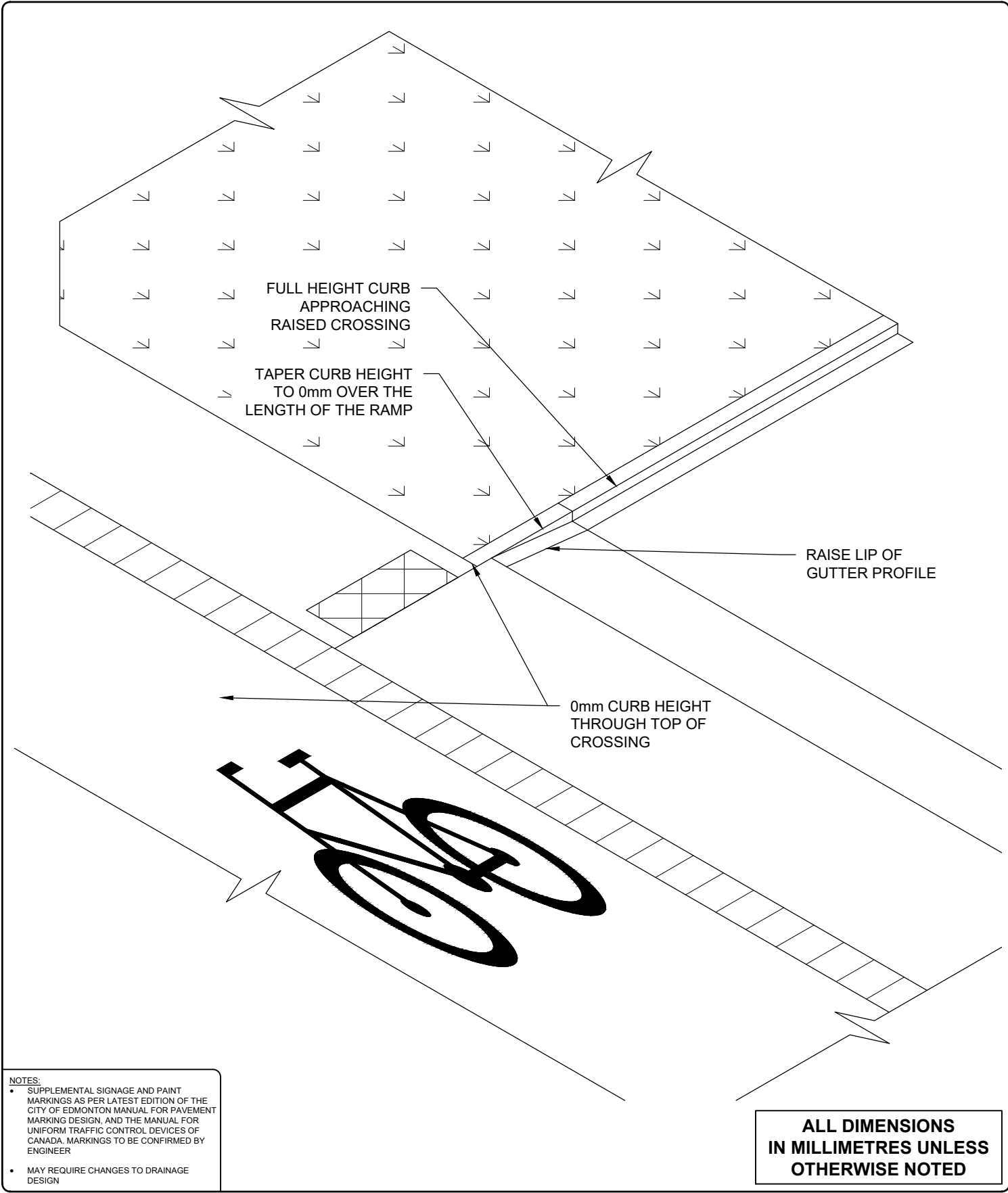

STANDARD DRAWING

CONTINUOUS CROSSING ISOMETRIC DETAIL

DATE APPROVED: **2025**

SCALE: **N.T.S.**

DRAWN BY: **FR**

CHECKED BY: **JN**

APPROVED: 

DRAWING NUMBER: **3845**

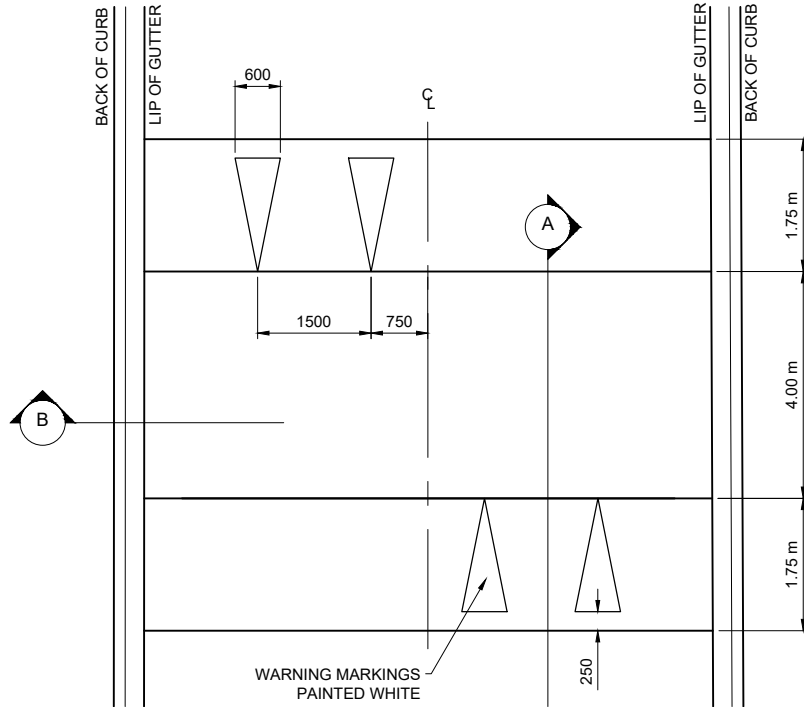

PLAN

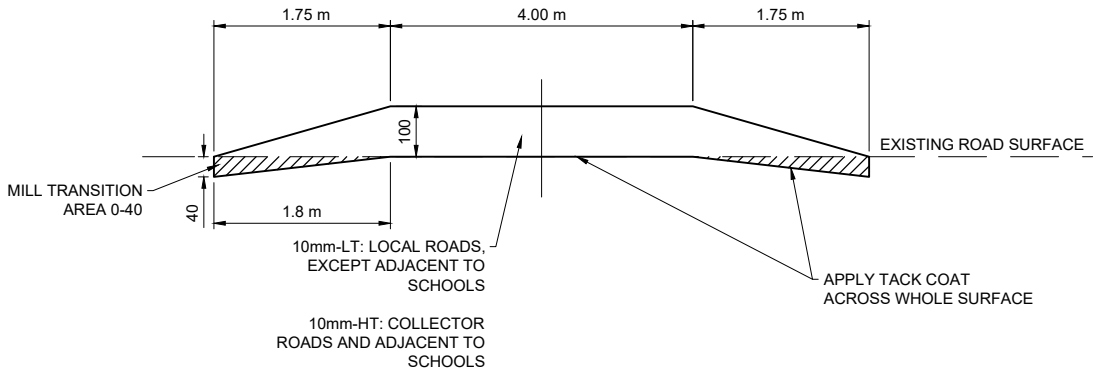

SECTION A

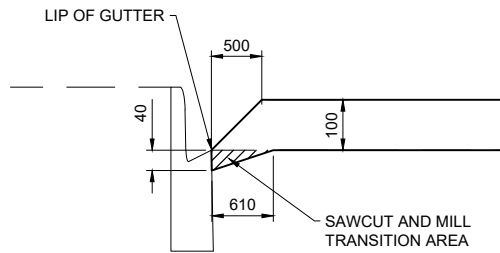

SECTION B

- NOTES:
- SUPPLEMENTAL SIGNAGE AND PAINT MARKINGS AS PER LATEST EDITION OF THE CITY OF EDMONTON MANUAL FOR PAVEMENT MARKING DESIGN, AND THE MANUAL FOR UNIFORM TRAFFIC CONTROL DEVICES OF CANADA. MARKINGS TO BE CONFIRMED BY ENGINEER
 - MAY REQUIRE CHANGES TO DRAINAGE DESIGN

ALL DIMENSIONS IN METRES UNLESS OTHERWISE NOTED

STANDARD DRAWING

4.00m ASPHALT SPEED TABLE

DATE APPROVED: **2025**
SCALE: **N.T.S.**

DRAWN BY: **FR**
CHECKED BY: **JN**

APPROVED: *[Signature]*

DRAWING NUMBER: **3850**

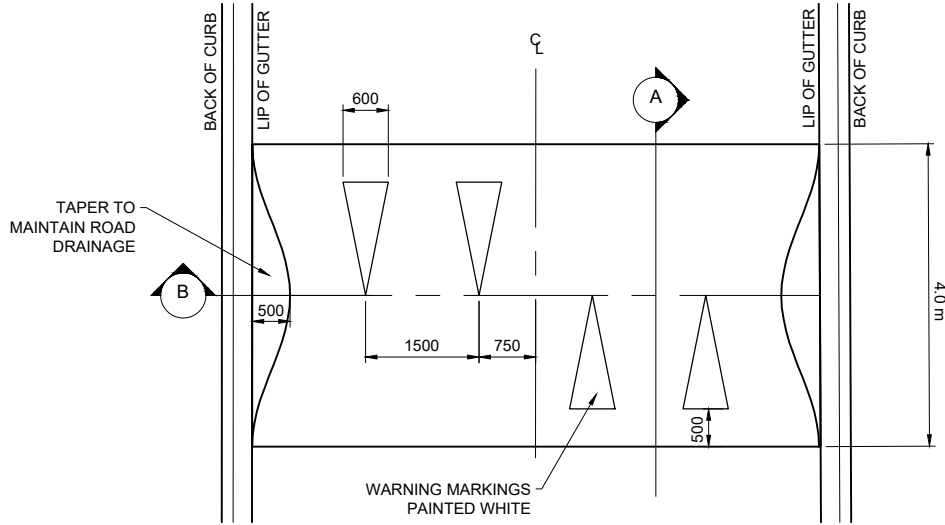

PLAN

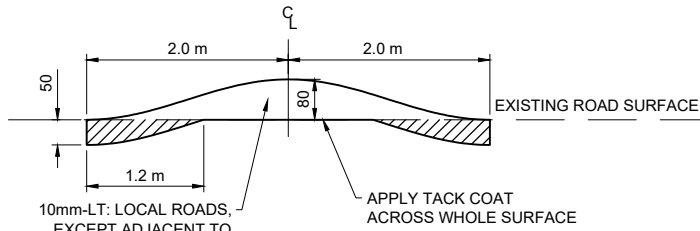

10mm-LT: LOCAL ROADS, EXCEPT ADJACENT TO SCHOOLS

10mm-HT: COLLECTOR ROADS AND ADJACENT TO SCHOOLS

APPLY TACK COAT ACROSS WHOLE SURFACE

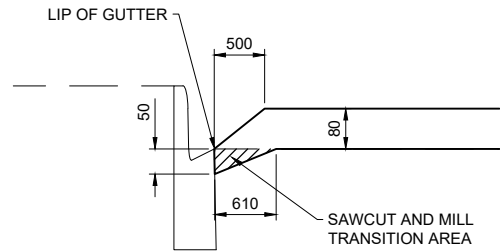

SECTION A

SECTION B

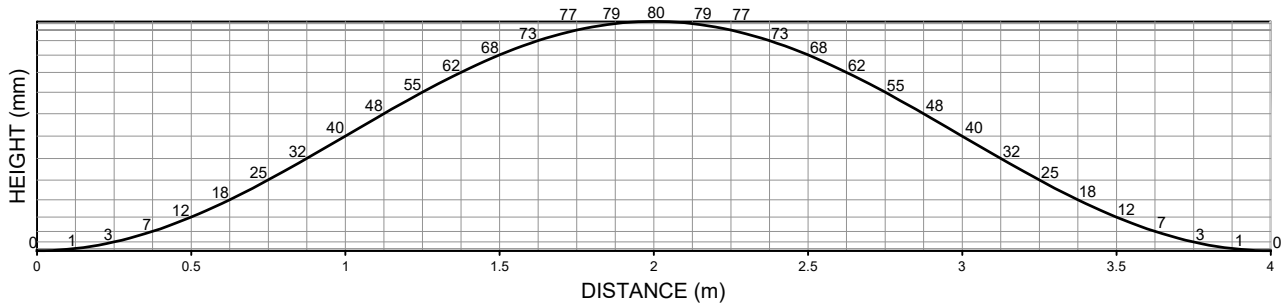

Distance (m)	0.000	0.125	0.250	0.375	0.500	0.625	0.750	0.875	1.000	1.125	1.250	1.375	1.500	1.625	1.750	1.875	2.000
Height (mm)	0	1	3	7	12	18	25	32	40	48	55	62	68	73	77	79	80

SINUSOIDAL SPEED HUMP DEVELOPMENT

- NOTES:
- SUPPLEMENTAL SIGNAGE AND PAINT MARKINGS AS PER LATEST EDITION OF THE CITY OF EDMONTON MANUAL FOR PAVEMENT MARKING DESIGN, AND THE MANUAL FOR UNIFORM TRAFFIC CONTROL DEVICES OF CANADA. MARKINGS TO BE CONFIRMED BY ENGINEER
 - MAY REQUIRE CHANGES TO DRAINAGE DESIGN

ALL DIMENSIONS IN MILLIMETRES UNLESS OTHERWISE NOTED

STANDARD DRAWING

4.0m ASPHALT SPEED HUMP

DATE APPROVED: 2025	DRAWN BY: FR	APPROVED: 	DRAWING NUMBER: 3855
SCALE: N.T.S.	CHECKED BY: JN		

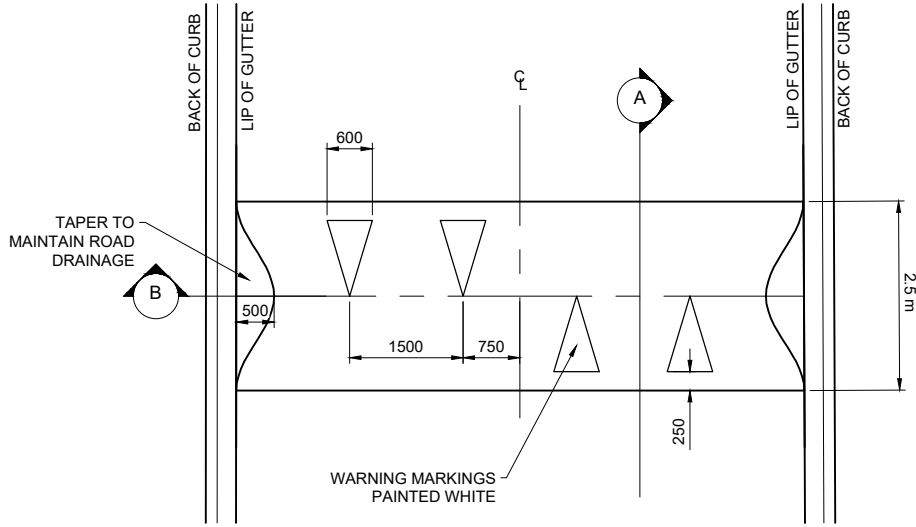

PLAN

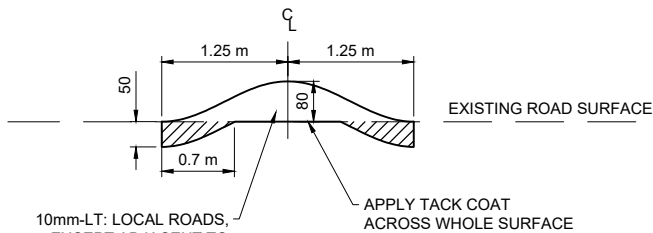

10mm-LT: LOCAL ROADS, EXCEPT ADJACENT TO SCHOOLS

10mm-HT: COLLECTOR ROADS AND ADJACENT TO SCHOOLS

SECTION A

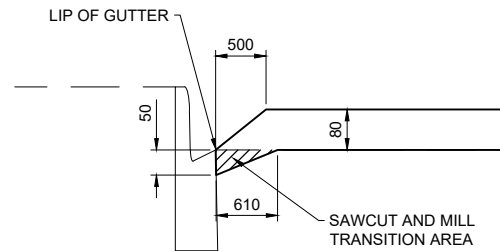

SECTION B

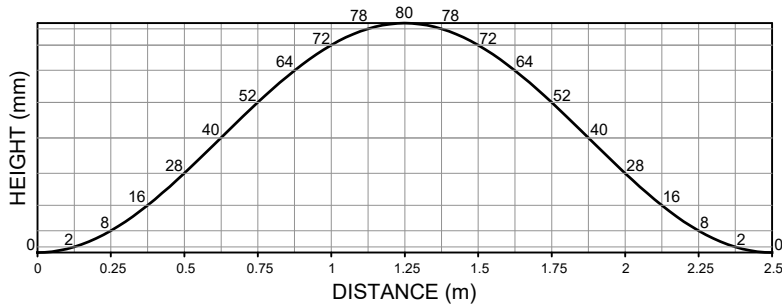

Distance (m)	0.000	0.125	0.250	0.375	0.500	0.625	0.750	0.875	1.000	1.125	1.250
Height (mm)	0	2	8	16	28	40	52	64	72	78	80

SINUSOIDAL SPEED HUMP DEVELOPMENT

- NOTES:
- SUPPLEMENTAL SIGNAGE AND PAINT MARKINGS AS PER LATEST EDITION OF THE CITY OF EDMONTON MANUAL FOR PAVEMENT MARKING DESIGN, AND THE MANUAL FOR UNIFORM TRAFFIC CONTROL DEVICES OF CANADA. MARKINGS TO BE CONFIRMED BY ENGINEER
 - MAY REQUIRE CHANGES TO DRAINAGE DESIGN

ALL DIMENSIONS IN MILLIMETRES UNLESS OTHERWISE NOTED

STANDARD DRAWING

2.5m ASPHALT SPEED HUMP

DATE APPROVED: **2025**

DRAWN BY: **FR**

APPROVED: *[Signature]*

DRAWING NUMBER: **3860**

SCALE: **N.T.S.**

CHECKED BY: **JN**

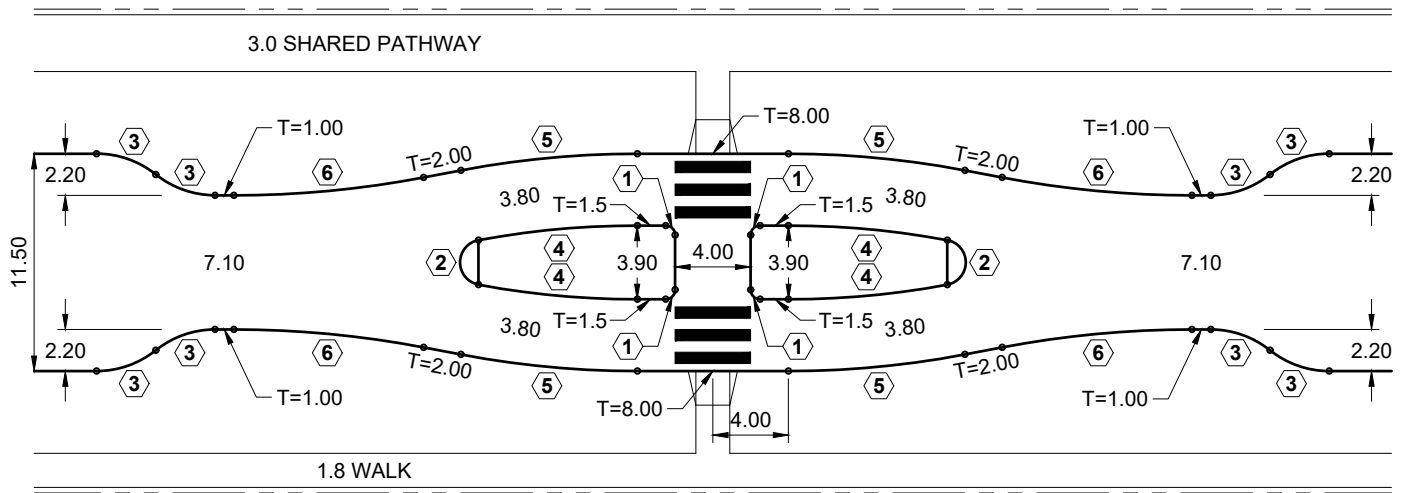

ID	R	Δ	L
1	0.50	90°00'00"	0.785
2	1.20	159°02'58"	3.331
3	5.00	38°44'22"	3.381
4	46.20	10°28'31"	8.447
5	50.00	10°45'51"	9.393
6	53.80	10°45'51"	10.107

NOTE:
1. ALL DIMENSIONS TO FACE OF CURB UNLESS OTHERWISE NOTED.

**ALL DIMENSIONS
IN METRES UNLESS
OTHERWISE NOTED**



MID-BLOCK COLLECTOR TWO STAGE CROSSING

DATE APPROVED: **2025**
SCALE: **N.T.S.**

DRAWN BY: **FR**
CHECKED BY: **JN**

APPROVED:

DRAWING NUMBER: **3870**

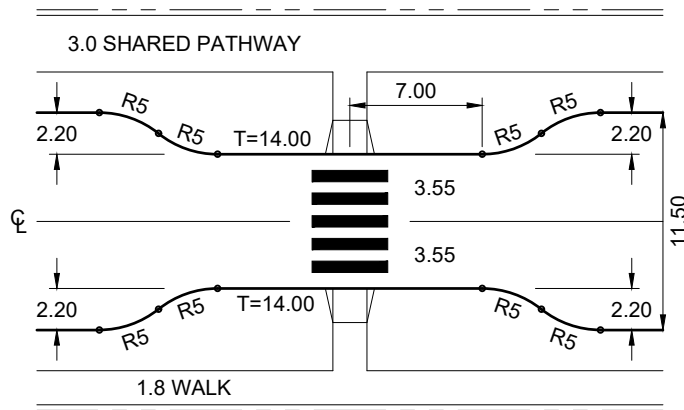

- NOTE:
1. ALL DIMENSIONS TO FACE OF CURB UNLESS OTHERWISE NOTED.

**ALL DIMENSIONS
IN METRES UNLESS
OTHERWISE NOTED**

STANDARD DRAWING

MID-BLOCK COLLECTOR CROSSING BULB

DATE APPROVED: **2025**

DRAWN BY: **FR**

APPROVED: *[Signature]*

DRAWING NUMBER: **3871**

SCALE: **N.T.S.**

CHECKED BY: **JN**

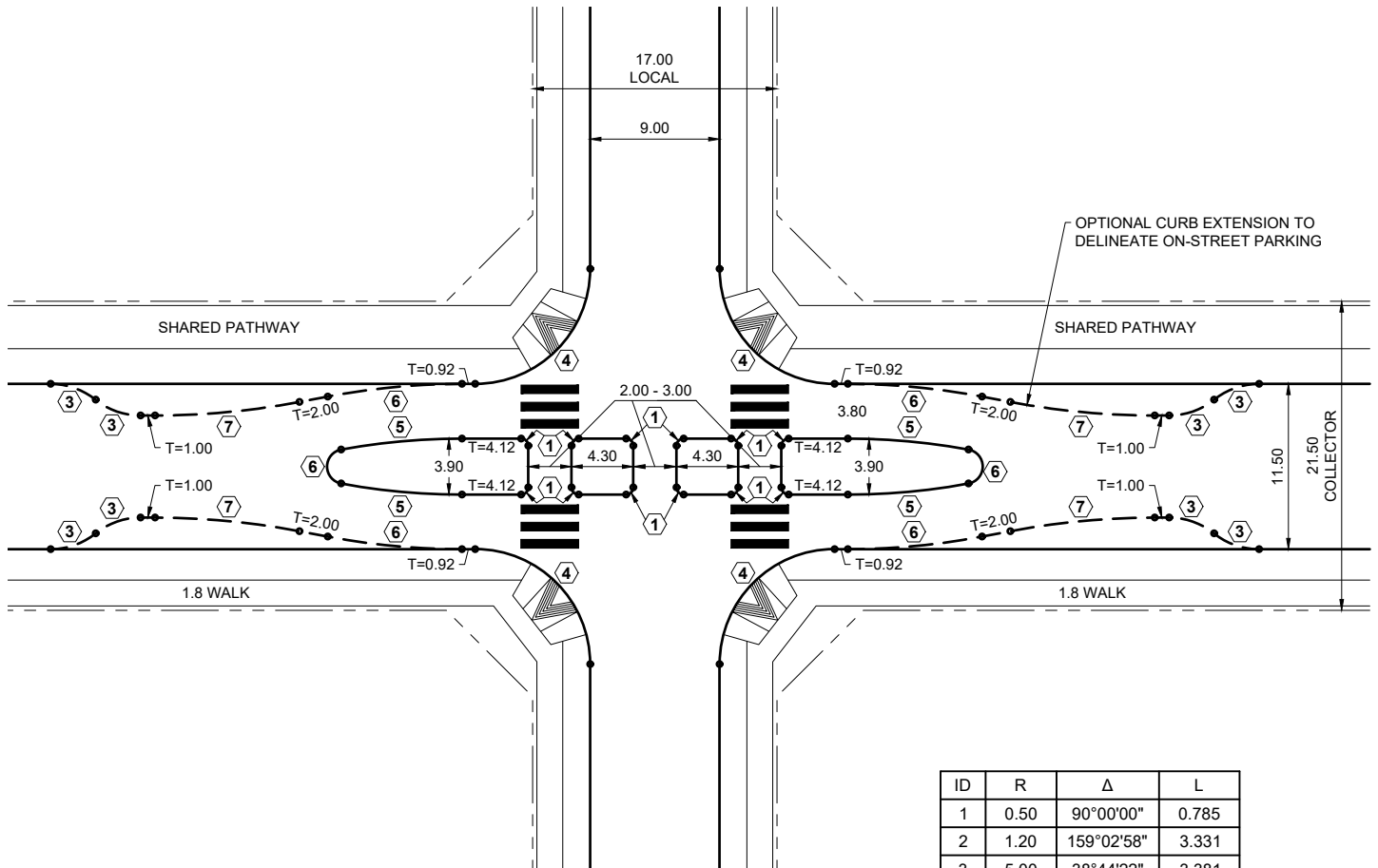

ID	R	Δ	L
1	0.50	90°00'00"	0.785
2	1.20	159°02'58"	3.331
3	5.00	38°44'22"	3.381
4	8.00	90°00'00"	12.566
5	46.20	10°28'31"	8.447
6	50.00	10°45'51"	9.393
7	53.80	10°45'51"	10.107

**ALL DIMENSIONS
IN METRES UNLESS
OTHERWISE NOTED**



LOCAL STREET BIKEWAY MEDIAN DIVERTER

DATE APPROVED: **2025**
SCALE: **N.T.S.**

DRAWN BY: **FR**
CHECKED BY: **JN**

APPROVED: *[Signature]*

DRAWING NUMBER: **3875**

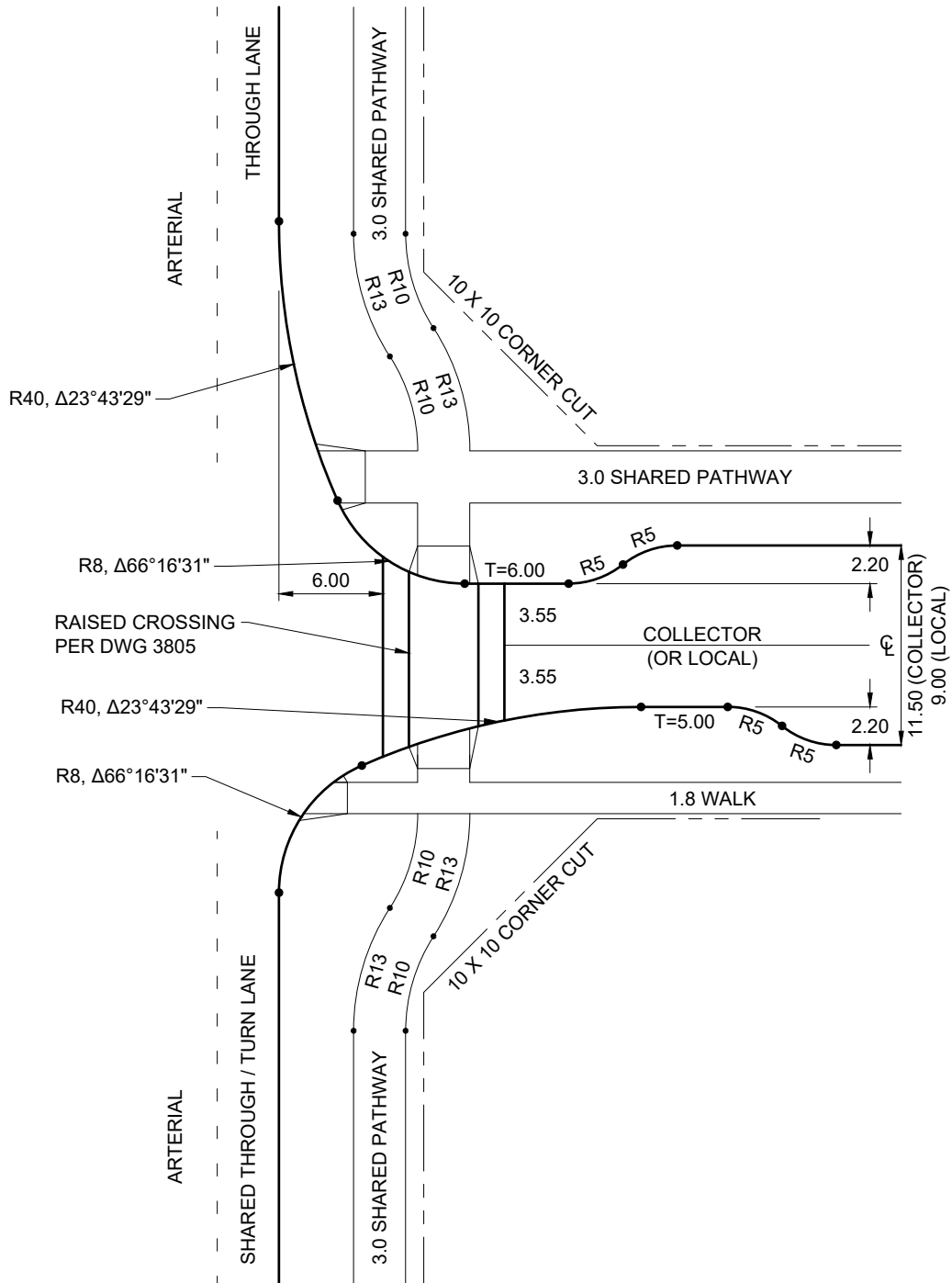

NOTE:

- 1. ALL DIMENSIONS TO FACE OF CURB UNLESS OTHERWISE NOTED. DIMENSIONS ASSUME NO INTERSECTION SKEW OR OFFSET

**ALL DIMENSIONS
IN METRES UNLESS
OTHERWISE NOTED**



STANDARD DRAWING

**BEND OUT GATEWAY INTERSECTION TREATMENT
(NO RIGHT TURN BAY)**

DATE APPROVED: **2025**
SCALE: **N.T.S.**

DRAWN BY: **FR**
CHECKED BY: **JN**

APPROVED: 

DRAWING NUMBER: **3880**

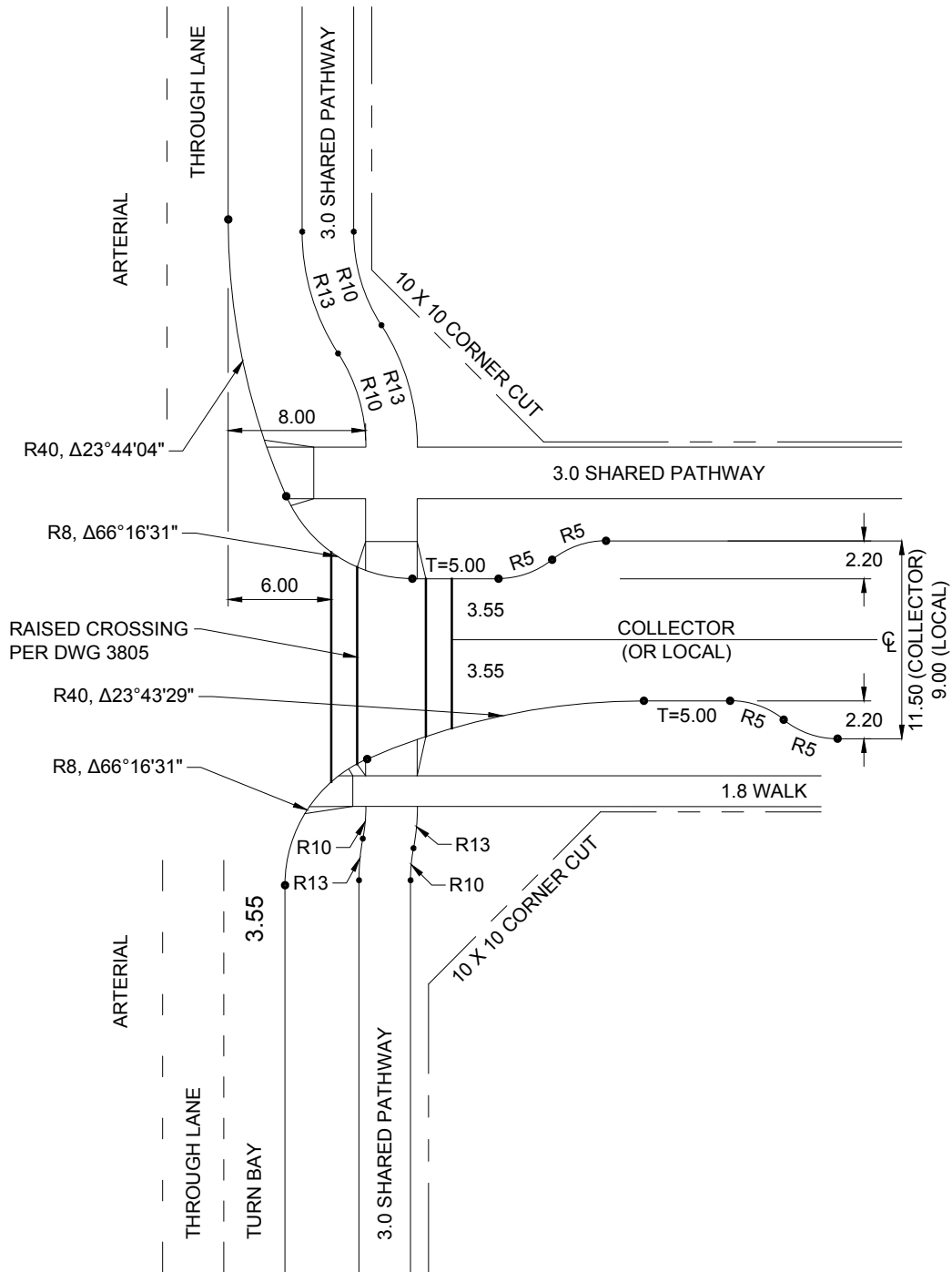

NOTE:

1. ALL DIMENSIONS TO FACE OF CURB UNLESS OTHERWISE NOTED. DIMENSIONS ASSUME NO INTERSECTION SKEW OR OFFSET.

**ALL DIMENSIONS
IN METRES UNLESS
OTHERWISE NOTED**



**BEND OUT GATEWAY INTERSECTION TREATMENT
(WITH RIGHT TURN BAY)**

DATE APPROVED: **2025**
SCALE: **N.T.S.**

DRAWN BY: **FR**
CHECKED BY: **JN**

APPROVED: *[Signature]*

DRAWING NUMBER: **3881**

COLLECTOR / COLLECTOR BULB DETAIL

COE BUS TURNING MOVEMENT

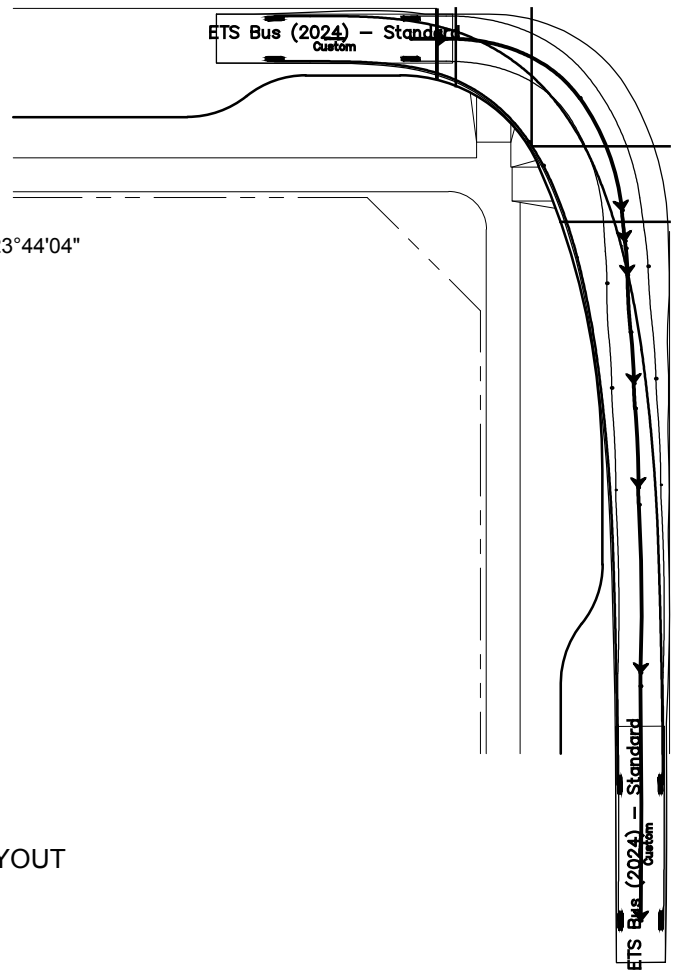
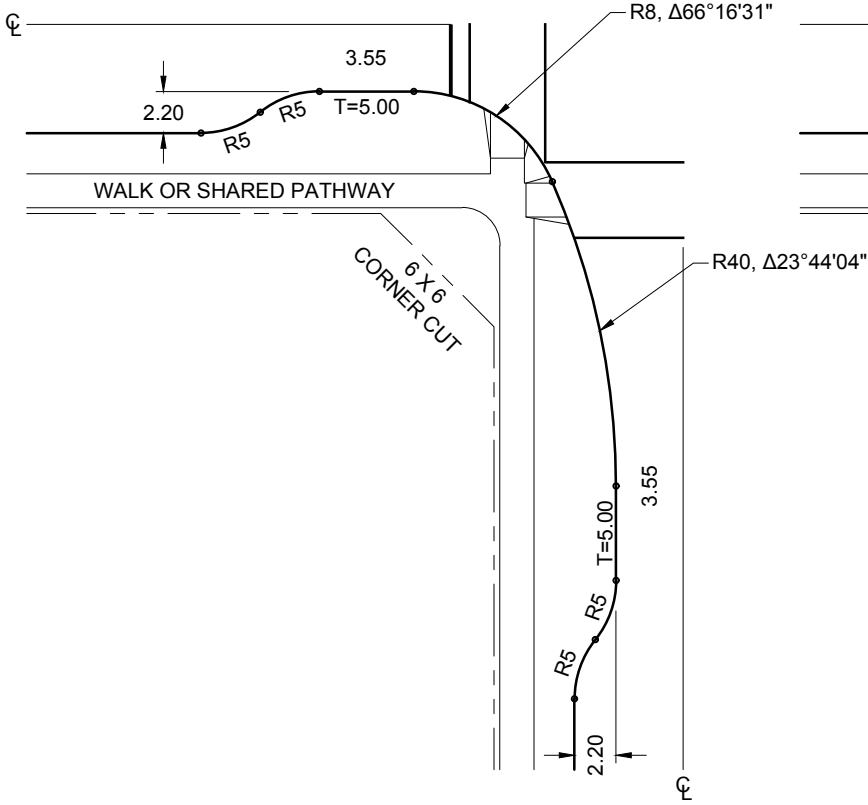

INSET - 4 LEG LAYOUT

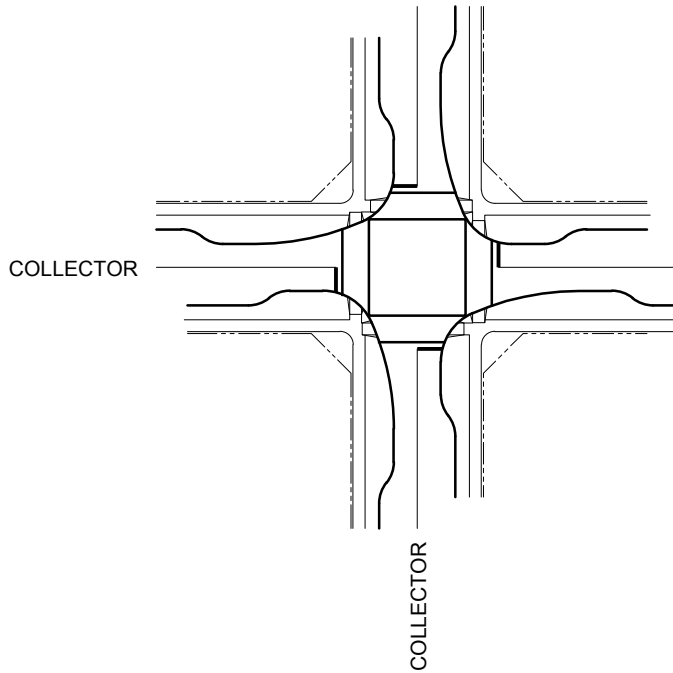

NOTE:

- 1. ALL DIMENSIONS TO FACE OF CURB UNLESS OTHERWISE NOTED. DIMENSIONS ASSUME NO INTERSECTION SKEW OR OFFSET.

**ALL DIMENSIONS
IN METRES UNLESS
OTHERWISE NOTED**

COLLECTOR - COLLECTOR BULB



STANDARD DRAWING

DATE APPROVED: **2025**

DRAWN BY: **FR**

APPROVED: *[Signature]*

DRAWING NUMBER: **3890**

SCALE: **N.T.S.**

CHECKED BY: **JN**

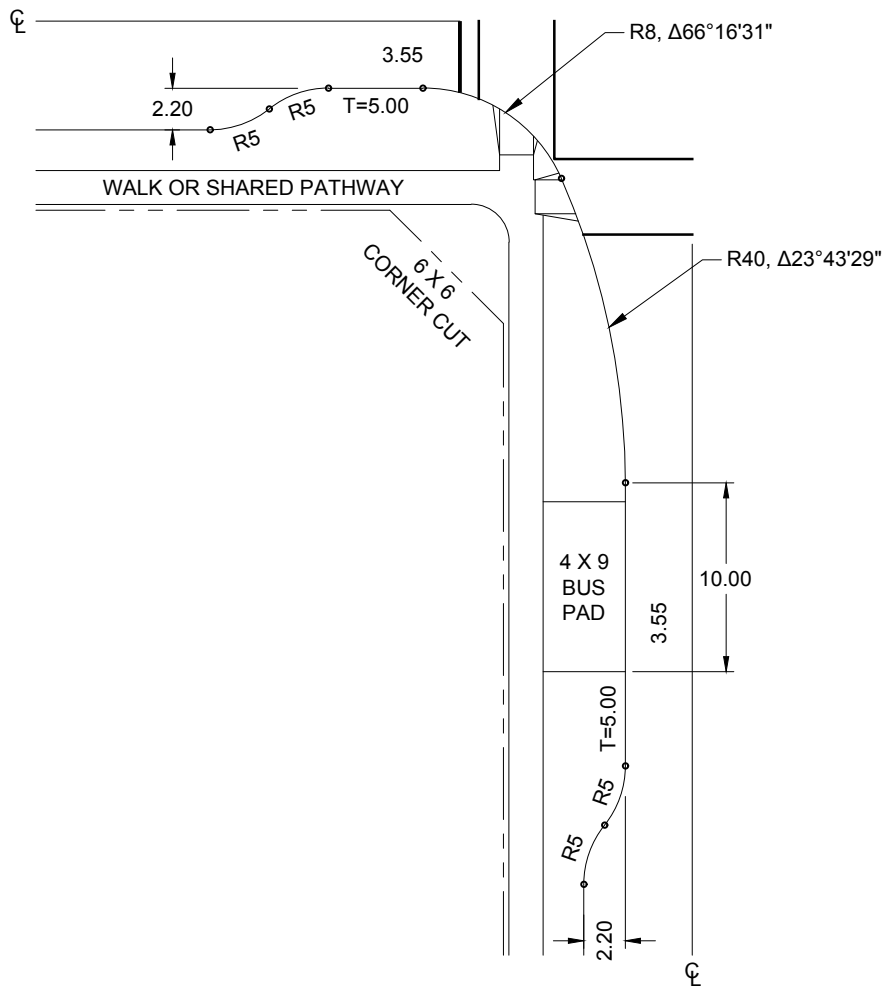

NOTE:

1. ALL DIMENSIONS TO FACE OF CURB UNLESS OTHERWISE NOTED. DIMENSIONS ASSUME NO INTERSECTION SKEW OR OFFSET.

**ALL DIMENSIONS
IN METRES UNLESS
OTHERWISE NOTED**



STANDARD DRAWING

COLLECTOR - COLLECTOR BULB WITH BUS STOP

DATE APPROVED: **2025**
SCALE: **N.T.S.**

DRAWN BY: **FR**
CHECKED BY: **JN**

APPROVED: 

DRAWING NUMBER: **3891**

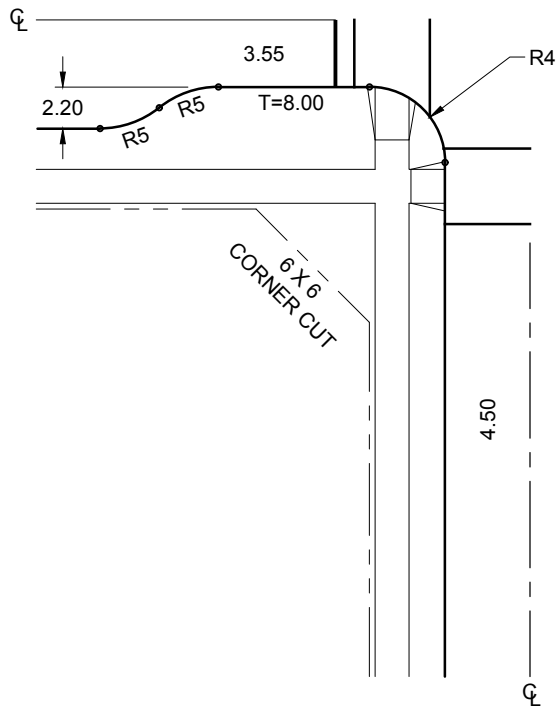

INSET - 4 LEG LAYOUT

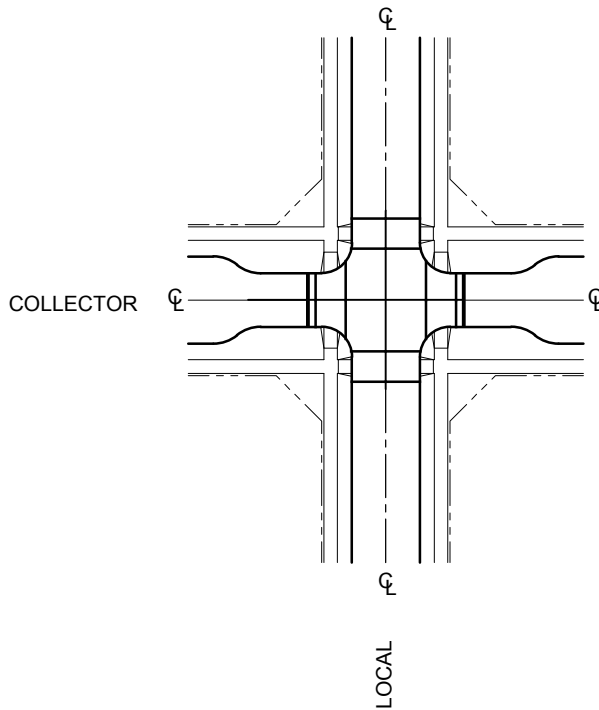

NOTE:

- 1. ALL DIMENSIONS TO FACE OF CURB UNLESS OTHERWISE NOTED. DIMENSIONS ASSUME NO INTERSECTION SKEW OR OFFSET.

**ALL DIMENSIONS
IN METRES UNLESS
OTHERWISE NOTED**

Edmonton
STANDARD DRAWING

COLLECTOR - LOCAL BULB

DATE APPROVED: **2025**
SCALE: **N.T.S.**

DRAWN BY: **FR**
CHECKED BY: **JN**

APPROVED: *[Signature]*

DRAWING NUMBER: **3892**

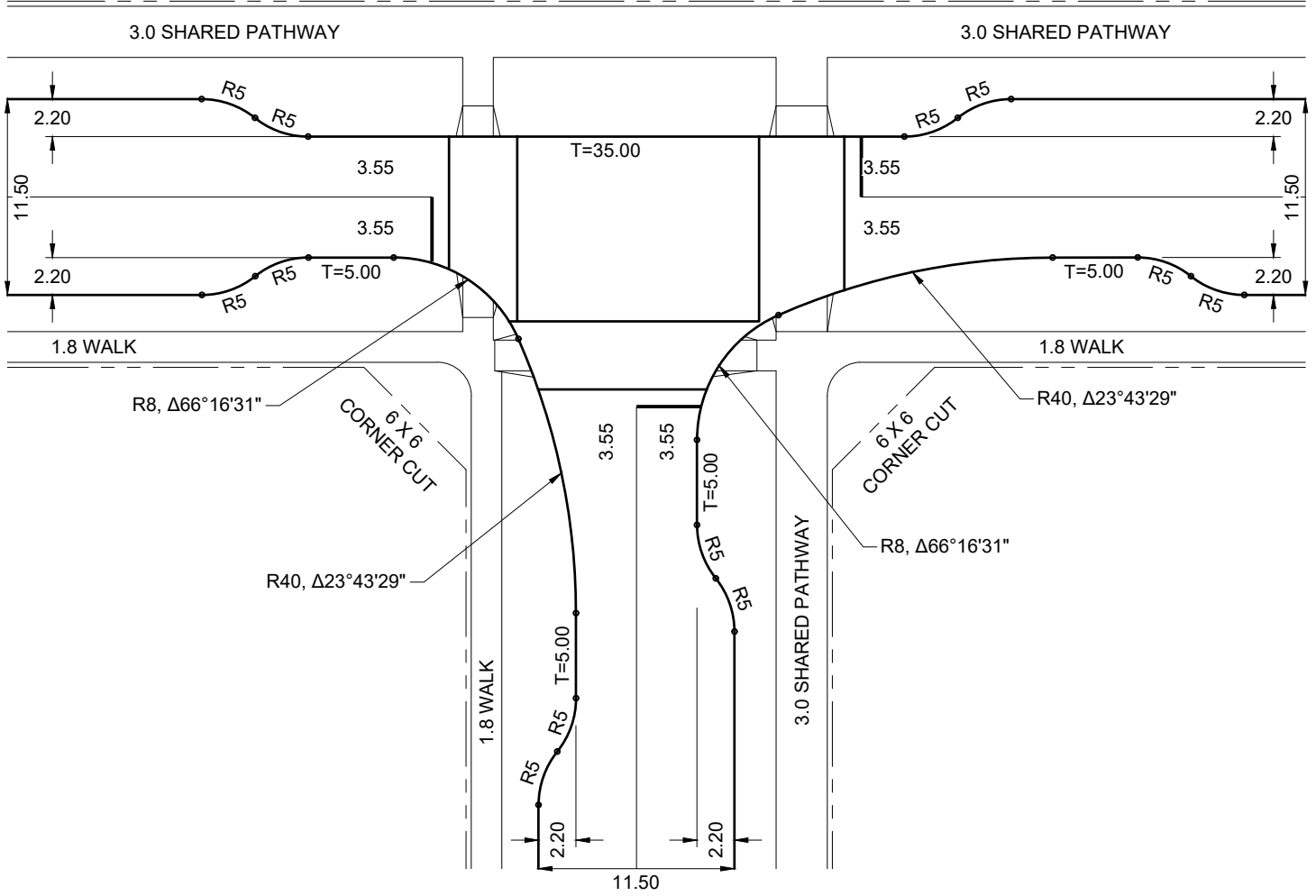

NOTE:

- 1. ALL DIMENSIONS TO FACE OF CURB UNLESS OTHERWISE NOTED. DIMENSIONS ASSUME NO INTERSECTION SKEW OR OFFSET.

**ALL DIMENSIONS
IN METRES UNLESS
OTHERWISE NOTED**



STANDARD DRAWING

COLLECTOR - COLLECTOR T-INTERSECTION BULB

DATE APPROVED: **2025**
SCALE: **N.T.S.**

DRAWN BY: **FR**
CHECKED BY: **JN**

APPROVED: 

DRAWING NUMBER: **3893**

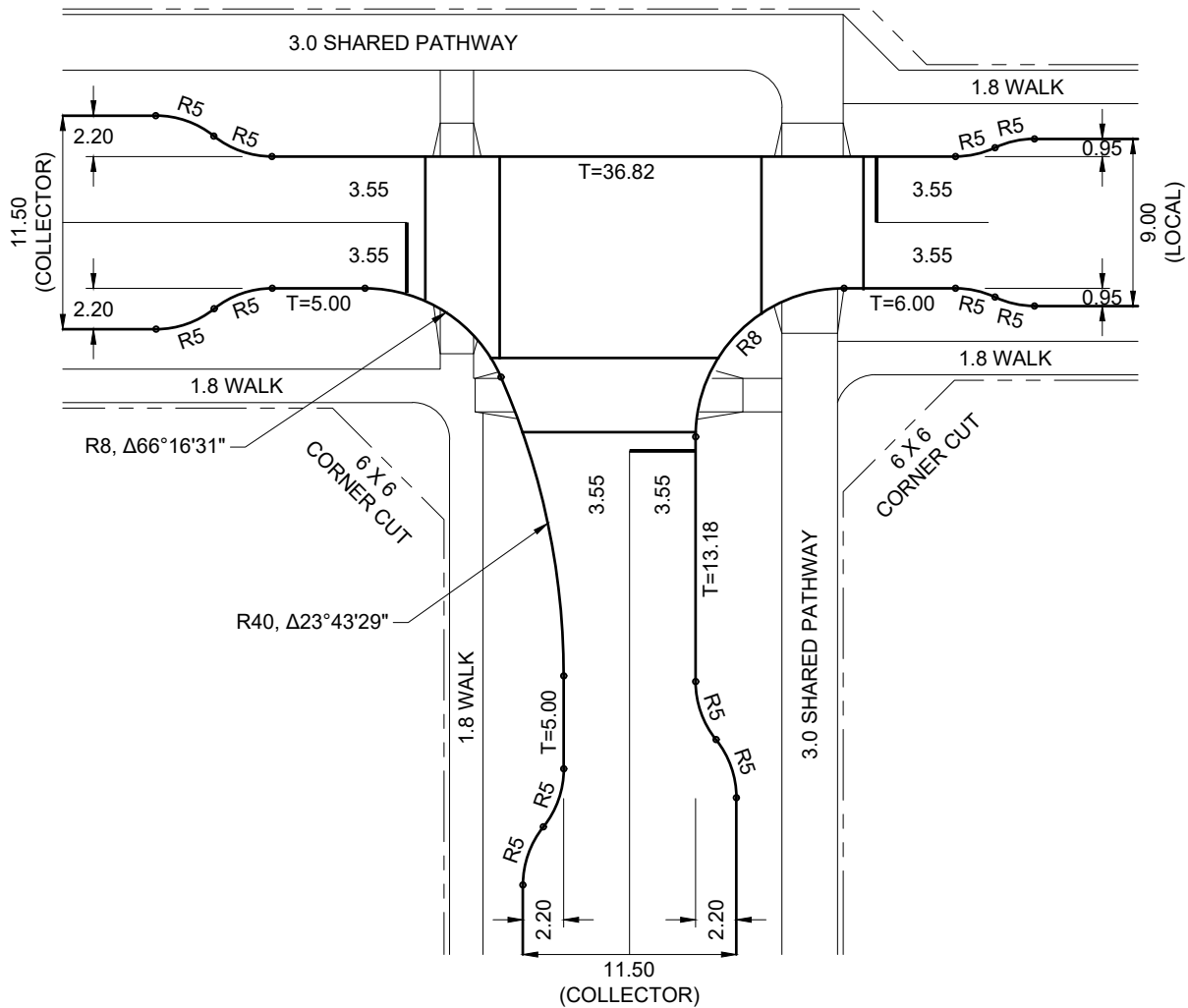

NOTE:

1. ALL DIMENSIONS TO FACE OF CURB UNLESS OTHERWISE NOTED. DIMENSIONS ASSUME NO INTERSECTION SKEW OR OFFSET.

**ALL DIMENSIONS
IN METRES UNLESS
OTHERWISE NOTED**



STANDARD DRAWING

DATE APPROVED: 2025	DRAWN BY: FR	APPROVED: 	DRAWING NUMBER: 3894
SCALE: N.T.S.	CHECKED BY: JN		

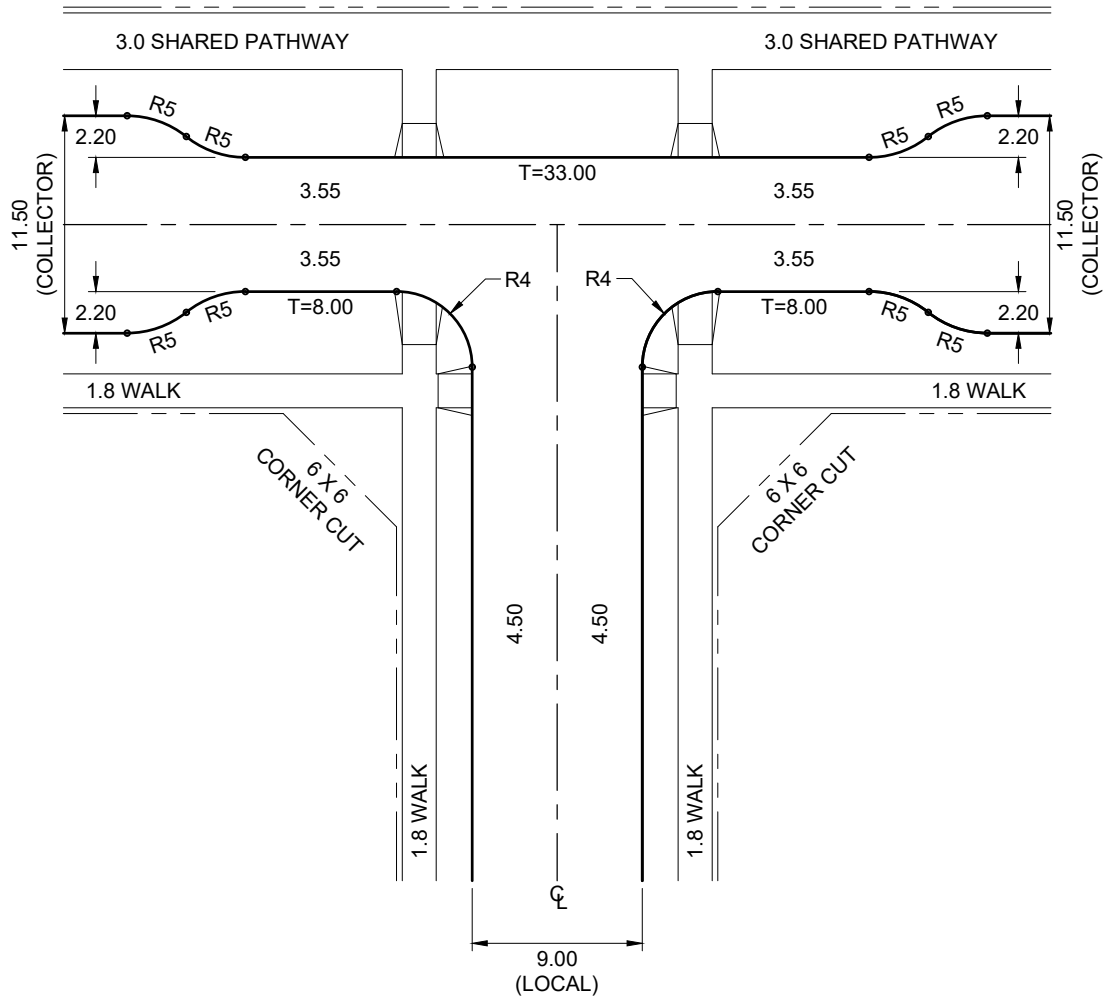

NOTE:

- 1. ALL DIMENSIONS TO FACE OF CURB UNLESS OTHERWISE NOTED. DIMENSIONS ASSUME NO INTERSECTION SKEW OR OFFSET.

**ALL DIMENSIONS
IN METRES UNLESS
OTHERWISE NOTED**



STANDARD DRAWING

LOCAL - COLLECTOR T-INTERSECTION BULB

DATE APPROVED: **2025**
SCALE: **N.T.S.**

DRAWN BY: **FR**
CHECKED BY: **JN**

APPROVED: *[Signature]*

DRAWING NUMBER: **3895**

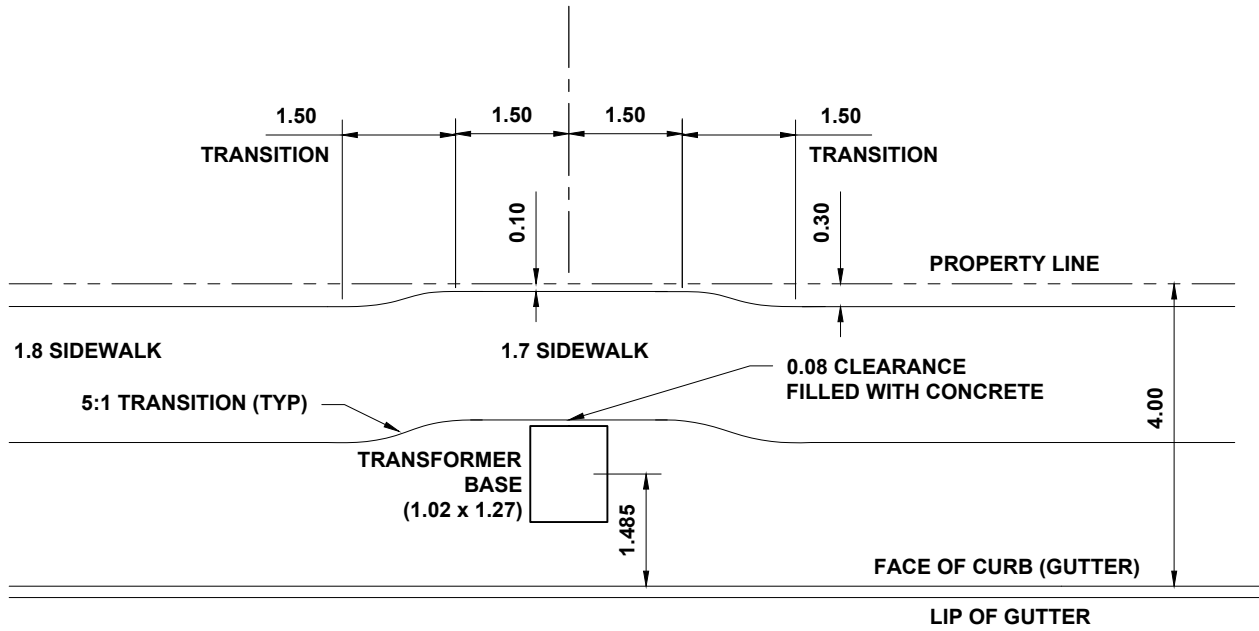

ROLL FACE CURB AND GUTTER

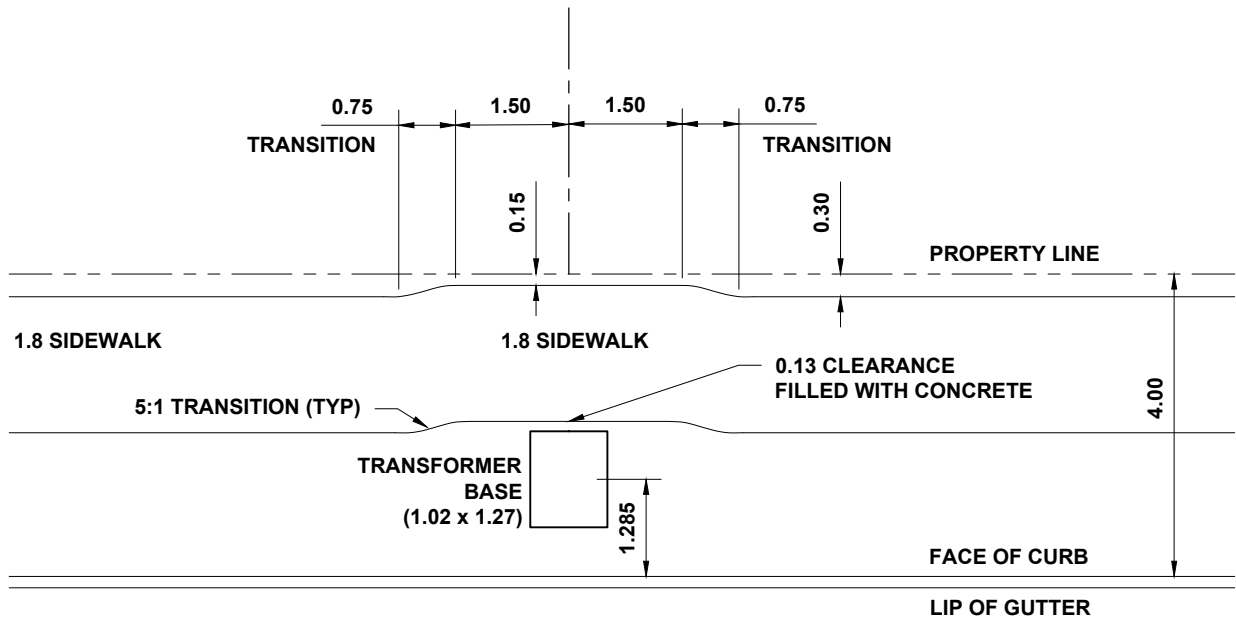

STRAIGHT FACE CURB AND GUTTER

NOTE:

- 1. ONLY FOR SEPARATED WALK WITH 4.0m BOULEVARD
- 2. GROUNDING RODS ARE 0.5m FROM THE TRANSFORMER

**ALL DIMENSIONS
IN METRES UNLESS
OTHERWISE NOTED**



STANDARD DRAWING

BOULEVARD SIDEWALK TRANSITION AT TRANSFORMER

DATE APPROVED: **2025**

DRAWN BY: **FR**

APPROVED: 

DRAWING NUMBER: **3900**

SCALE: **N.T.S.**

CHECKED BY: **JN**



Standard Drawings

SECTION 4000 – TRANSIT DETAILS

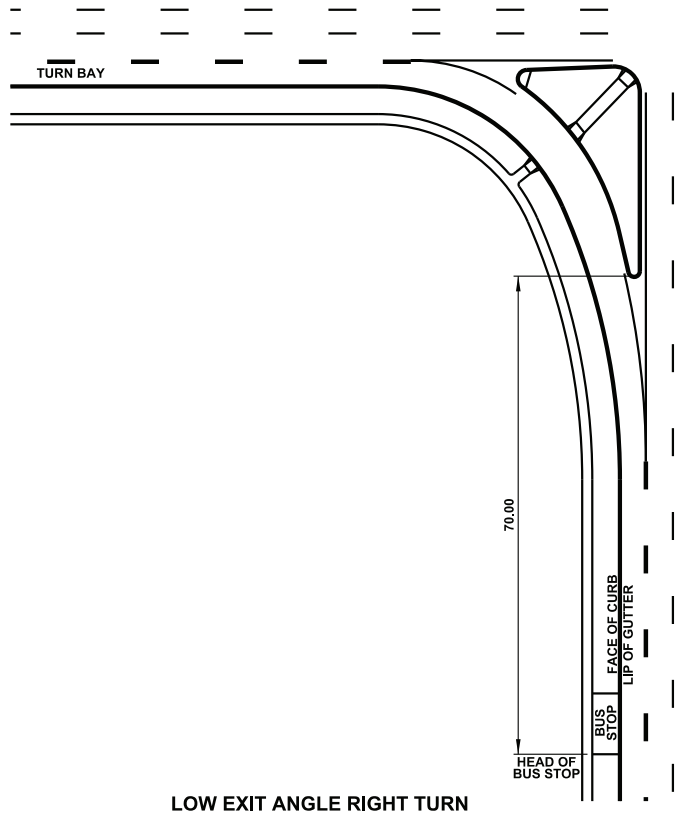
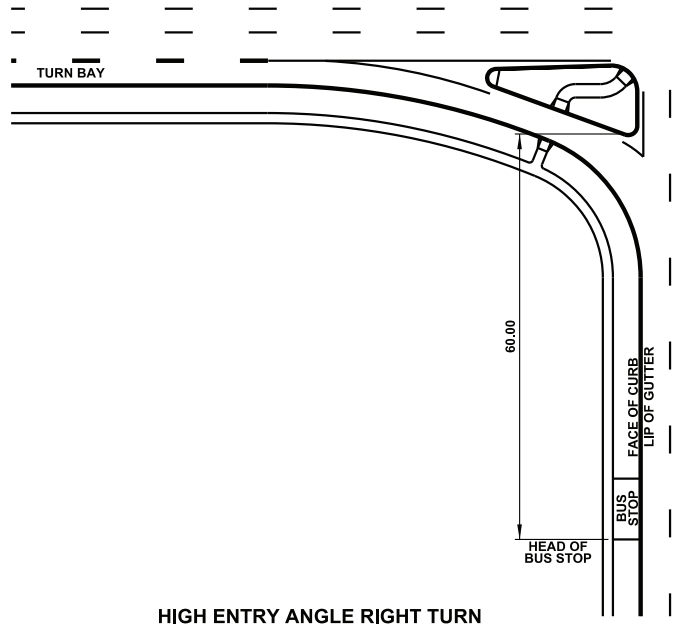

NOTE:

- 1. LOCATION OF BUS STOP AT ROUNDABOUT SEE STANDARD DRAWING #3720.

**ALL DIMENSIONS
IN METRES UNLESS
OTHERWISE NOTED**

**LOCATION OF BUS STOP
(CHANNELIZED INTERSECTION)**



STANDARD DRAWING

DATE APPROVED: **2018**

DRAWN BY: **KSYC**

APPROVED: *M.A.R.*

DRAWING NUMBER: **4010**

SCALE: **N.T.S.**

CHECKED BY: **JN**

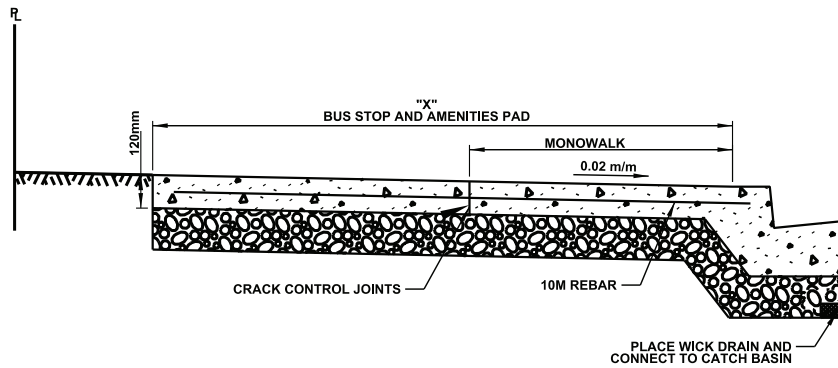
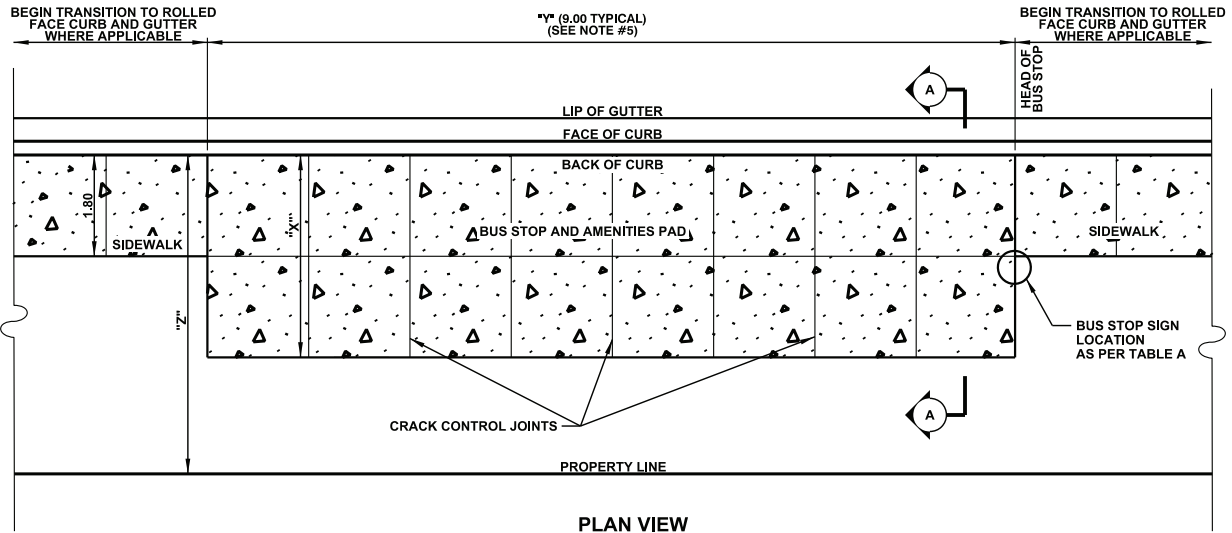

SECTION A-A

TABLE A
BUS STOP AND AMENITIES PAD SIZE

CONDITION	"Z" DISTANCE TO PROPERTY LINE	"X" REQUIRED PAD WIDTH	(SEE NOTE #5) "Y" REQUIRED PAD LENGTH	BUS STOP SIGN LOCATION BEHIND SIDEWALK
OVER CONSTRAINED	"Z" < 2.80	2.10	9.00	HEAD OF PAD
CONSTRAINED	2.80 ≤ "Z" < 3.90	"Z" - 0.30 [3.00 (MAX.)]	12.00	3.00 BACK FROM HEAD OF PAD
NOT CONSTRAINED	"Z" > 3.90	"Z" - 0.30 [4.10 (MAX.)]	9.00	HEAD OF PAD

NOTES:

1. PROVIDE BUS STOP AND AMENITIES PAD WITH WIDTH "X" AND LENGTH "Y" IN ACCORDANCE WITH THE DRAWING NOTES AND TABLE A (SEE ABOVE). PROVIDE APPROPRIATE CRACK CONTROL JOINTS THROUGHOUT.
2. MAINTAIN 0.30m (MIN.) CLEARANCE BETWEEN PROPERTY LINE AND AMENITIES PAD.
3. STRAIGHT FACE CURB AND GUTTER REQUIRED AT BUS STOP.
4. BUS STOP AND AMENITIES PAD TO BE POURED MONOLITHICALLY WITH CURB AND GUTTER.
5. FOR REQUIRED LENGTH:
- ADD 3.00 FOR MULTIPLE, FREQUENT ROUTES
- ADD 5.00 FOR ARTICULATED BUS STOP

**ALL DIMENSIONS
IN METRES UNLESS
OTHERWISE NOTED**

**BUS STOP AND AMENITIES PAD
MONOWALK**



STANDARD DRAWING

DATE APPROVED: **2018**

DRAWN BY: **KSYC**

APPROVED: *M.R.*

DRAWING NUMBER: **4100**

SCALE: **N.T.S.**

CHECKED BY: **JN**

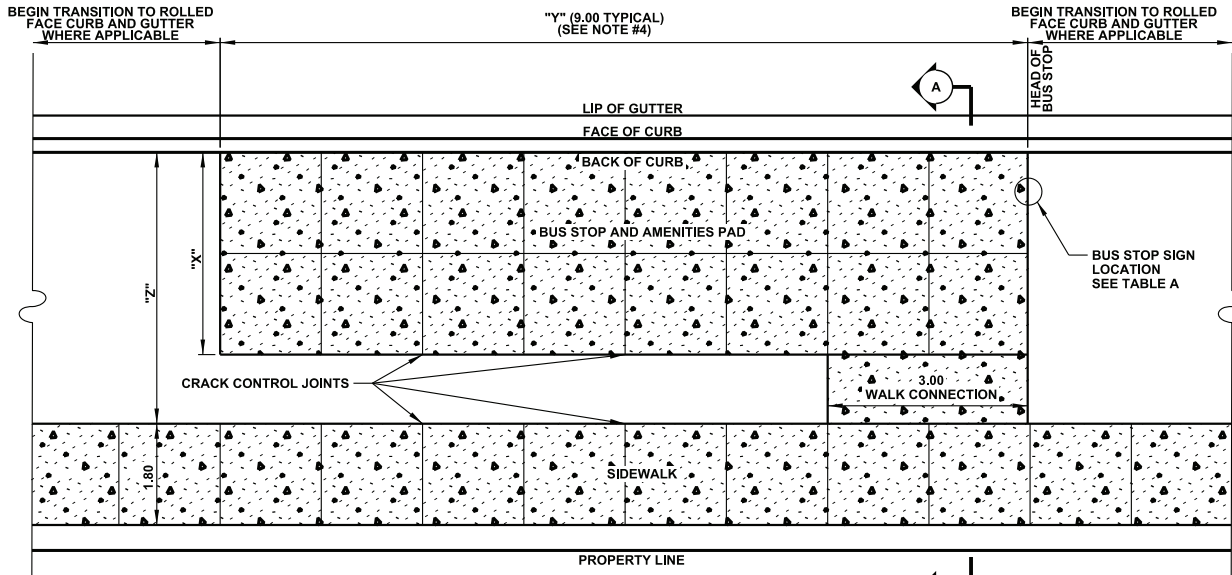

PLAN VIEW

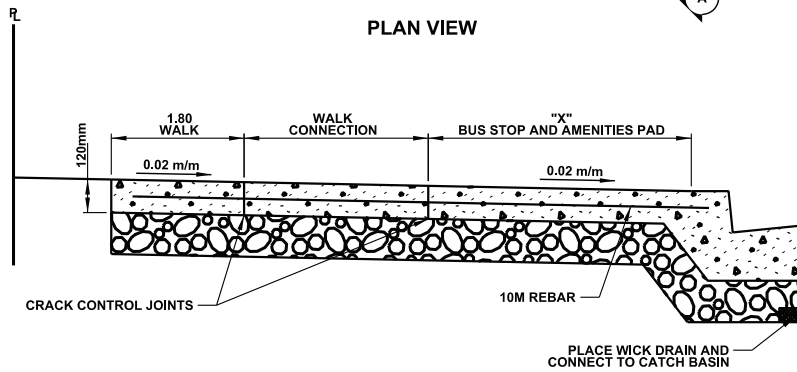

SECTION A-A

TABLE A
BUS STOP AND AMENITIES PAD SIZE

CONDITION	"Z" DISTANCE TO SIDEWALK	"X" REQUIRED PAD WIDTH	"Y" (SEE NOTE #4) REQUIRED PAD LENGTH	BUS STOP SIGN LOCATION
OVER CONSTRAINED	"Z" < 2.25	NOT PERMISSIBLE	NOT PERMISSIBLE	NOT PERMISSIBLE
CONSTRAINED	2.25 ≤ "Z" < 3.60	"X" = "Z"	12.00	3.00 BACK FROM HEAD OF PAD
NOT CONSTRAINED	3.60 ≤ "Z"	"X" = "Z" 4.10 (MAX.)	9.00	HEAD OF PAD

NOTES:

1. PROVIDE BUS STOP AND AMENITIES PAD WITH WIDTH "X" AND LENGTH "Y" IN ACCORDANCE WITH THE DRAWING NOTES AND TABLE A (SEE ABOVE). PROVIDE APPROPRIATE CRACK CONTROL JOINTS THROUGHOUT.
2. IF REQUIRED PAD WIDTH "X" IS LESS THAN 1.00m FROM SIDEWALK, POUR THE CONCRETE PAD TO SIDEWALK. OTHERWISE, PROVIDE 3.00m WIDE WALK CONNECTION AT HEAD OF THE PAD.
3. STRAIGHT FACE CURB AND GUTTER REQUIRED AT BUS STOP.
4. FOR REQUIRED LENGTH:
 - ADD 3.00 FOR MULTIPLE, FREQUENT ROUTES
 - ADD 5.00 FOR ARTICULATED BUS STOP

**ALL DIMENSIONS
IN METRES UNLESS
OTHERWISE NOTED**

**BUS STOP AND AMENITIES PAD
BOULEVARD WALK**



STANDARD DRAWING

DATE APPROVED: **2018**

DRAWN BY: **KSYC**

APPROVED: *M.A.R.*

DRAWING NUMBER: **4110**

SCALE: **N.T.S.**

CHECKED BY: **JN**

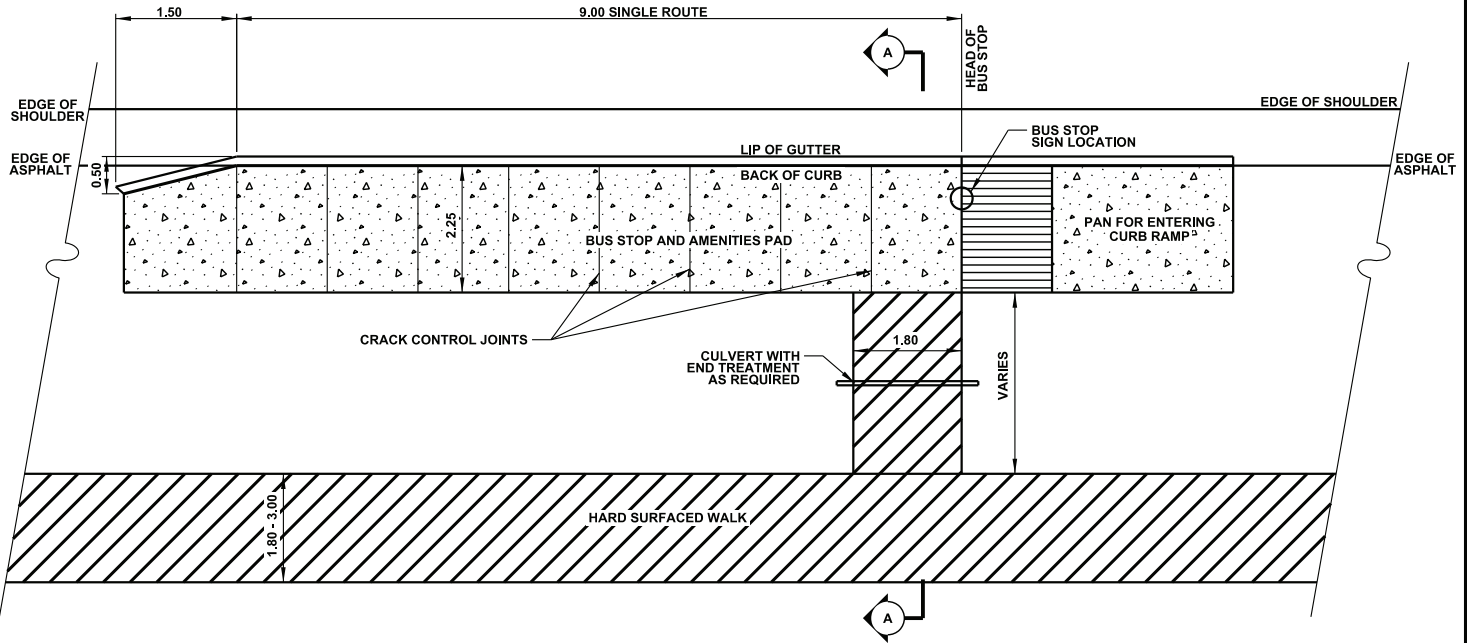

PLAN VIEW

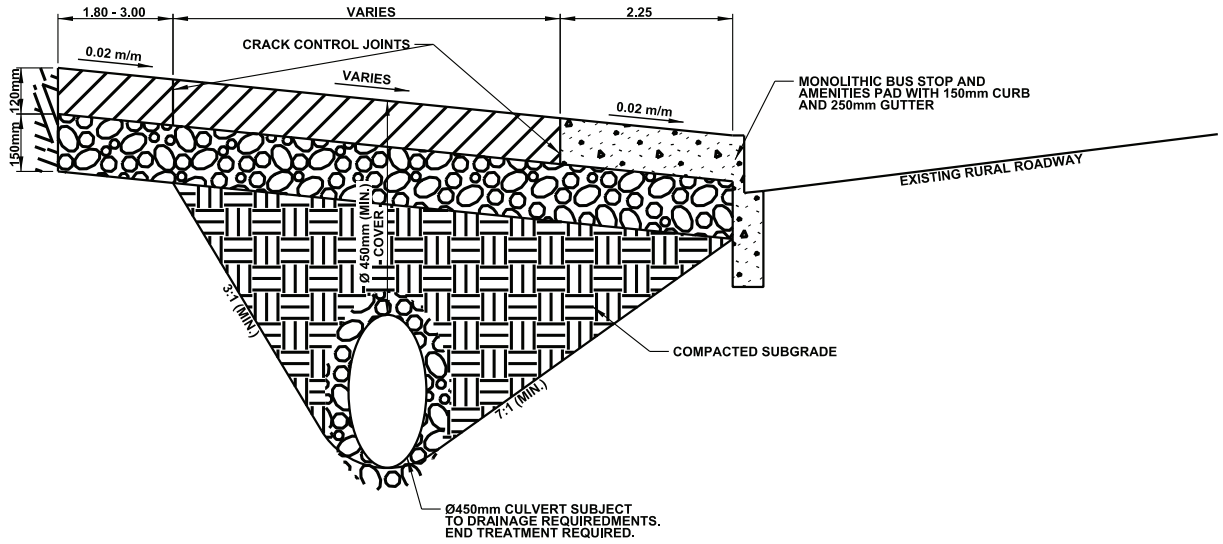

SECTION A-A

NOTES:

1. STRAIGHT FACE CURB AND GUTTER REQUIRED AT BUS STOP.
2. CULVERT DIAMETER SEE DRAWING #3020.
3. CURB RAMP AT HEAD OF BUS STOP IS REQUIRED IF THERE ARE NO EXISTING BOULEVARD CONNECTION. CURB RAMP TO BE FLUSHED WITH EDGE OF ASPHALT.
4. RAILING REQUIREMENT AT BACK OF BUS STOP TO BE DETERMINED AT DETAILED DESIGN TO SATISFACTION OF CITY OF EDMONTON.

**ALL DIMENSIONS
IN METRES UNLESS
OTHERWISE NOTED**

**BUS STOP AND AMENITIES PAD
RURAL ROADWAY**



STANDARD DRAWING

DATE APPROVED: **2018**

SCALE: **N.T.S.**

DRAWN BY: **KSYC**

CHECKED BY: **JN**

APPROVED: *M.A.R.*

DRAWING NUMBER: **4200**

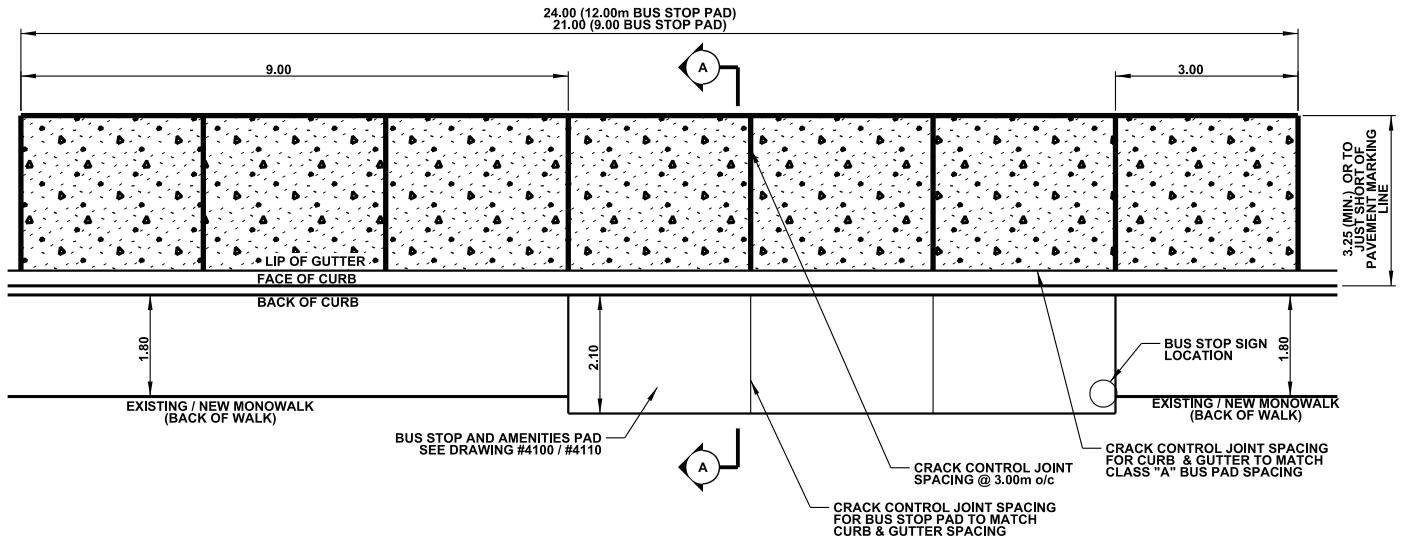

PLAN VIEW

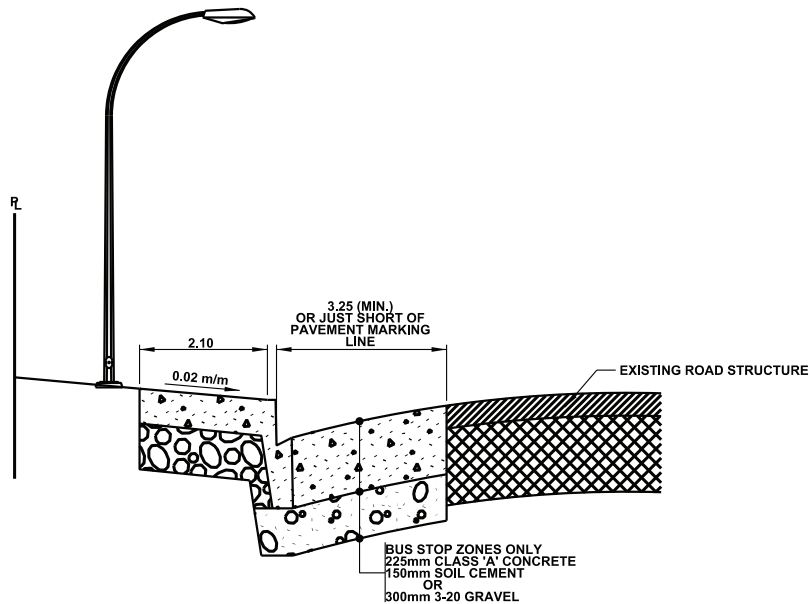

SECTION A-A

NOTES:

1. STRAIGHT FACE CURB AND GUTTER REQUIRED AT BUS STOP.

ALL DIMENSIONS
IN METRES UNLESS
OTHERWISE NOTED



STANDARD DRAWING

CLASS 'A' CONCRETE BUS STOP PAD
(RETROFIT)

DATE APPROVED: 2018

DRAWN BY: KSYC

APPROVED: *M.R.*

DRAWING NUMBER: 4250

SCALE: N.T.S.

CHECKED BY: JN

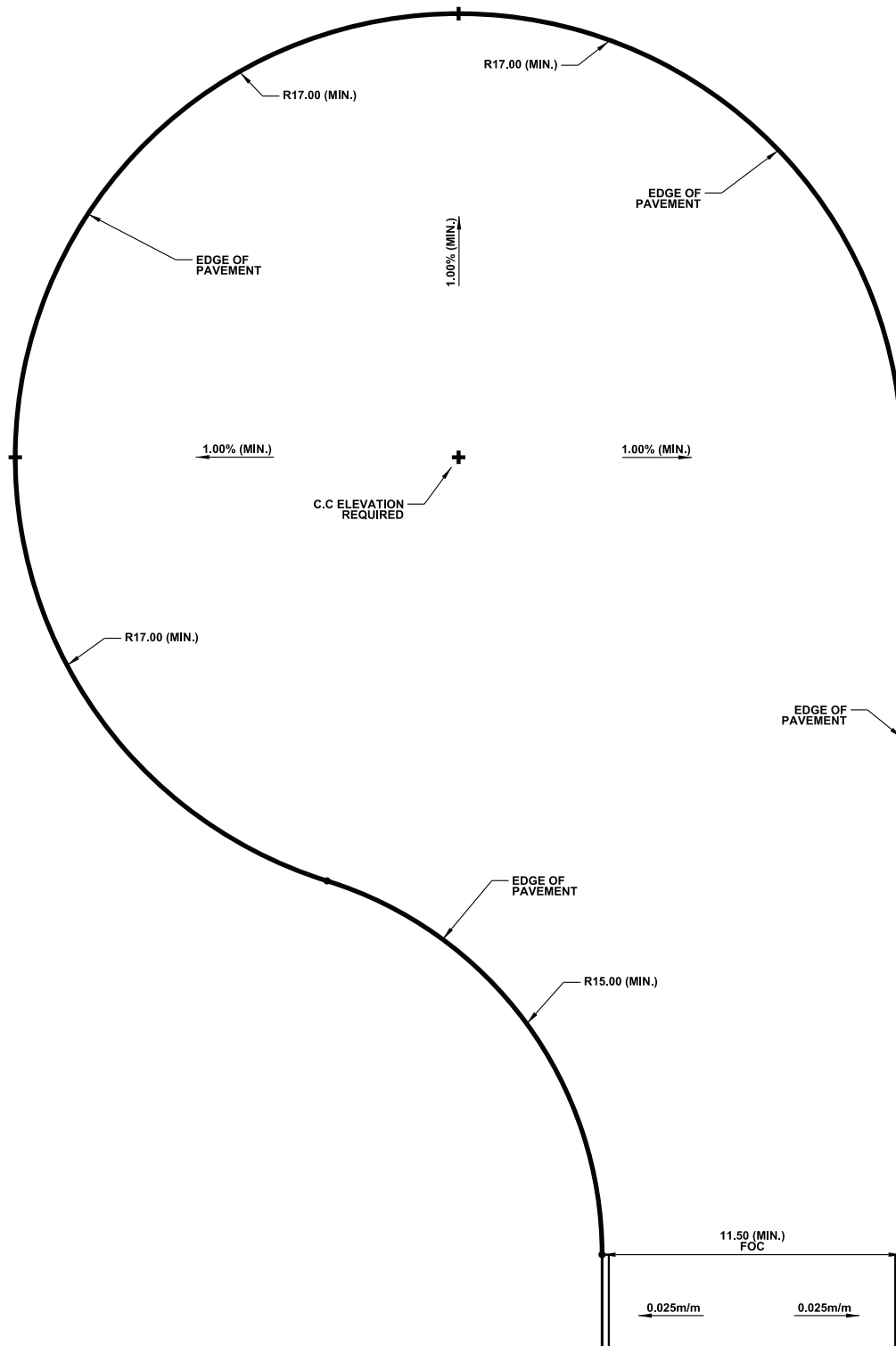

NOTES:

- 1. PROVIDE ELEVATION FOR ALL CROSS SYMBOL (+) SHOWN.
- 2. FOR TEMPORARY TURNAROUND WITH NO CURB AND GUTTER, PLACE MINI BARRIERS OR INSTALL BARRIER POSTS @ 1.50m ON CENTRE ALONG OUTSIDE EDGE OF PAVEMENT ON TURNAROUND.

**ALL DIMENSIONS
IN METRES UNLESS
OTHERWISE NOTED**



STANDARD DRAWING

**TRANSIT TURNAROUND
(OFFSET)**

DATE APPROVED: **2018**
SCALE: **N.T.S.**

DRAWN BY: **KSYC**
CHECKED BY: **JN**

APPROVED: *M.A.R.*

DRAWING NUMBER: **4300**

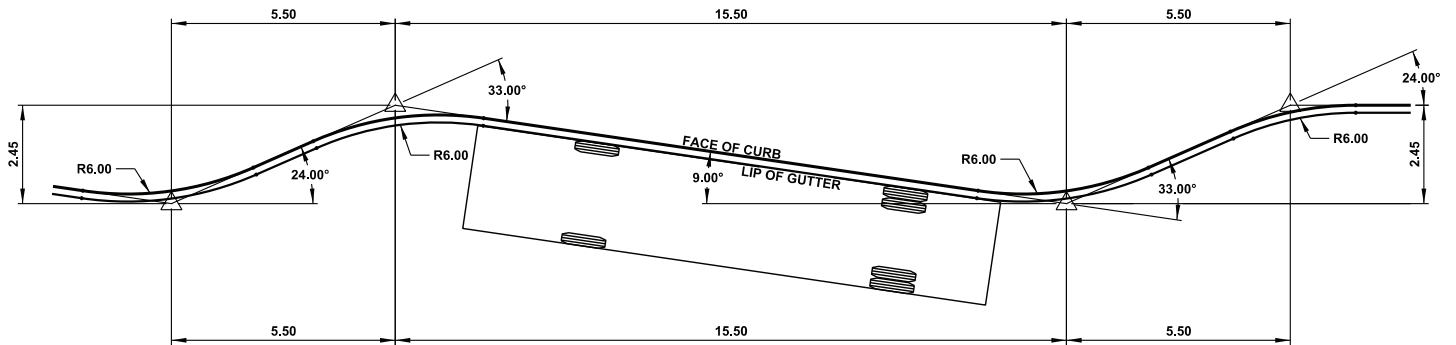

**BUS SAWTOOTH TRANSIT BAY
STANDARD (12.00)**

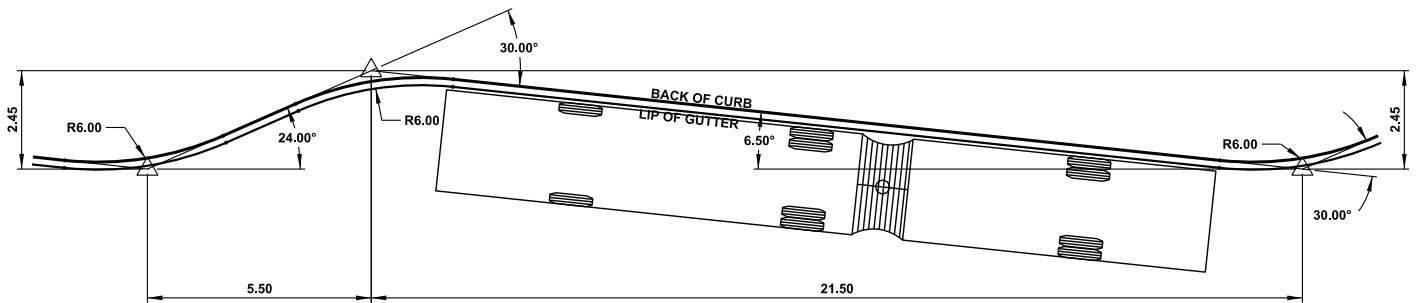

**SAWTOOTH TRANSIT BAY
ARTICULATED (18.00)**

NOTE:

1. CROSSWALKS SHALL BE ACCOMMODATED BY PROVIDING 4.00m LENGTH OF STRAIGHT CURB BETWEEN CONSECUTIVE BAYS.
2. ALL RADII ARE TO LIP OF GUTTER.

**ALL DIMENSIONS
IN METRES UNLESS
OTHERWISE NOTED**



STANDARD DRAWING

**SAWTOOTH TRANSIT BAY
TRANSIT TERMINAL SITE**

DATE APPROVED: **2018**

SCALE: **N.T.S.**

DRAWN BY: **KSYC**

CHECKED BY: **JN**

APPROVED: *M.A.R.*

DRAWING NUMBER: **4400**

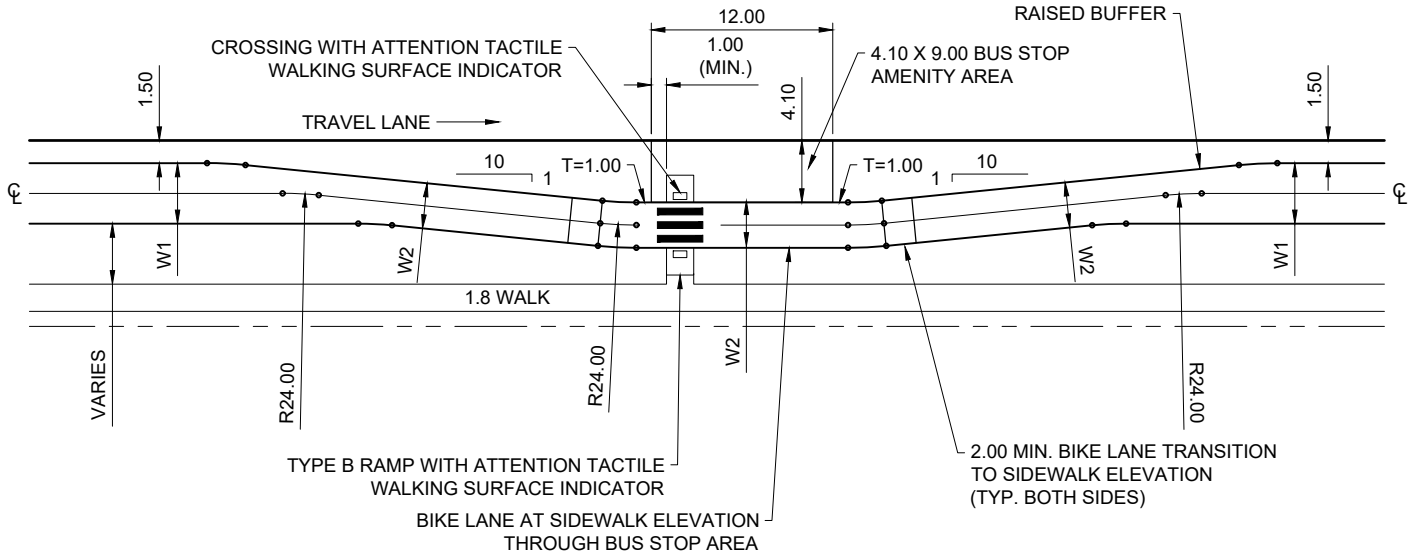

FACILITY TYPE	W1	W2
BI-DIRECTIONAL - DISTRICT CONNECTOR	4.00	3.00
BI-DIRECTIONAL - NEIGHBOURHOOD	3.00	3.00
UNI-DIRECTIONAL - DISTRICT CONNECTOR	2.50	2.10
UNI-DIRECTIONAL - NEIGHBOURHOOD	2.10	1.80

**ALL DIMENSIONS
IN METRES UNLESS
OTHERWISE NOTED**

BIKE LANE TRANSIT STOP ISLAND



STANDARD DRAWING

DATE APPROVED: **2025**

DRAWN BY: **FR**

APPROVED: *[Signature]*

DRAWING NUMBER: **4500**

SCALE: **N.T.S.**

CHECKED BY: **JN**

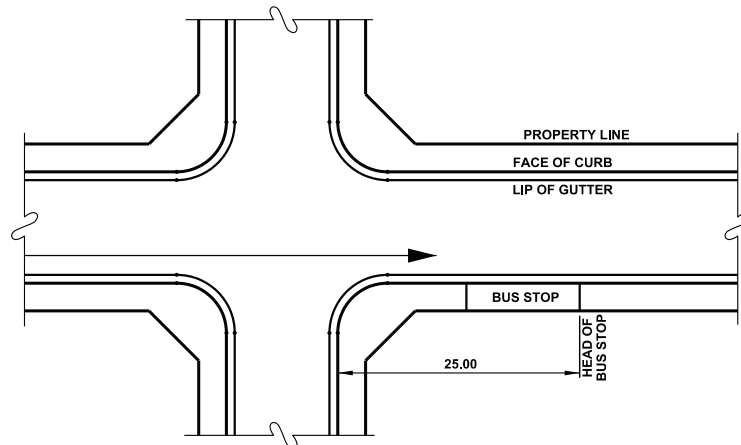

BUS GOES STRAIGHT THROUGH

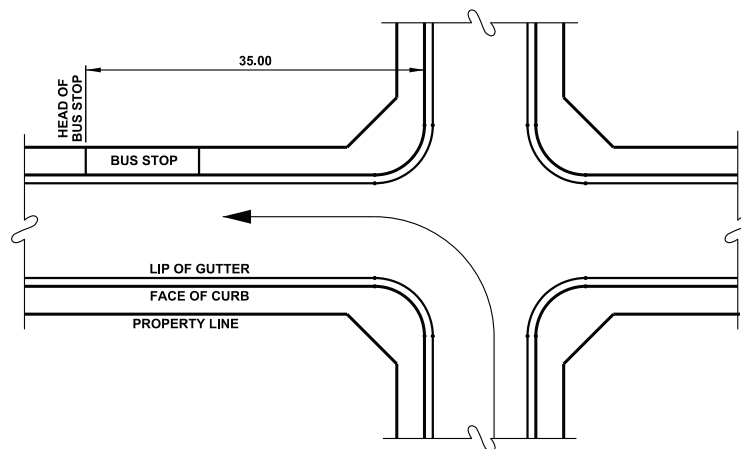

BUS MAKES A LEFT TURN

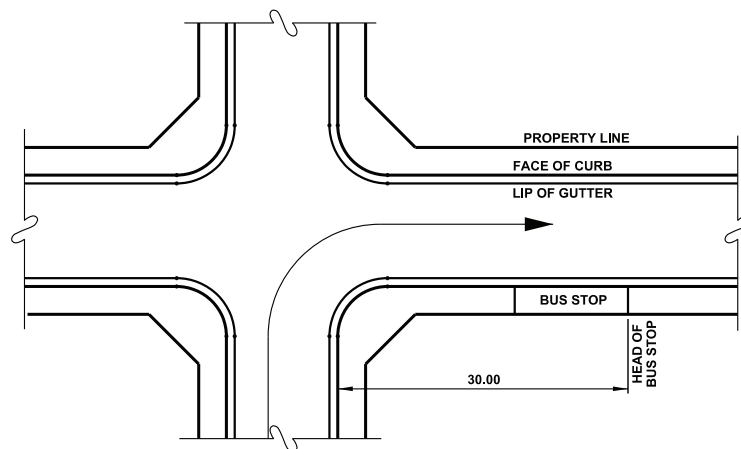

BUS MAKES A RIGHT TURN

NOTES:

- 1. STRAIGHT FACE CURB AND GUTTER REQUIRED AT BUS STOP

**ALL DIMENSIONS
IN METRES UNLESS
OTHERWISE NOTED**

**LOCATION OF BUS STOP
(UNCHANNELIZED INTERSECTION)**



STANDARD DRAWING

DATE APPROVED: **2018**

DRAWN BY: **KSYC**

APPROVED: *M.R.*

DRAWING NUMBER: **4000**

SCALE: **N.T.S.**

CHECKED BY: **JN**



Standard Drawings

SECTION 5000 – CONSTRUCTION DETAILS

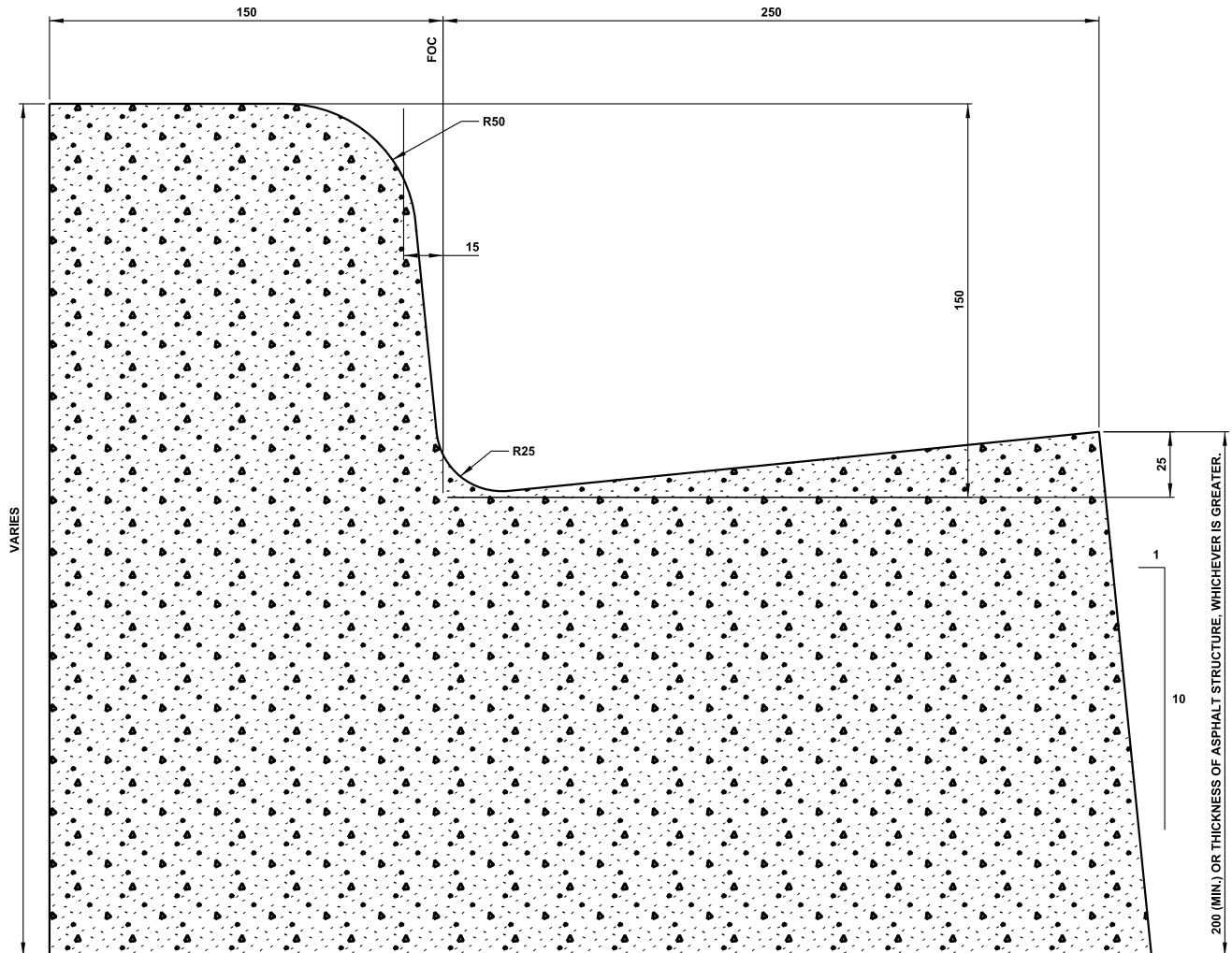

**ALL DIMENSIONS
IN MILLIMETRES UNLESS
OTHERWISE NOTED**



STANDARD DRAWING

150mm CURB WITH 250mm GUTTER

DATE APPROVED: **2018**

DRAWN BY: **KSYC**

APPROVED: *M.A.R.*

DRAWING NUMBER: **5000**

SCALE: **N.T.S.**

CHECKED BY: **JN**

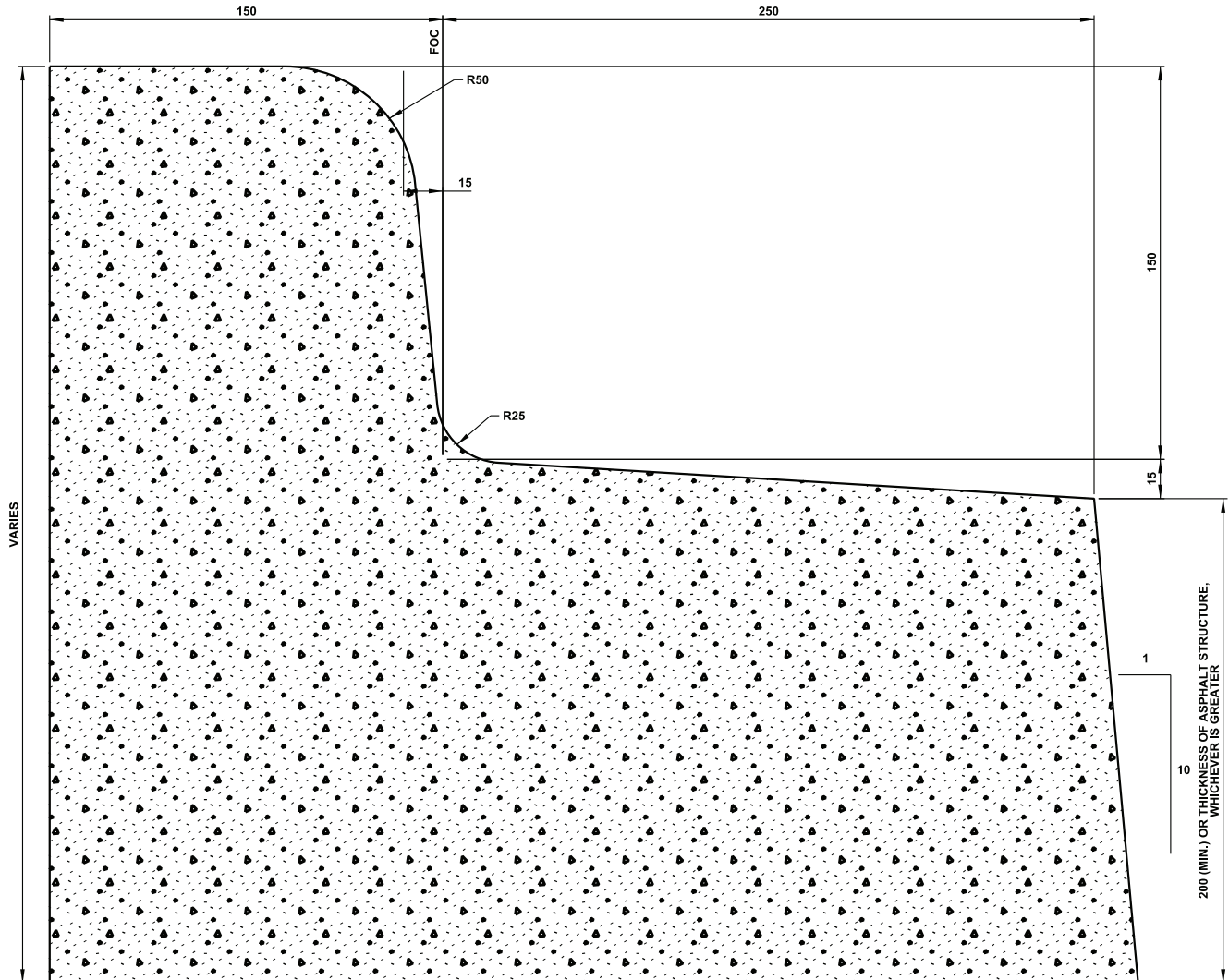

NOTES:

- 1. LOCATION OF REVERSE CURB AND GUTTER ARE SUBJECT TO CITY OF EDMONTON APPROVAL.

**ALL DIMENSIONS
IN MILLIMETRES UNLESS
OTHERWISE NOTED**



150mm CURB WITH REVERSE 250mm GUTTER

DATE APPROVED: **2018**
SCALE: **N.T.S.**

DRAWN BY: **KSYC**
CHECKED BY: **JN**

APPROVED: *M.A.R.*

DRAWING NUMBER: **5001**

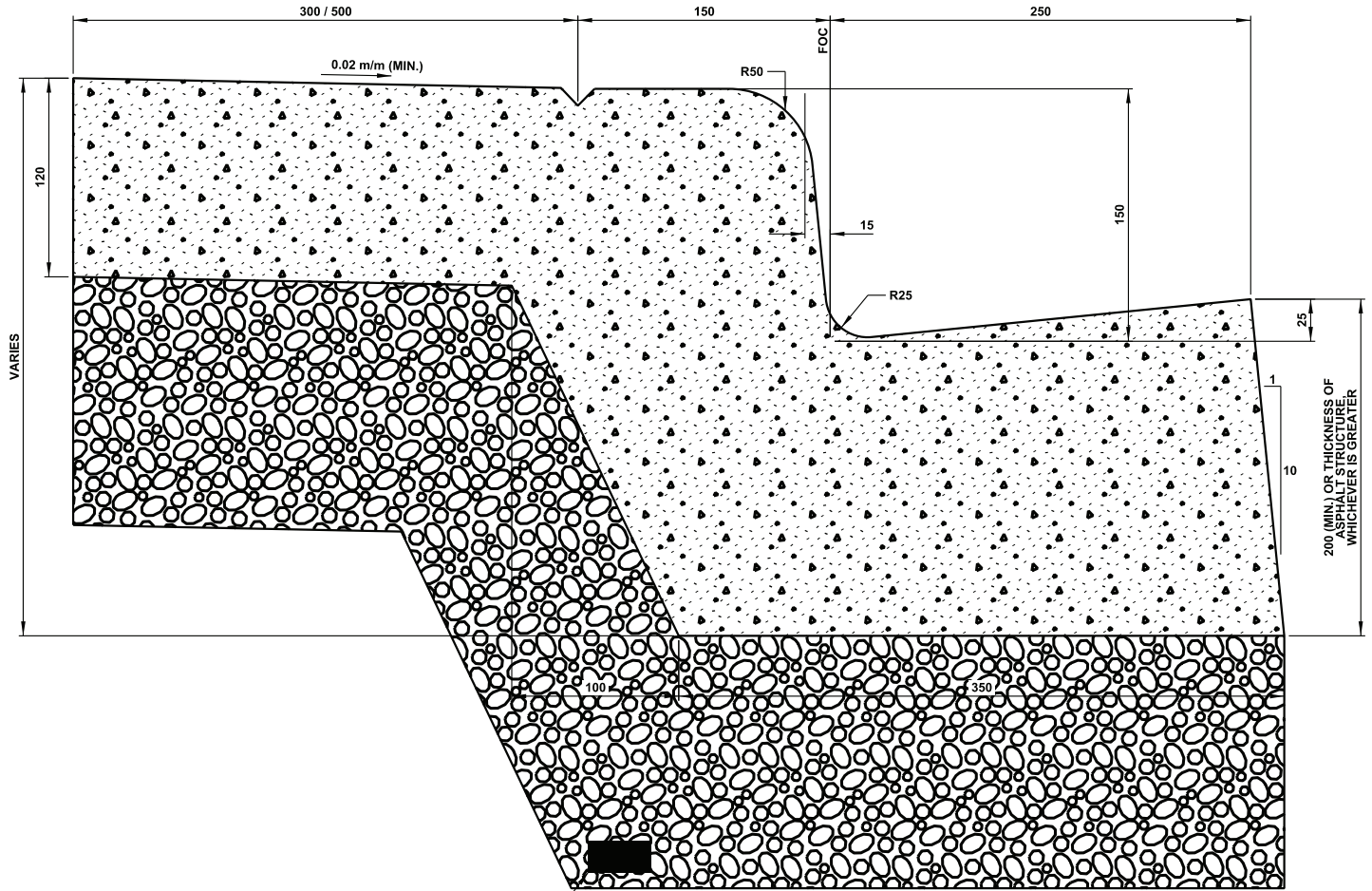

PLACE WICK DRAIN AND CONNECT TO CATCH BASIN WHERE APPLICABLE

NOTES:

1. CONCRETE HEADER TO BE POURED MONOLITHICALLY WITH CURB AND GUTTER.
2. LANDSCAPED MEDIAN HEADER WIDTH TO BE 500mm. ALL OTHER MEDIAN HEADER WIDTH TO BE 300mm.

ALL DIMENSIONS IN MILLIMETRES UNLESS OTHERWISE NOTED



STANDARD DRAWING

150mm CURB AND 250mm GUTTER WITH MONO CONCRETE HEADER

DATE APPROVED: **2018**

DRAWN BY: **KSYC**

APPROVED: *M.R.*

DRAWING NUMBER: **5010**

SCALE: **N.T.S.**

CHECKED BY: **JN**

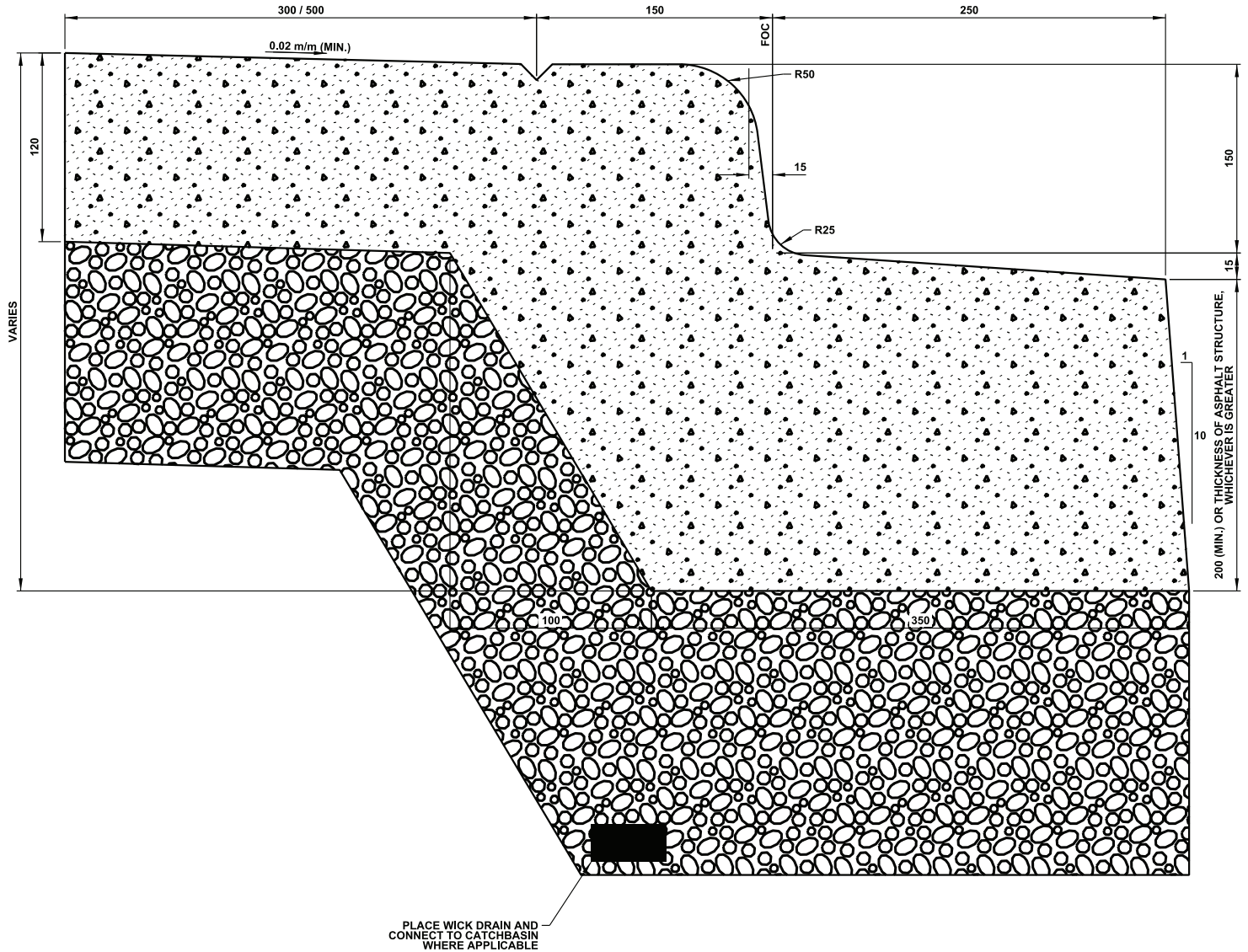

NOTE:

1. CONCRETE HEADER TO BE POURED MONOLITHICALLY WITH CURB AND GUTTER.
2. LANDSCAPED MEDIAN HEADER WIDTH TO BE 500mm. ALL OTHER MEDIAN HEADER WIDTH TO BE 300mm.

ALL DIMENSIONS IN MILLIMETRES UNLESS OTHERWISE NOTED



150mm CURB AND 250mm REVERSE GUTTER WITH MONO CONCRETE HEADER

DATE APPROVED: **2018**

SCALE: **N.T.S.**

DRAWN BY: **KSYC**

CHECKED BY: **JN**

APPROVED: *M.A.R.*

DRAWING NUMBER: **5011**

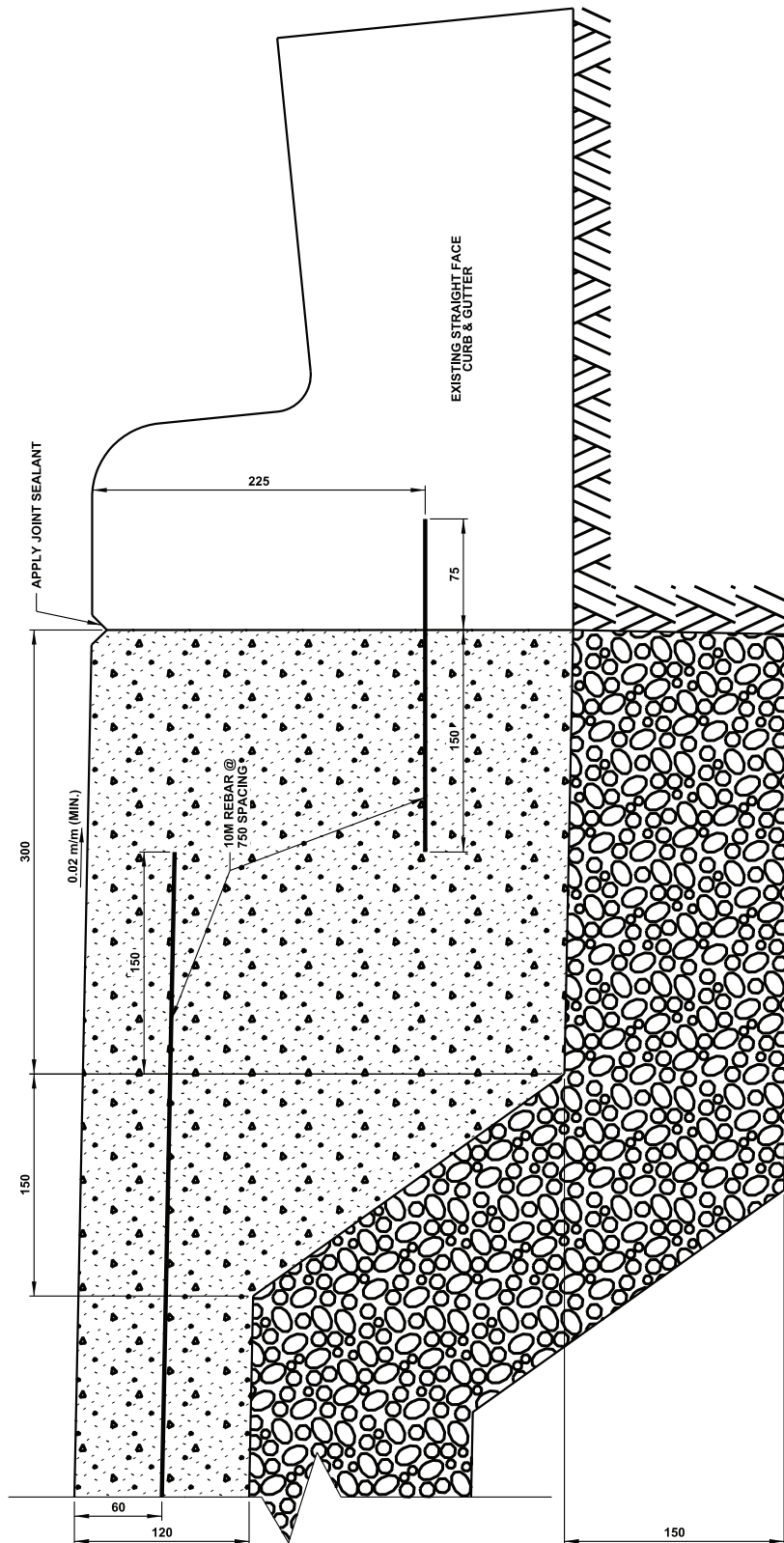

ALL DIMENSIONS
IN MILLIMETRES UNLESS
OTHERWISE NOTED

- NOTES:
1. ALL NEW CONSTRUCTION REQUIRES CURBLINE WALK AND BUS STOP PADS TO BE POURED MONOLITHICALLY WITH CURB AND GUTTER.
 2. THIS METHOD OF RETROFIT CONSTRUCTION CANNOT BE USED UNLESS AUTHORIZED BY THE CITY OF EDMONTON.
 3. EPOXY REBAR INTO EXISTING CURB AND GUTTER.



STANDARD DRAWING

STRAIGHT FACE CONCRETE CURBLINE WALK / BUS STOP (RETROFIT)

DATE APPROVED: 2018

DRAWN BY: KSYC

APPROVED: *M.A.R.*

DRAWING NUMBER: 5020

SCALE: N.T.S.

CHECKED BY: JN

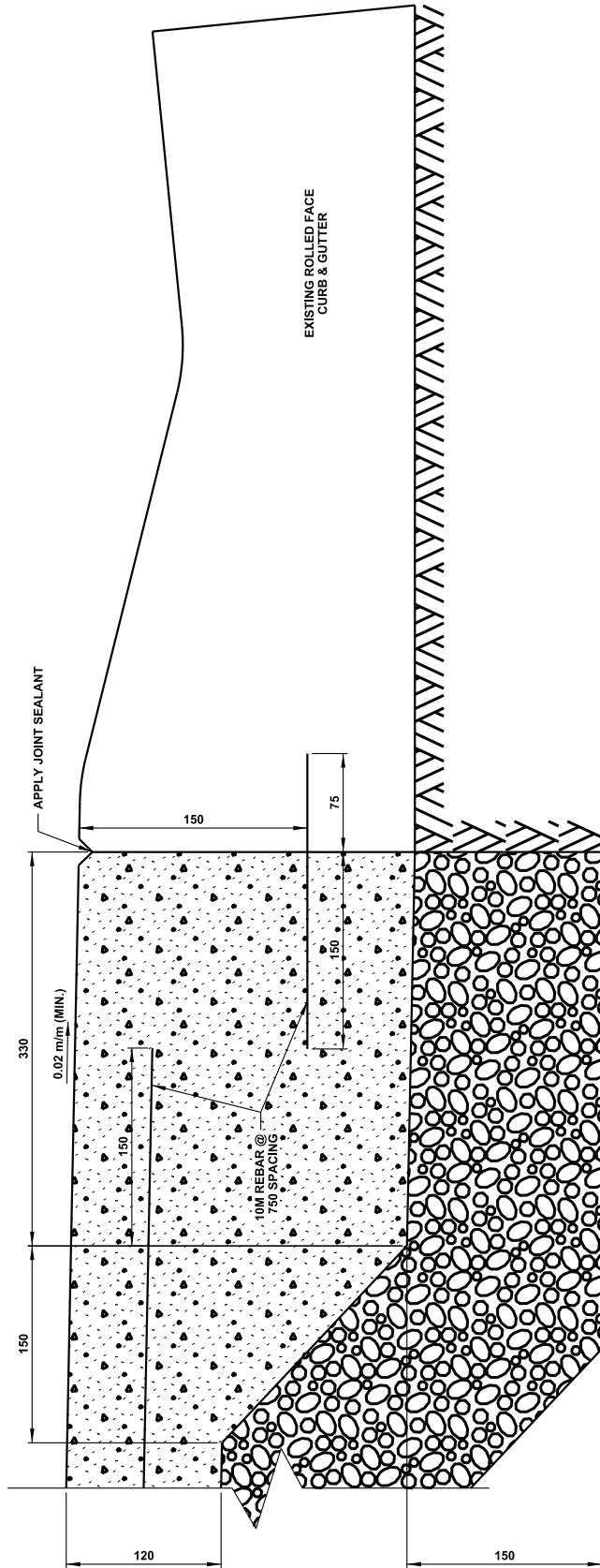

ALL DIMENSIONS
IN MILLIMETRES UNLESS
OTHERWISE NOTED

NOTES:

1. ALL NEW CONSTRUCTION REQUIRES CURBLINE WALK AND BUS STOP PADS TO BE POURED MONOLITHICALLY WITH CURB AND GUTTER.
2. THIS METHOD OF RETROFIT CONSTRUCTION CANNOT BE USED UNLESS AUTHORIZED BY THE CITY OF EDMONTON.
3. EPOXY REBAR INTO EXISTING CURB AND GUTTER.



STANDARD DRAWING

ROLLED FACE CURBLINE WALK (RETROFIT)

DATE APPROVED: **2018**

DRAWN BY: **KSYC**

APPROVED: *M.A.R.*

DRAWING NUMBER: **5021**

SCALE: **N.T.S.**

CHECKED BY: **JN**

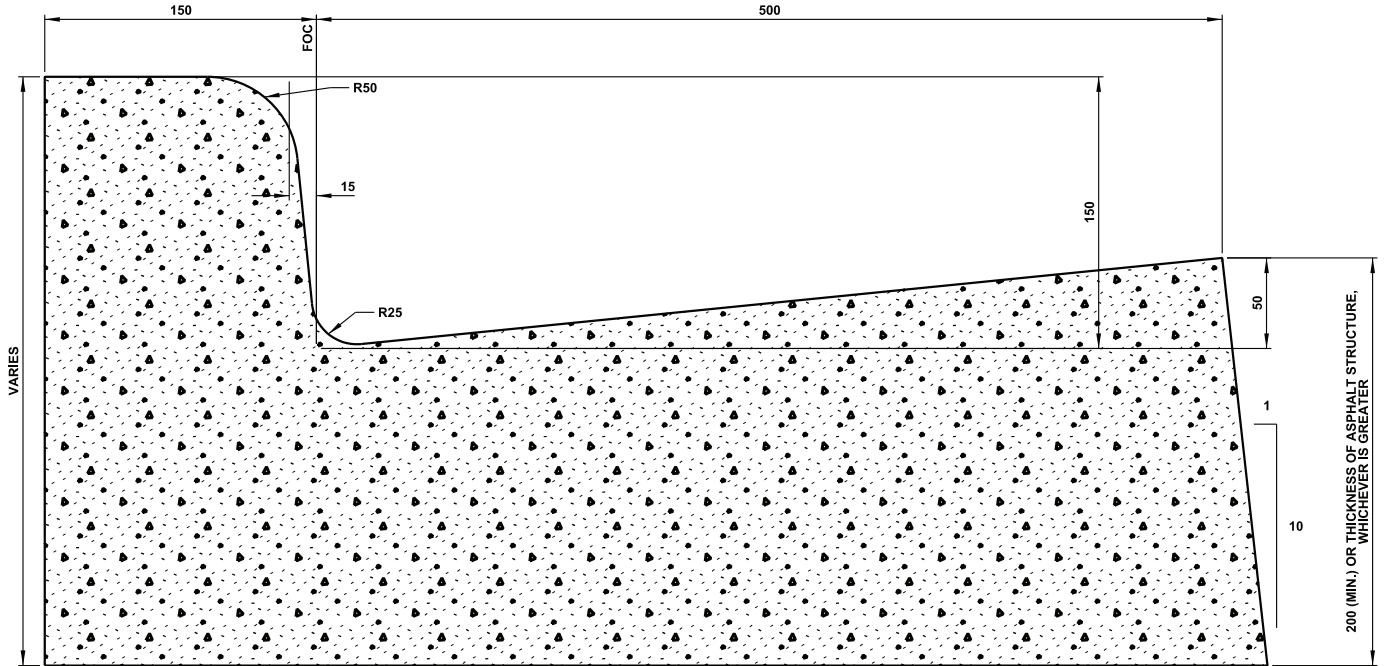

**ALL DIMENSIONS
IN MILLIMETRES UNLESS
OTHERWISE NOTED**



STANDARD DRAWING

150mm CURB AND 500mm GUTTER (RETROFIT)

DATE APPROVED: **2018**

DRAWN BY: **KSYC**

APPROVED: *M.A.R.*

DRAWING NUMBER: **5022**

SCALE: **N.T.S.**

CHECKED BY: **JN**

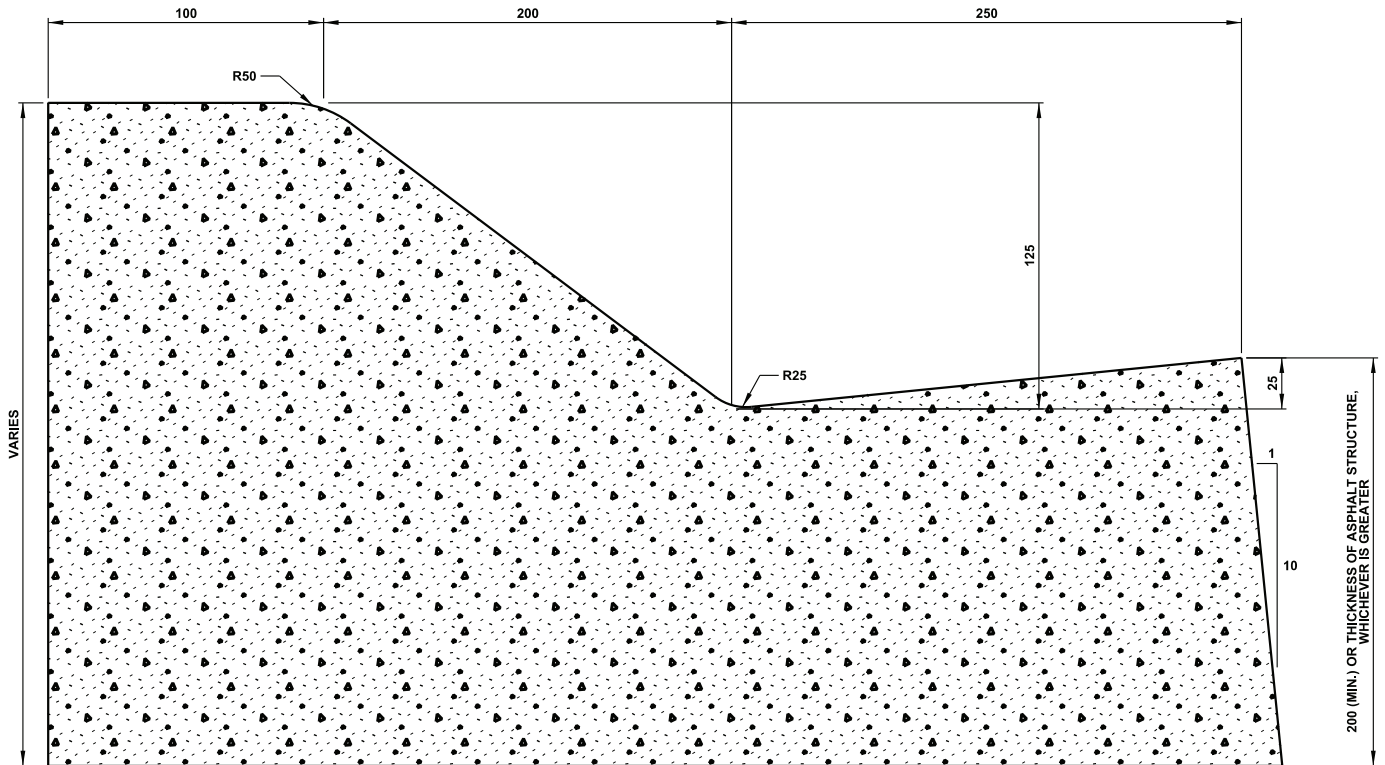

**ALL DIMENSIONS
IN MILLIMETRES UNLESS
OTHERWISE NOTED**



STANDARD DRAWING

125mm SEMI-MOUNTABLE CURB AND 250mm GUTTER

DATE APPROVED: **2018**

DRAWN BY: **KSYC**

APPROVED: *M.A.R.*

DRAWING NUMBER: **5023**

SCALE: **N.T.S.**

CHECKED BY: **JN**

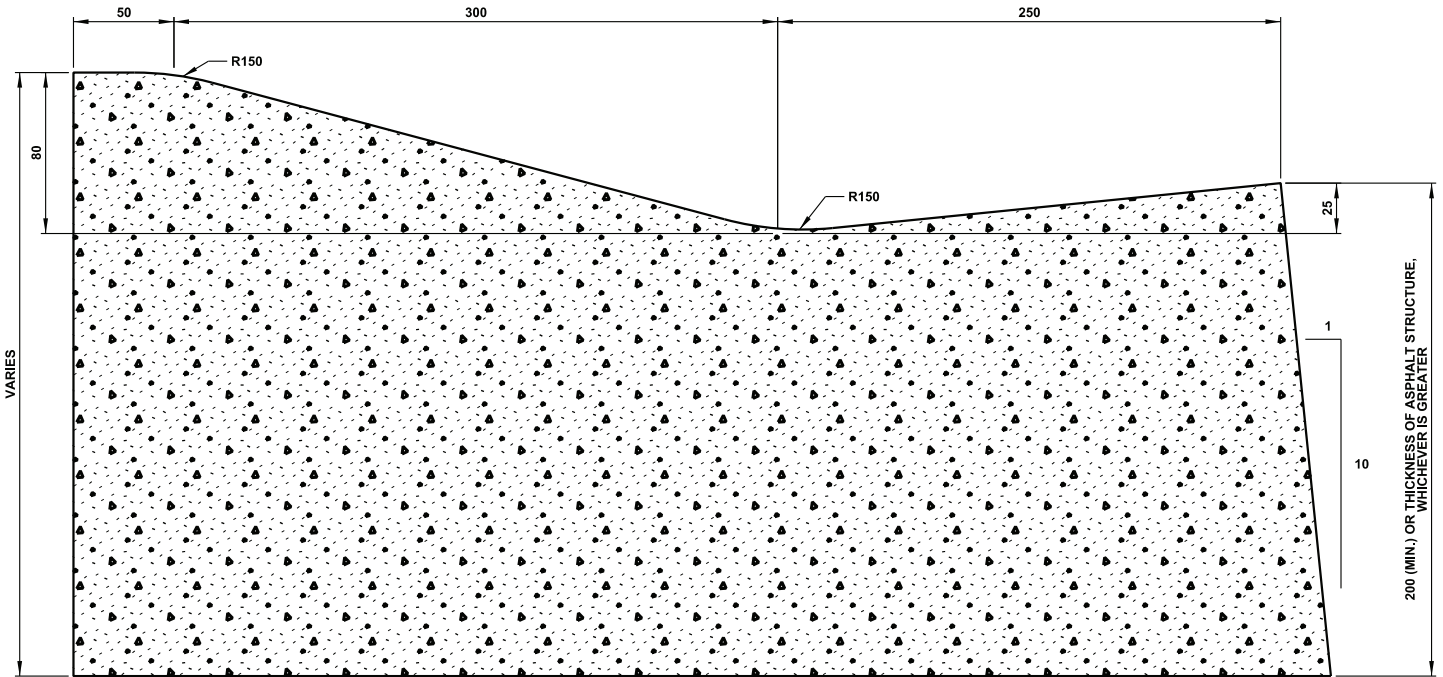

VARIABLES

200 (MIN.) OR THICKNESS OF ASPHALT STRUCTURE, WHICHEVER IS GREATER

ALL DIMENSIONS IN MILLIMETRES UNLESS OTHERWISE NOTED



STANDARD DRAWING

80mm ROLLED MOUNTABLE FACE CURB AND 250mm GUTTER

DATE APPROVED: 2018

DRAWN BY: KSYC

APPROVED: *M.A.R.*

DRAWING NUMBER: 5024

SCALE: N.T.S.

CHECKED BY: JN

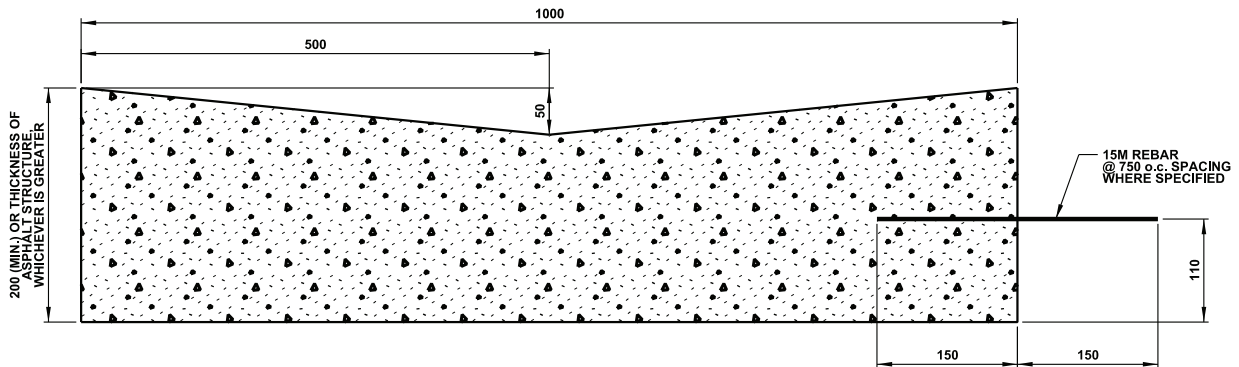

1000mm CONCRETE V-GUTTERS

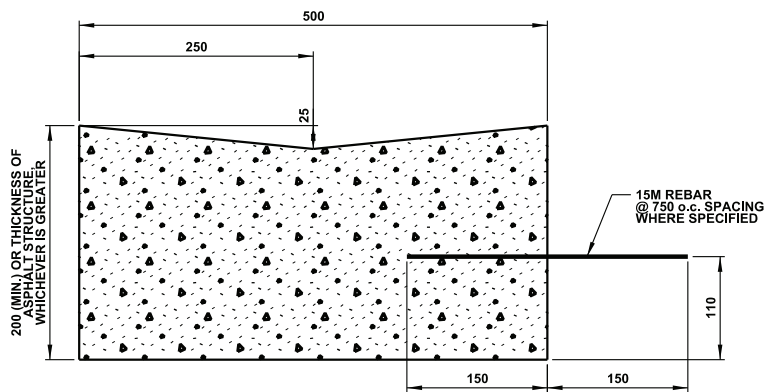

500mm CONCRETE V-GUTTERS

NOTES:

1. IF APPLICABLE, REBAR TO BE DOWELLED INTO NEIGHBOURING STRUCTURE.

**ALL DIMENSIONS
IN MILLIMETRES UNLESS
OTHERWISE NOTED**

500mm / 1000mm CONCRETE V-GUTTERS



STANDARD DRAWING

DATE APPROVED: **2018**

DRAWN BY: **KSYC**

APPROVED: *M.A.R.*

DRAWING NUMBER: **5030**

SCALE: **N.T.S.**

CHECKED BY: **JN**

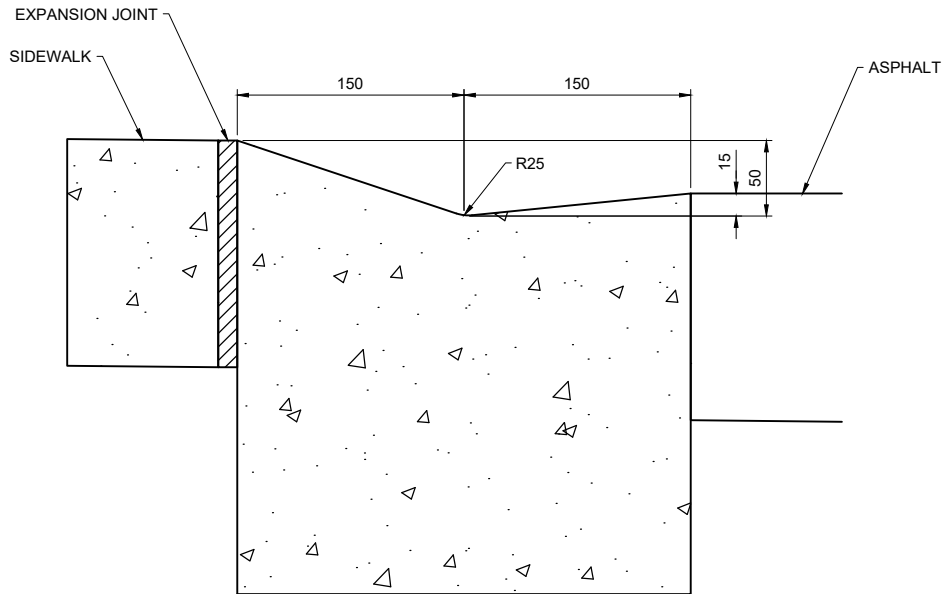

BEVELLED CURB WITH GUTTER

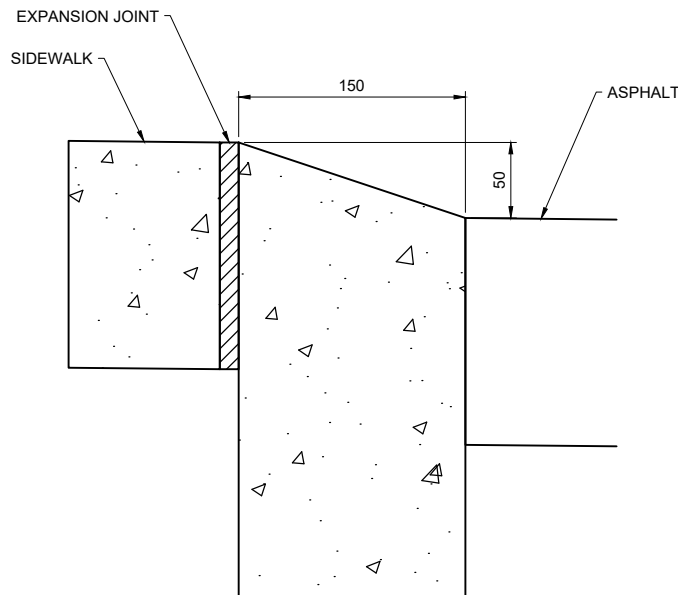

BEVELLED CURB WITHOUT GUTTER

NOTE:

- 1. REBAR TO BE DOWELLED INTO ADJACENT SIDEWALK STRUCTURE

**ALL DIMENSIONS
IN METRES UNLESS
OTHERWISE NOTED**

STANDARD DRAWING

BEVELLED CURB

DATE APPROVED: **2025**

SCALE: **N.T.S.**

DRAWN BY: **FR**

CHECKED BY: **JN**

APPROVED: *[Signature]*

DRAWING NUMBER: **5035**

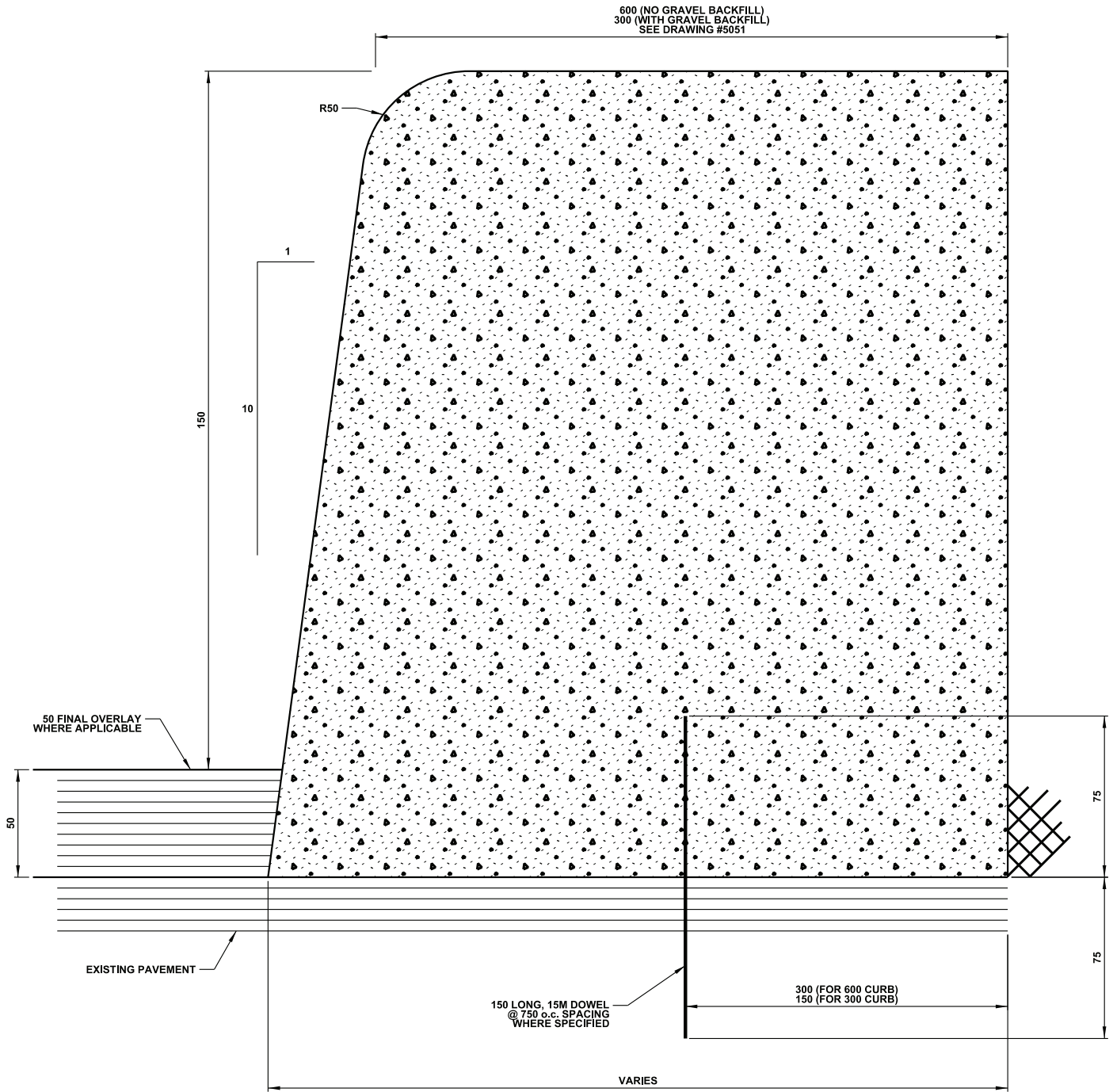

NOTES:

1. EXPOSED FACE OF CURB TO BE 150mm.
2. THIS METHOD OF CONSTRUCTION CANNOT BE USED UNLESS AUTHORIZED BY CITY OF EDMONTON.

**ALL DIMENSIONS
IN MILLIMETRES UNLESS
OTHERWISE NOTED**



CONCRETE BARRIER CURB

DATE APPROVED: **2018**

SCALE: **N.T.S.**

DRAWN BY: **KSYC**

CHECKED BY: **JN**

APPROVED: *M.R.*

DRAWING NUMBER: **5040**

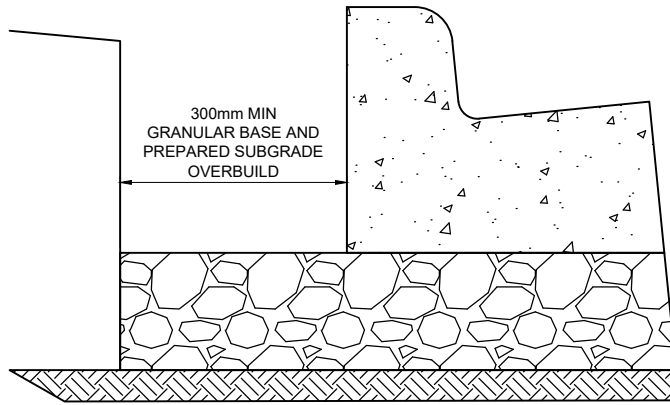

OVERBUILD DETAIL - CURBS

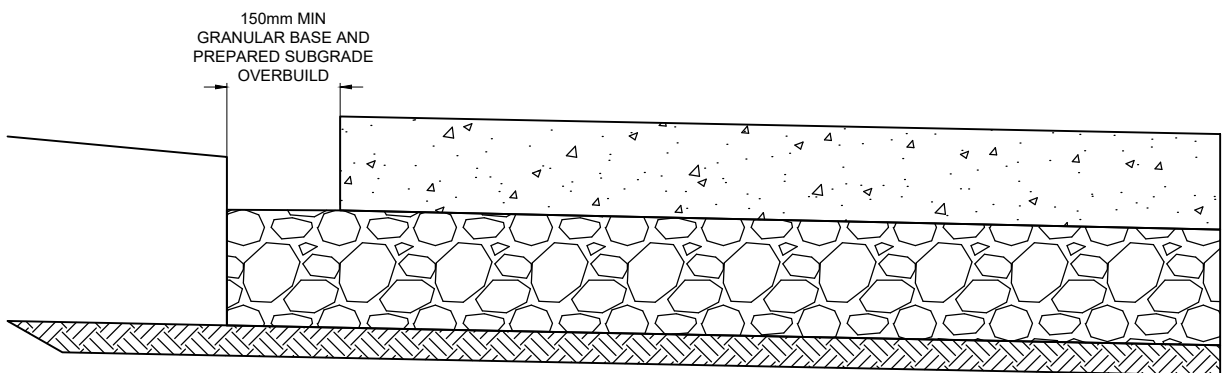

OVERBUILD DETAIL - SIDEWALKS AND TRAILS

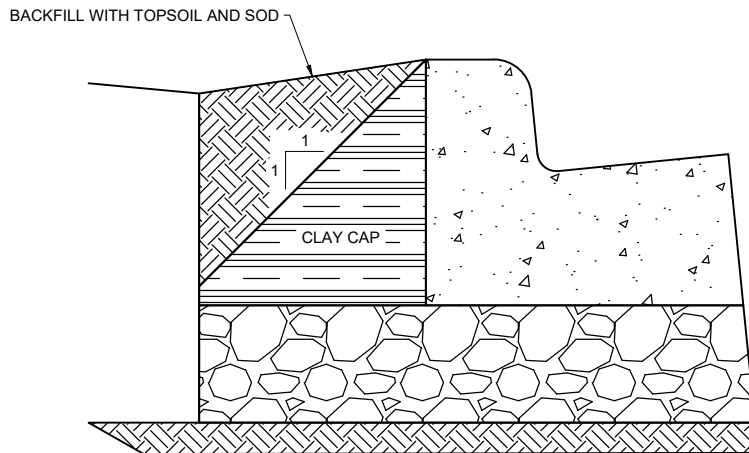

BACKFILL DETAIL

**ALL DIMENSIONS
IN METRES UNLESS
OTHERWISE NOTED**

OVERBUILD AND BACKFILL DETAILS



STANDARD DRAWING

DATE APPROVED: **2025**

DRAWN BY: **FR**

APPROVED: *[Signature]*

DRAWING NUMBER: **5045**

SCALE: **N.T.S.**

CHECKED BY: **JN**

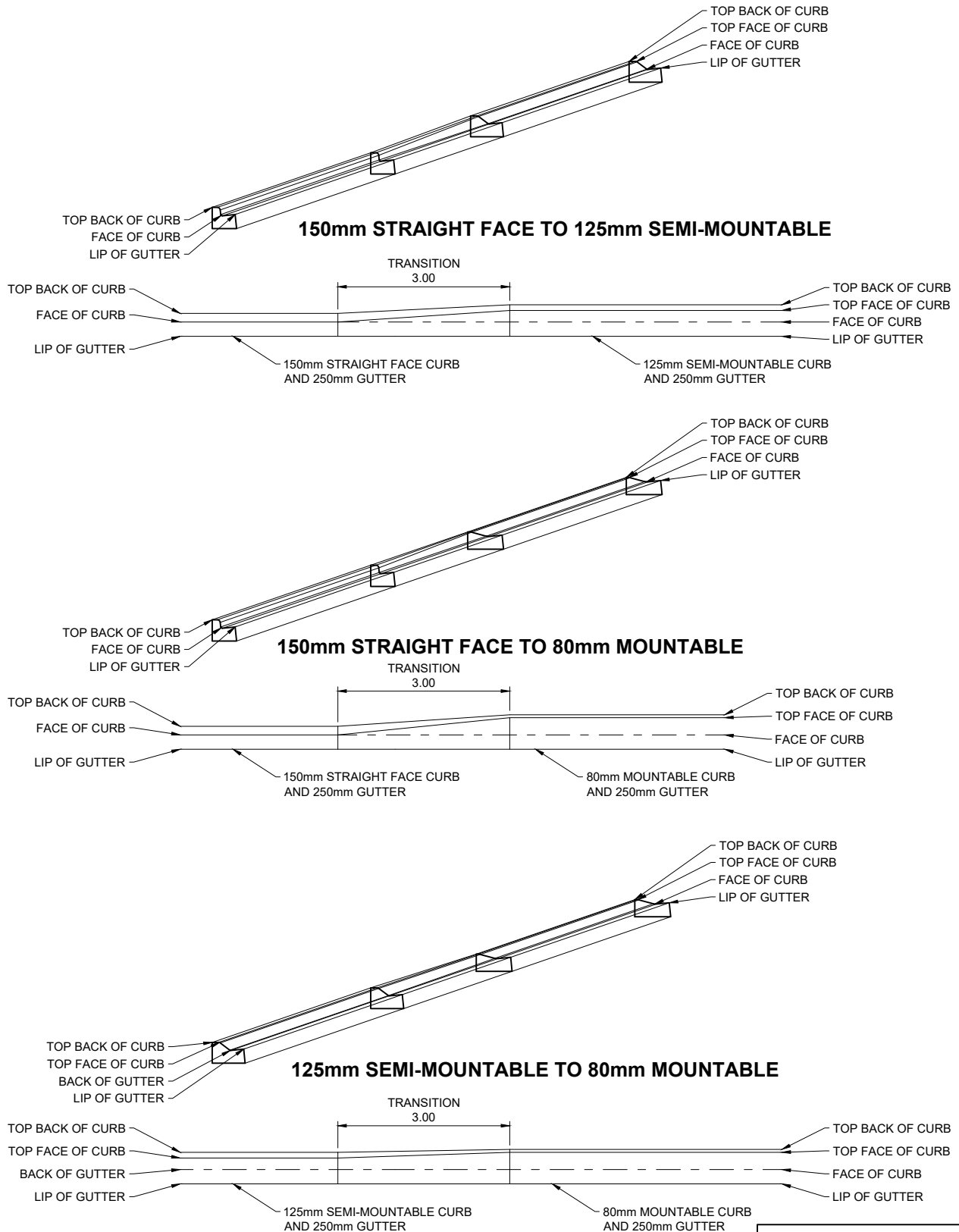

**ALL DIMENSIONS
IN METRES UNLESS
OTHERWISE NOTED**

CURB TRANSITIONS



STANDARD DRAWING

DATE APPROVED: **2025**

DRAWN BY: **FR**

APPROVED: *[Signature]*

DRAWING NUMBER: **5046**

SCALE: **N.T.S.**

CHECKED BY: **JN**

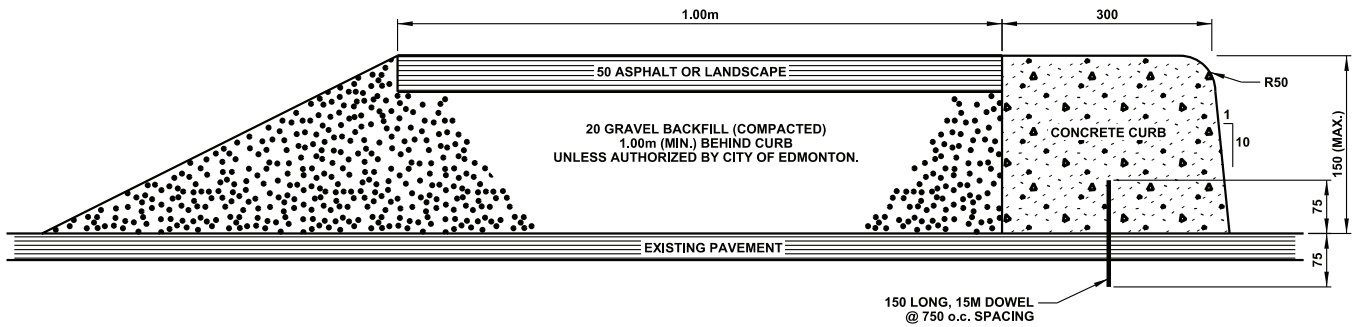
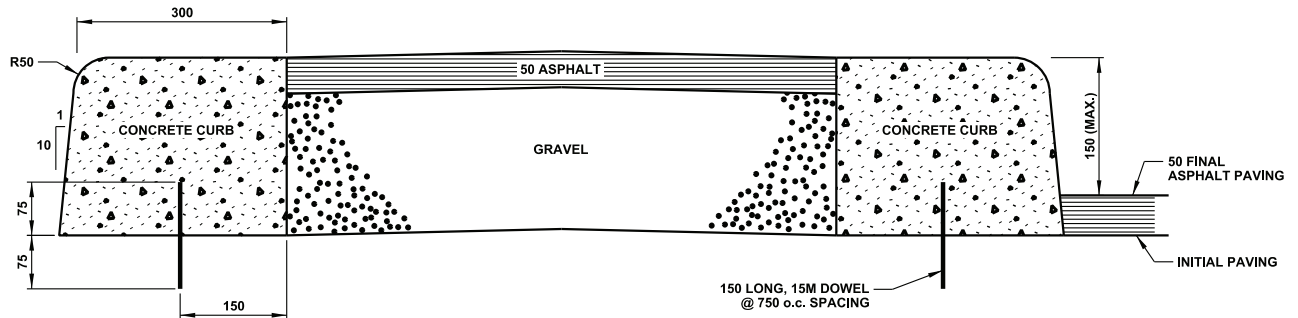

NOTES:

1. MAXIMUM EXPOSED FACE OR CURB TO BE 150mm.
2. INCREASE WIDTH OF CONCRETE CURB TO 600 IF NO GRAVEL BACKFILL AND ASPHALT TOPPING.
3. CONCRETE CURB DETAIL SEE DRAWING #5040.

**ALL DIMENSIONS
IN MILLIMETERS UNLESS
OTHERWISE NOTED**



STANDARD DRAWING

TEMPORARY SLAB-ON CONCRETE CURB

DATE APPROVED: **2018**

SCALE: **N.T.S.**

DRAWN BY: **KSYC**

CHECKED BY: **JN**

APPROVED: *M.A.R.*

DRAWING NUMBER: **5051**

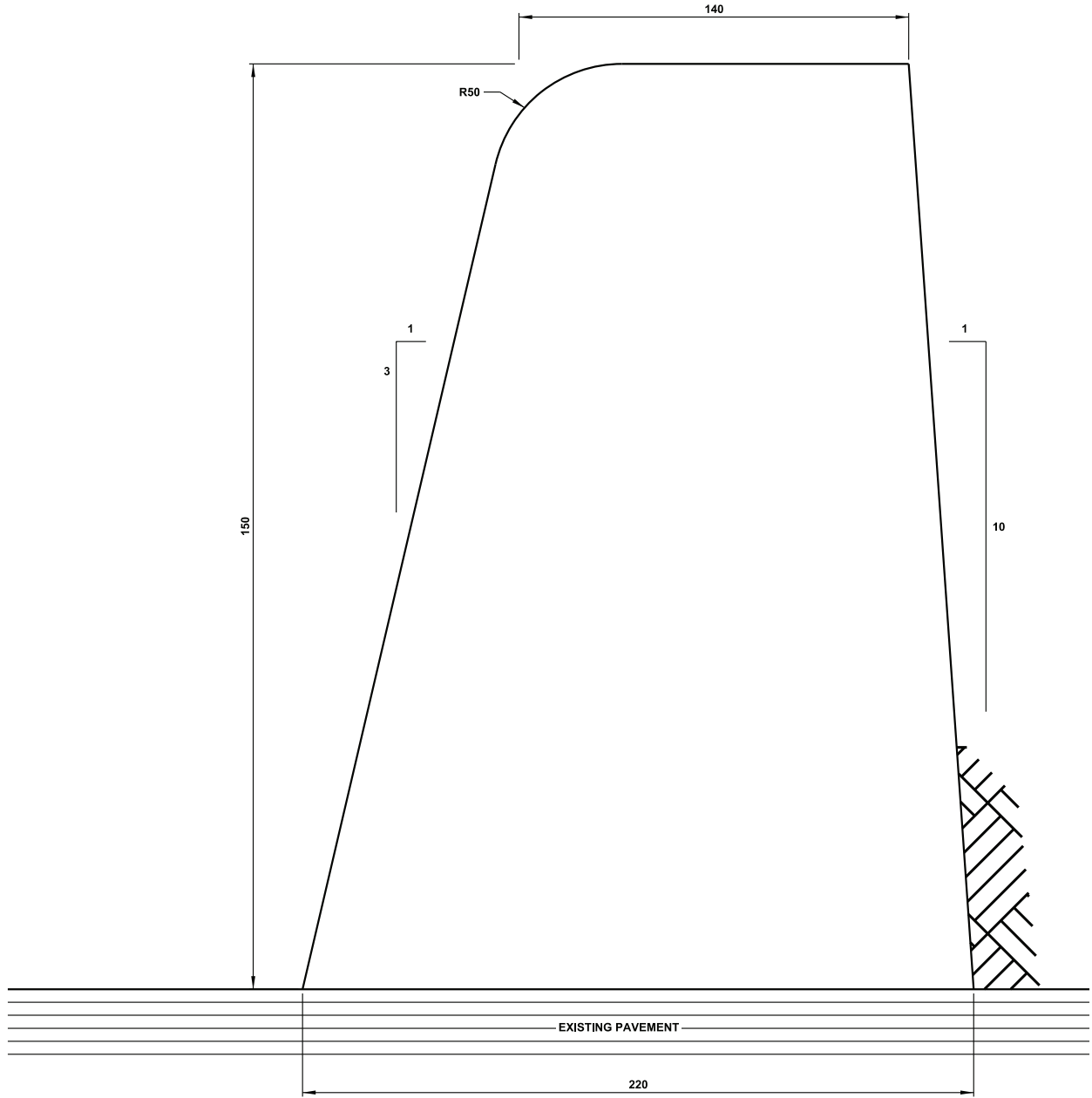

**ALL DIMENSIONS
IN MILLIMETRES UNLESS
OTHERWISE NOTED**

TEMPORARY SLAB-ON ASPHALT CURB



STANDARD DRAWING

DATE APPROVED: **2018**

DRAWN BY: **KSYC**

APPROVED: *M.A.R.*

DRAWING NUMBER: **5052**

SCALE: **N.T.S.**

CHECKED BY: **JN**

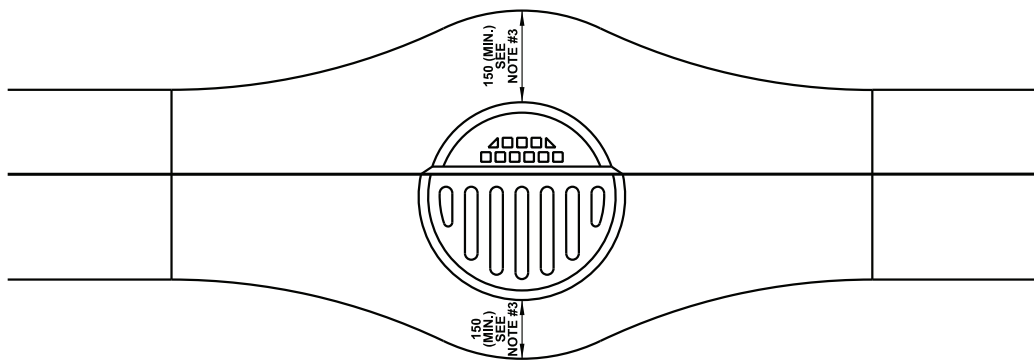
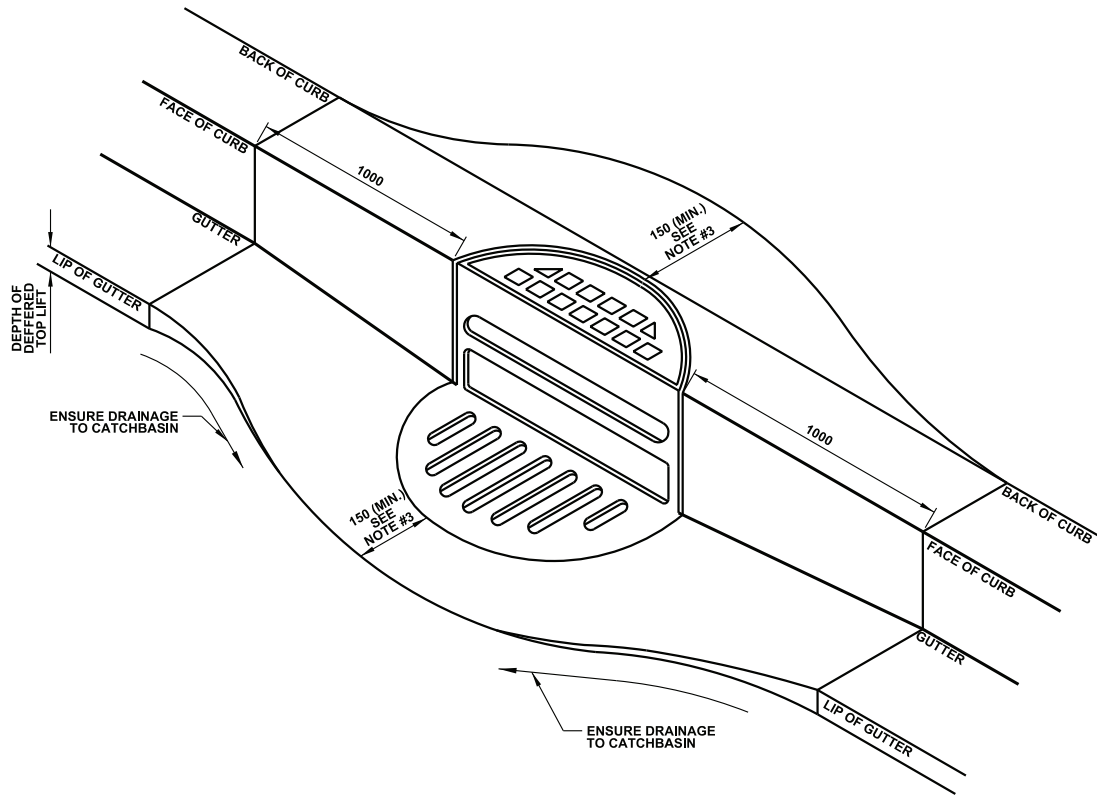

PLAN VIEW

NOTES:

1. TYPICAL CURB AND GUTTER TREATMENT AT CATCHBASIN WHEN ASPHALT TOP LIFT IS DEFERRED. LOCATION TO BE DETERMINED BY ENGINEER.
2. 0.50% (MIN.) FOR 5.00m EACH DIRECTION ON SAG VERTICAL CURVE.
3. MINIMUM OFFSET DISTANCE FROM EDGE OF CURB TO CATCHBASIN ARE MEASURED FROM EDGE OF CATCHBASIN BARREL / RINGS. SEE CITY OF EDMONTON DESIGN STANDARD CHAPTER 3 DRAINAGE DRAWINGS.

**ALL DIMENSIONS
IN MILLIMETRES UNLESS
OTHERWISE NOTED**



STANDARD DRAWING

DEPRESSED CURB AND GUTTER FOR CATCHBASIN

DATE APPROVED: **2018**

SCALE: **N.T.S.**

DRAWN BY: **KSYC**

CHECKED BY: **JN**

APPROVED: *M.A.R.*

DRAWING NUMBER: **5060**

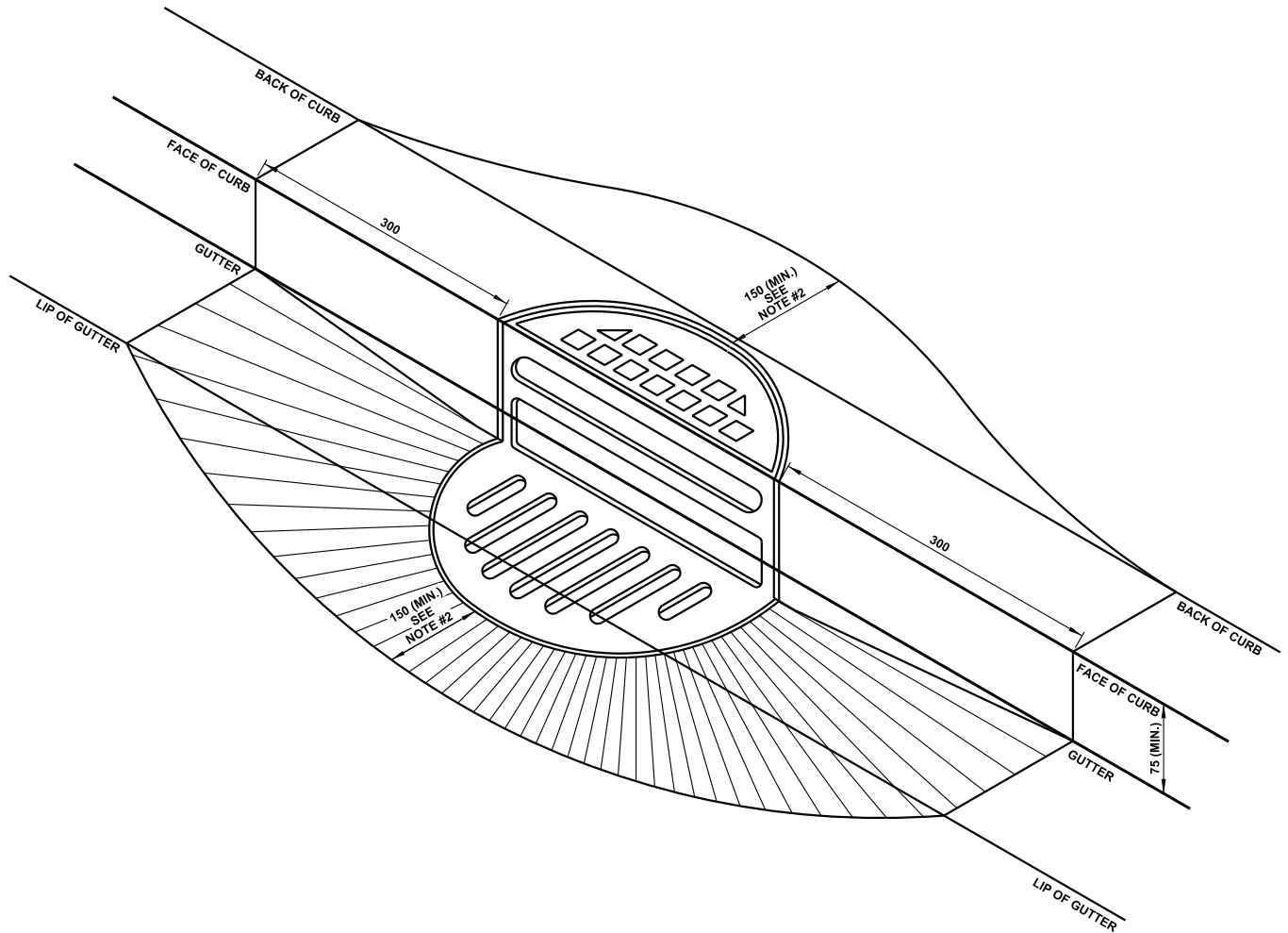

NOTES:

- 1. TYPICAL ASPHALT GRADING AROUND CATCH BASINS WITH 50.00 OVERLAYS IN GUTTERS.

**ALL DIMENSIONS
IN MILLIMETRES UNLESS
OTHERWISE NOTED**



STANDARD DRAWING

CATCHBASIN TREATMENT 50mm OVERLAY OF GUTTER

DATE APPROVED: **2018**
SCALE: **N.T.S.**

DRAWN BY: **KSYC**
CHECKED BY: **JN**

APPROVED: *M.A.R.*

DRAWING NUMBER: **5061**

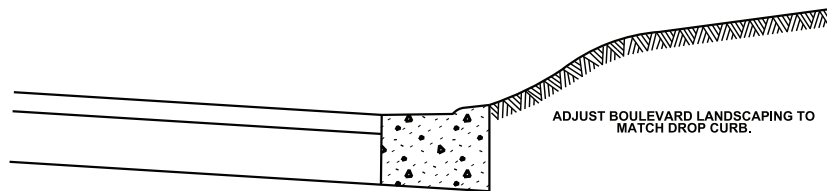
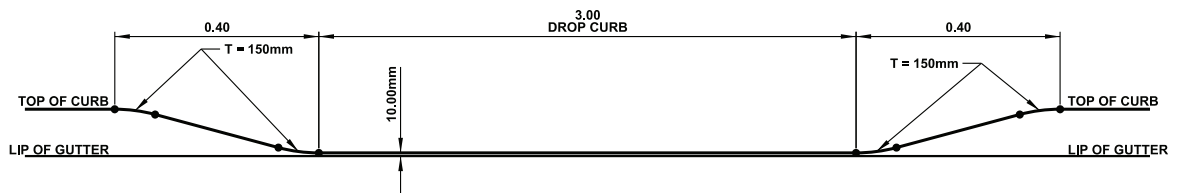
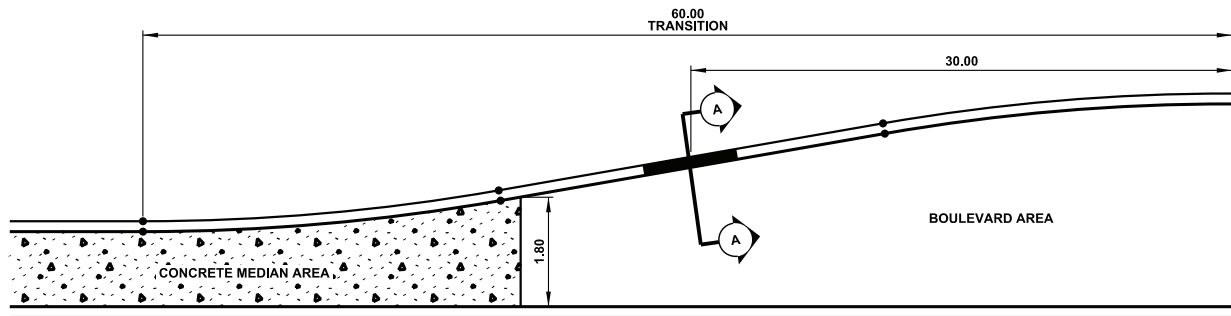

CROSS SECTION A-A

**ALL DIMENSIONS
IN METRES UNLESS
OTHERWISE NOTED**

LAWN MOWER ACCESS TO MEDIAN



STANDARD DRAWING

DATE APPROVED: 2018

DRAWN BY: KSYC

APPROVED: *M.R.*

DRAWING NUMBER: 5070

SCALE: N.T.S.

CHECKED BY: JN

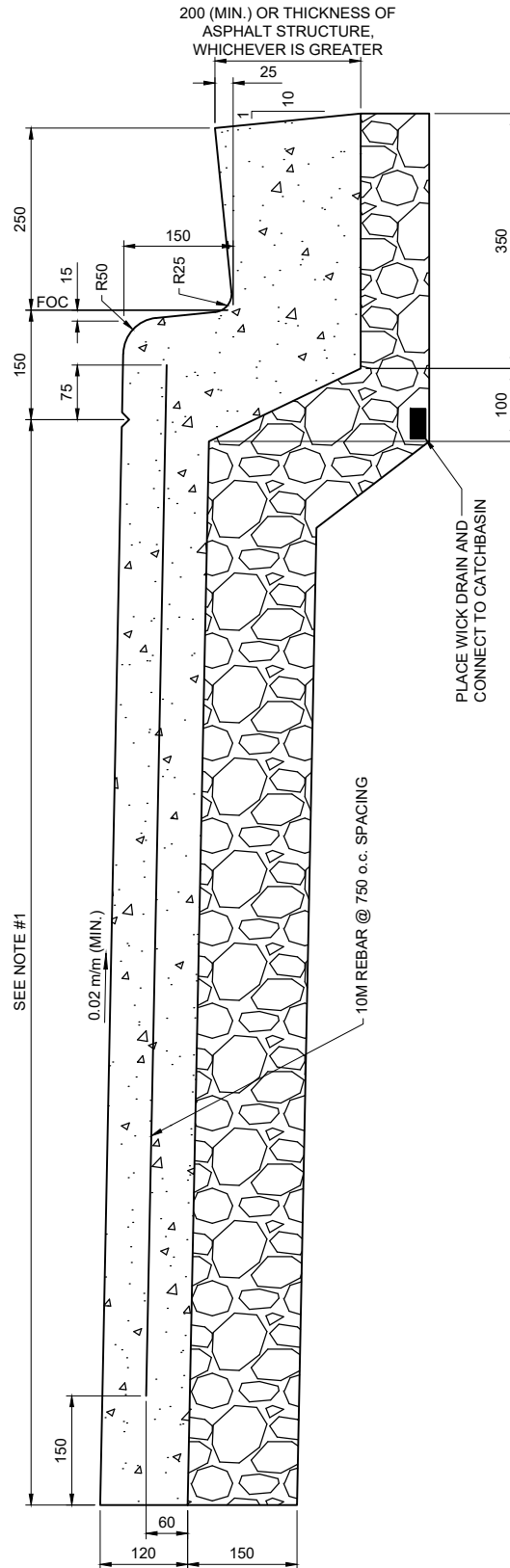

NOTE:

- MINIMUM WIDTH OF MONOWALK
 - ON URBAN LOCAL ROADWAYS TO BE 1.80m.
 - ALONG COLLECTOR / ARTERIAL ROADWAYS TO BE 2.30m IN RETROFIT.
 - IN FRONT OF SCHOOL SITE TO BE 2.50m.

**ALL DIMENSIONS
IN MILLIMETRES UNLESS
OTHERWISE NOTED**



STANDARD DRAWING

MONOLITHIC WALK WITH 150mm CURB AND 250mm GUTTER

DATE APPROVED: **2025**

DRAWN BY: **FR**

APPROVED: *[Signature]*

DRAWING NUMBER: **5100**

SCALE: **N.T.S.**

CHECKED BY: **JN**

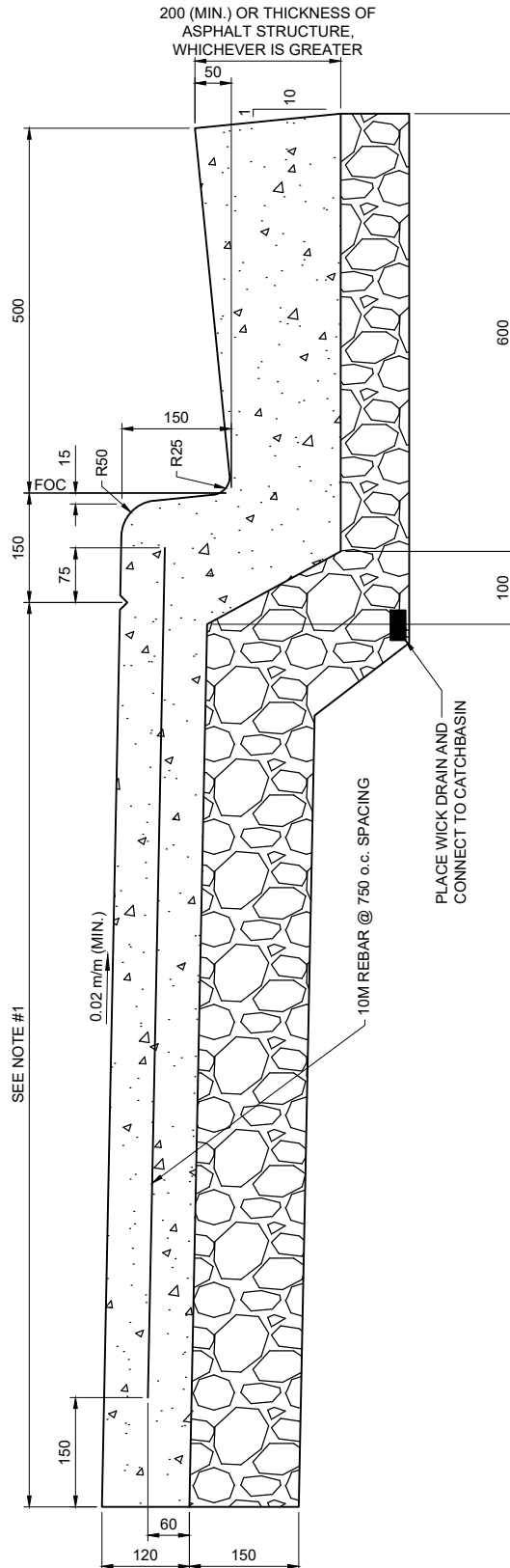

- NOTE:
- MINIMUM WIDTH OF MONOWALK
 - ON URBAN LOCAL ROADWAYS TO BE 1.80m.
 - ALONG COLLECTOR / ARTERIAL ROADWAYS TO BE 2.30m IN RETROFIT.
 - IN FRONT OF SCHOOL SITE TO BE 2.50m.

**ALL DIMENSIONS
IN MILLIMETRES UNLESS
OTHERWISE NOTED**



MONOLITHIC WALK WITH 150mm CURB AND 500mm GUTTER (RETROFIT)

DATE APPROVED: **2025**
SCALE: **N.T.S.**

DRAWN BY: **FR**
CHECKED BY: **JN**

APPROVED: *[Signature]*

DRAWING NUMBER: **5110**

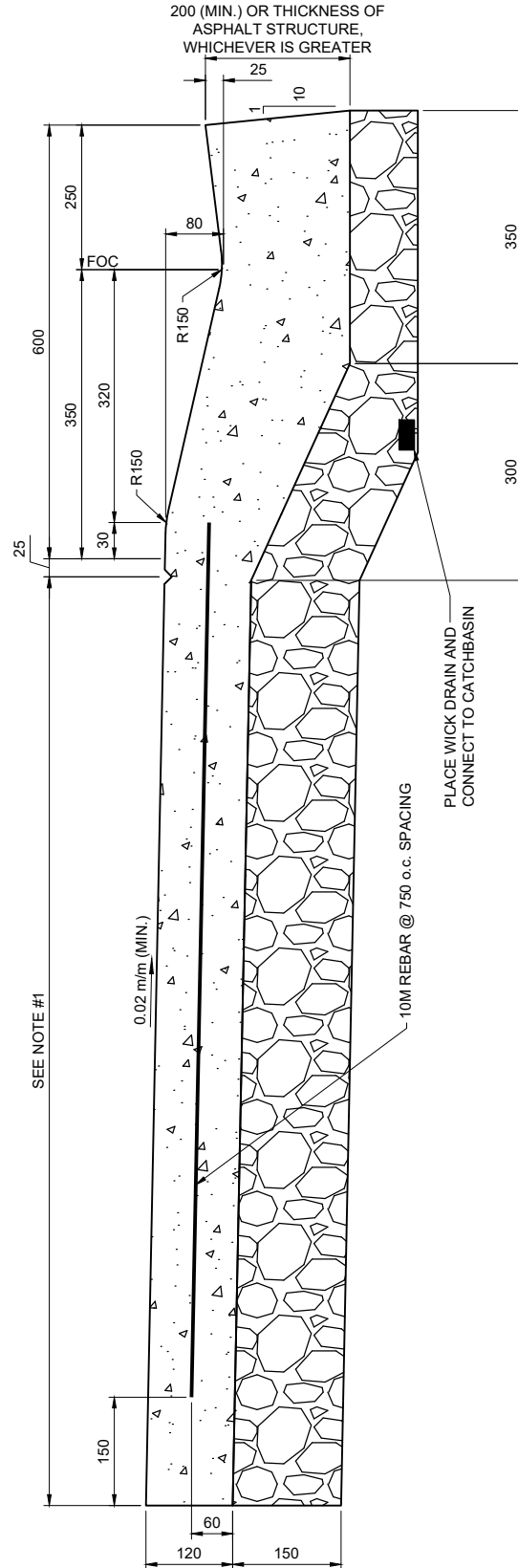

NOTE:

- 1. MINIMUM WIDTH OF MONOWALK
 - ON URBAN LOCAL ROADWAYS TO BE 1.80m.
 - ALONG COLLECTOR / ARTERIAL ROADWAYS TO BE 2.30m IN RETROFIT.
 - IN FRONT OF SCHOOL SITE TO BE 2.50m.

**ALL DIMENSIONS
IN MILLIMETRES UNLESS
OTHERWISE NOTED**

STANDARD DRAWING

ROLLED FACE MONOLITHIC WALK AND GUTTER

DATE APPROVED: **2025**
SCALE: **N.T.S.**

DRAWN BY: **FR**
CHECKED BY: **JN**

APPROVED: *[Signature]*

DRAWING NUMBER: **5120**

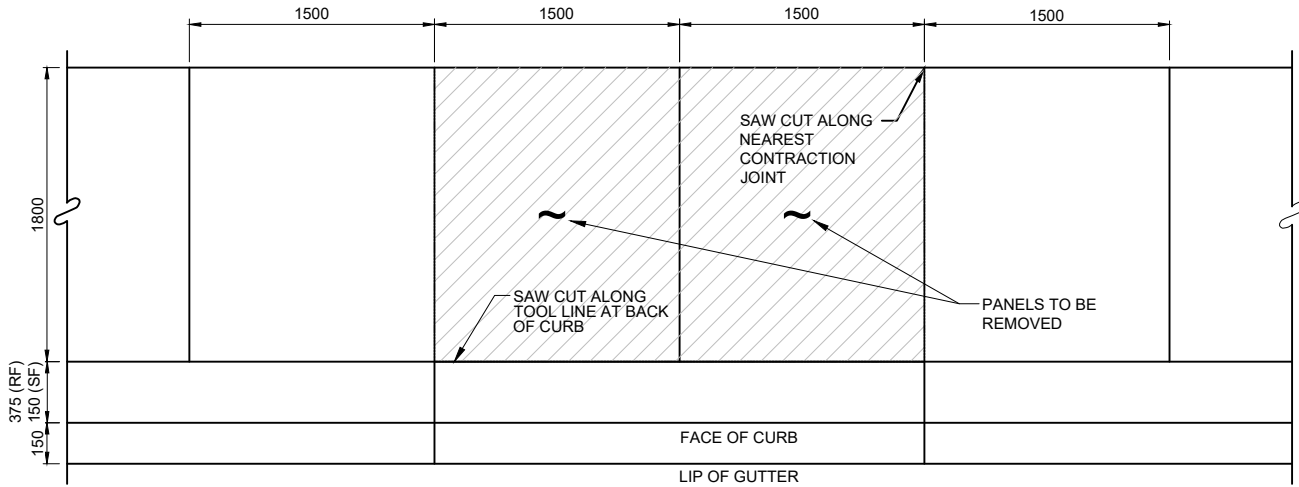

TYPICAL PLAN VIEW - SAW CUT & REMOVAL

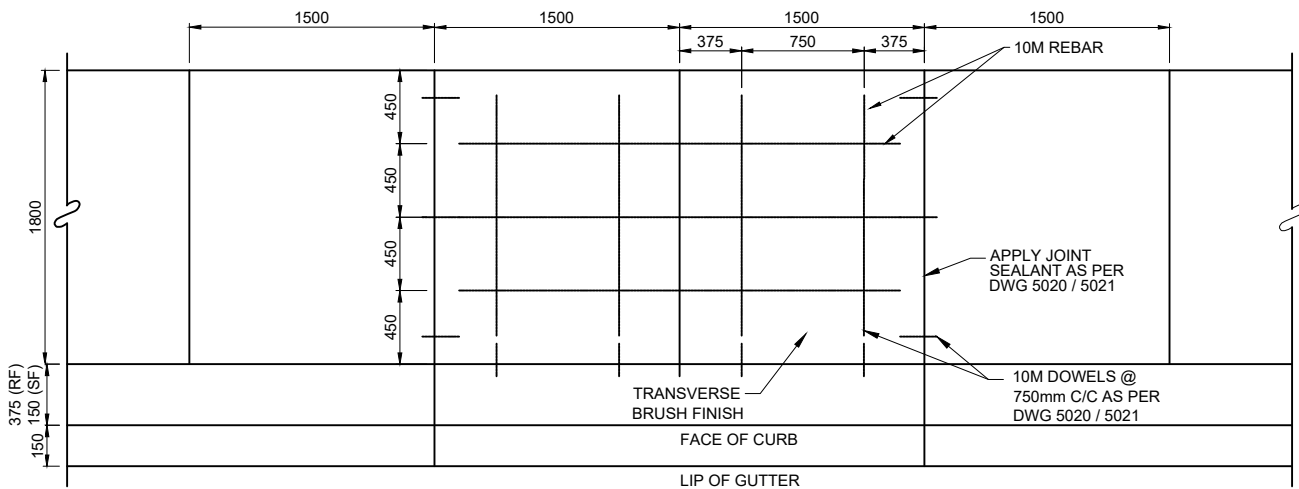

TYPICAL PLAN VIEW - REPLACEMENT PANELS

NOTE:

1. ALTERNATE CONTRACTION JOINT AND SURFACE JOINT FOR TYPICAL CONCRETE WALKWAY CONSTRUCTION.
2. LONGITUDINAL REBARS MUST BE CONTINUOUS AND TIED TO THE TRANSVERSE REBARS.

**ALL DIMENSIONS
IN MILLIMETRES UNLESS
OTHERWISE NOTED**

**CONCRETE MONOWALK PANEL
REPLACEMENT - 1.80m**



STANDARD DRAWING

DATE APPROVED: **2025**

DRAWN BY: **NH**

APPROVED:

DRAWING NUMBER: **5125**

SCALE: **N.T.S.**

CHECKED BY: **JN**

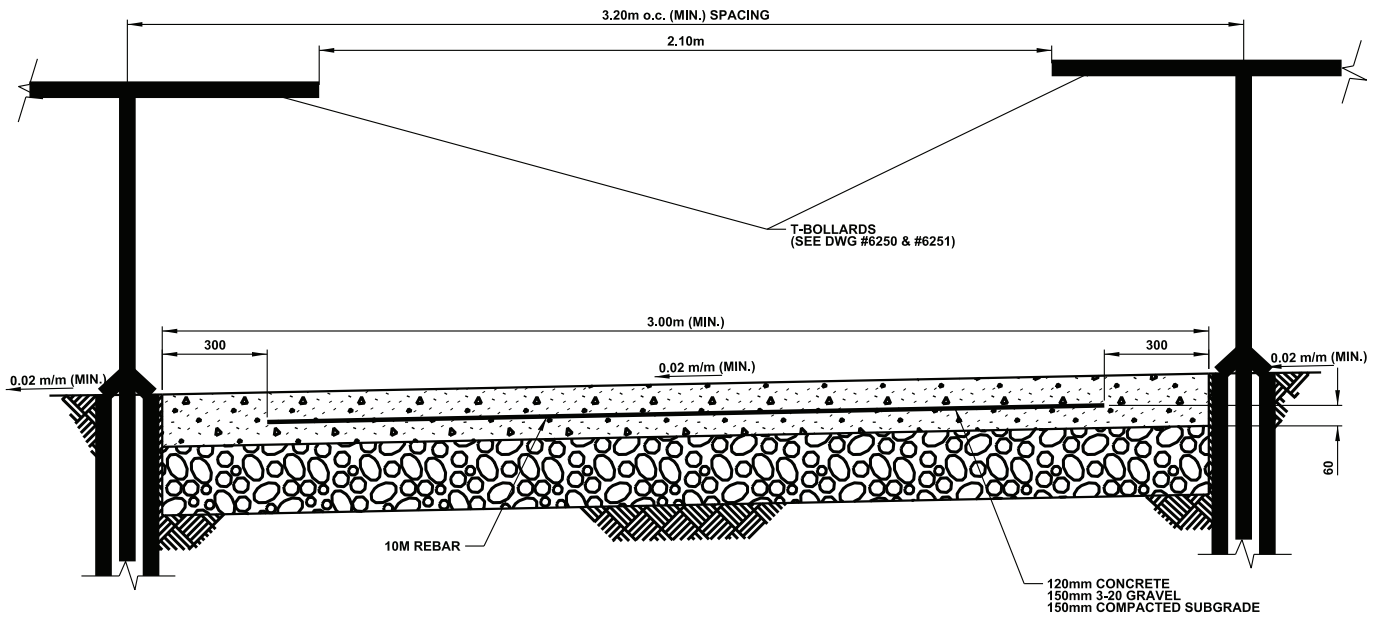

TYPICAL SECTION

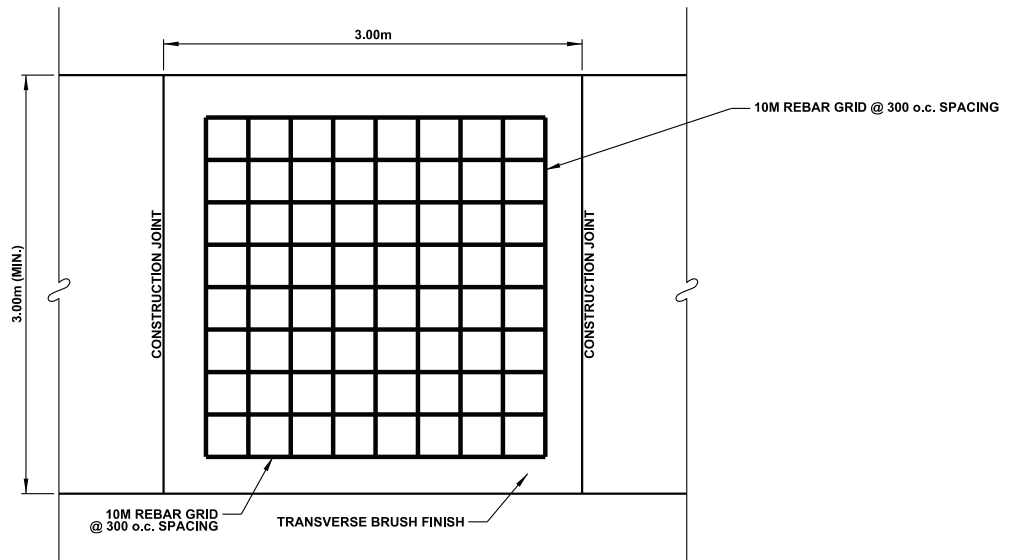

PLAN VIEW

NOTES:

1. T-BOLLARDS REQUIREMENT ARE UNDER DISCRETION OF CITY OF EDMONTON.
2. WIRE MESH WILL NOT BE CONSIDERED AS AN ALTERNATIVE.

**ALL DIMENSIONS
IN MILLIMETRES UNLESS
OTHERWISE NOTED**



STANDARD DRAWING

**EMERGENCY ACCESS ROAD
CONCRETE**

DATE APPROVED: **2018**

DRAWN BY: **KSYC**

APPROVED: *M.R.*

DRAWING NUMBER: **5130**

SCALE: **N.T.S.**

CHECKED BY: **JN**

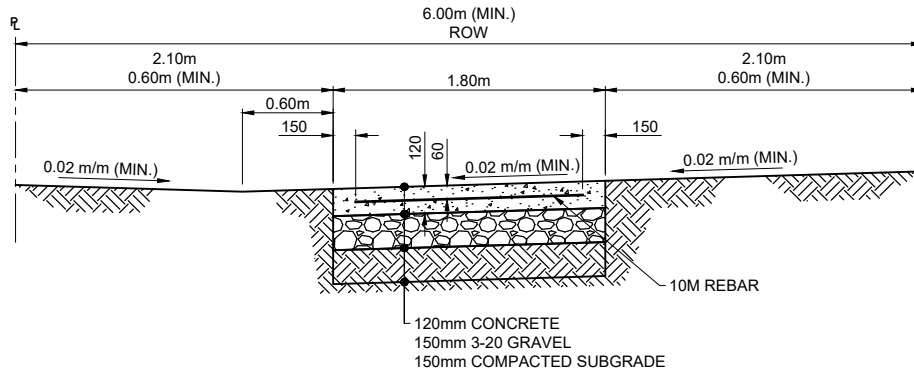

TYPICAL SECTION

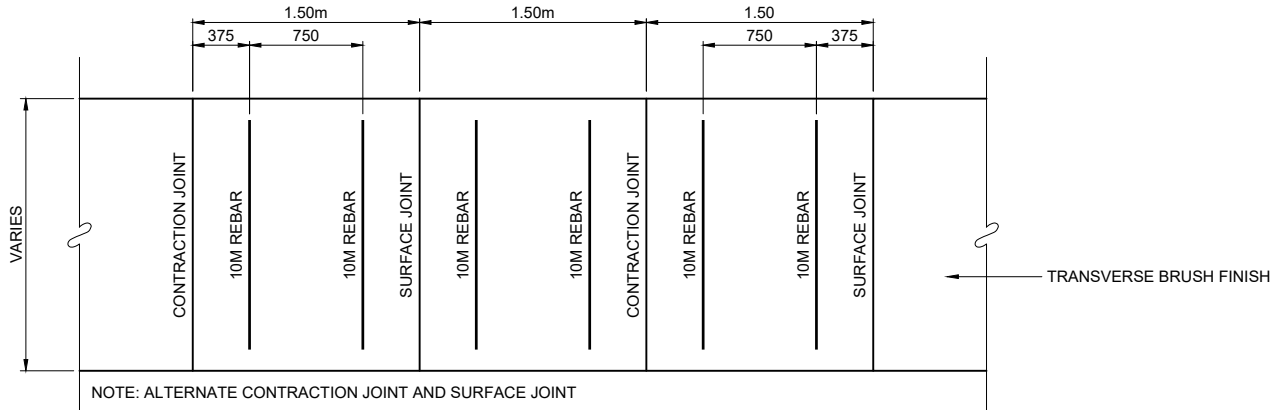

NOTE: ALTERNATE CONTRACTION JOINT AND SURFACE JOINT

TYPICAL PLAN VIEW

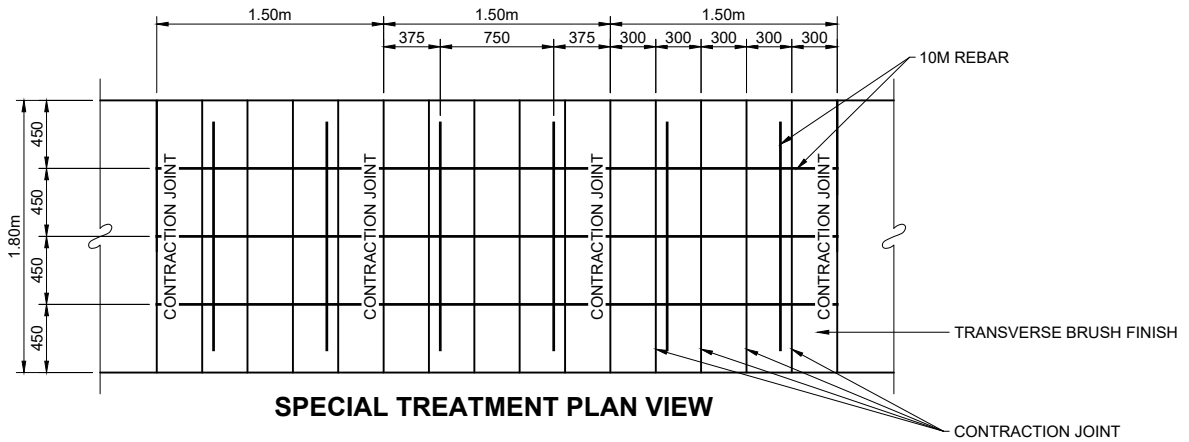

SPECIAL TREATMENT PLAN VIEW

NOTE:

1. ALTERNATE CONTRACTION JOINT AND SURFACE JOINT FOR TYPICAL CONCRETE CONNECTOR WALKWAY CONSTRUCTION.
2. SPECIAL TREATMENT ADJACENT TO EXISTING TREES AS REQUESTED BY ENGINEER.
3. USE ALL CONTRACTION JOINTS WITHIN SPECIAL TREATMENT AREA.
4. LONGITUDINAL REBARS MUST BE CONTINUOUS AND TIED TO THE TRANSVERSE REBARS.

**ALL DIMENSIONS
IN MILLIMETRES UNLESS
OTHERWISE NOTED**



STANDARD DRAWING

CONCRETE WALKWAY - 1.80m

DATE APPROVED: **2025**
SCALE: **N.T.S.**

DRAWN BY: **FR**
CHECKED BY: **JN**

APPROVED: 

DRAWING NUMBER: **5140**

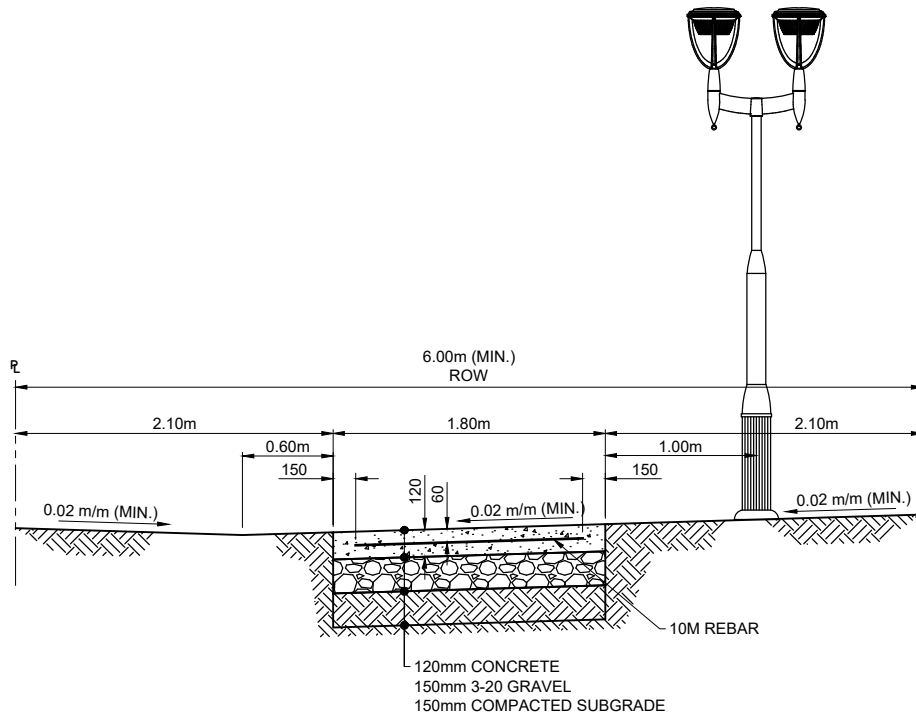

TYPICAL SECTION

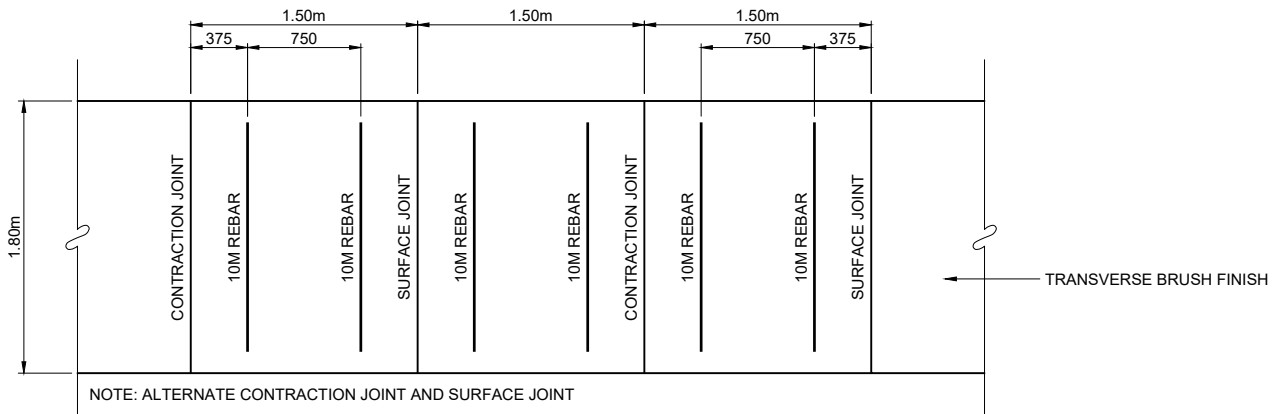

TYPICAL PLAN VIEW

NOTE:

1. ALTERNATE CONTRACTION JOINT AND SURFACE JOINT FOR TYPICAL CONCRETE CONNECTOR WALKWAY CONSTRUCTION.

**ALL DIMENSIONS
IN MILLIMETRES UNLESS
OTHERWISE NOTED**

STANDARD DRAWING

CONCRETE WALKWAY FOR REVERSE HOUSING - 1.80m IN 6.00m ROW

DATE APPROVED: **2025**
SCALE: **N.T.S.**

DRAWN BY: **FR**
CHECKED BY: **JN**

APPROVED: *[Signature]*

DRAWING NUMBER: **5145**

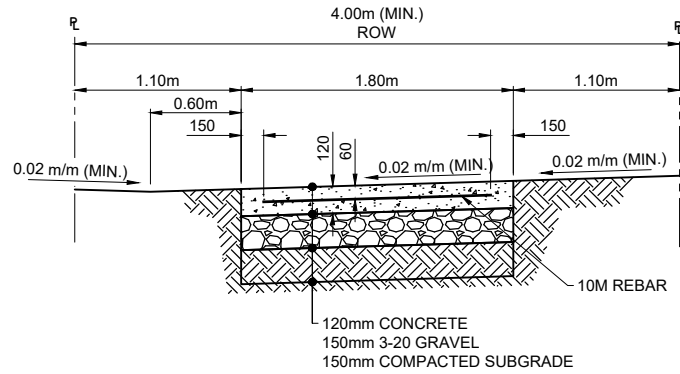

TYPICAL SECTION

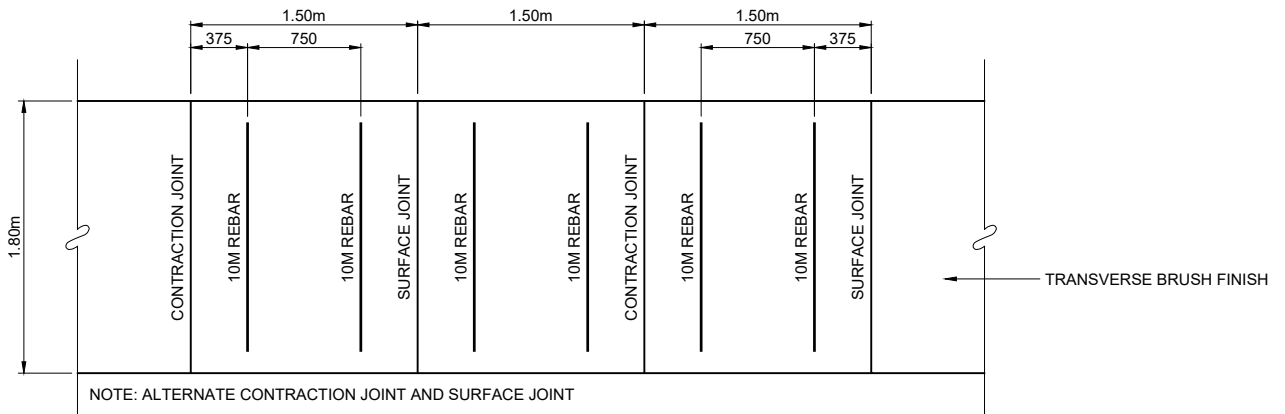

NOTE: ALTERNATE CONTRACTION JOINT AND SURFACE JOINT

TYPICAL PLAN VIEW

NOTE:

1. ALTERNATE CONTRACTION JOINT AND SURFACE JOINT FOR TYPICAL CONCRETE CONNECTOR WALKWAY CONSTRUCTION.

**ALL DIMENSIONS
IN MILLIMETRES UNLESS
OTHERWISE NOTED**



STANDARD DRAWING

CONCRETE WALKWAY FOR REVERSE HOUSING - 1.80m IN 4.00m ROW

DATE APPROVED: **2025**
SCALE: **N.T.S.**

DRAWN BY: **FR**
CHECKED BY: **JN**

APPROVED: 

DRAWING NUMBER: **5146**

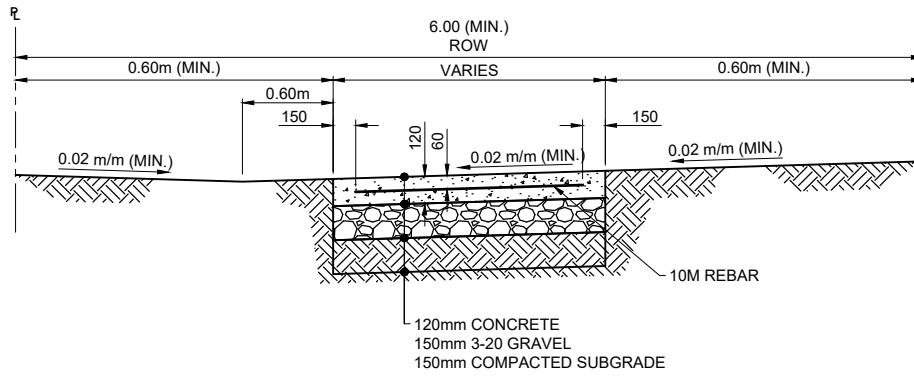

TYPICAL SECTION

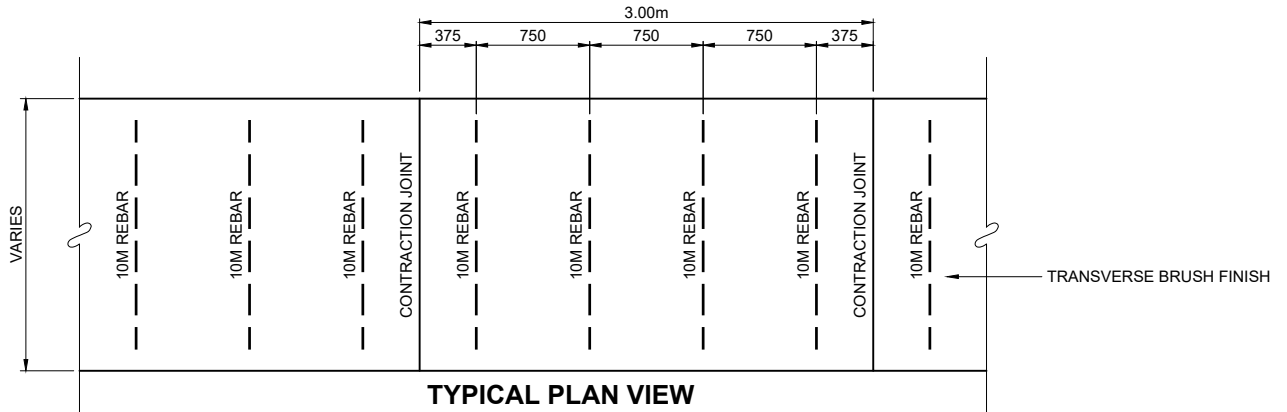

TYPICAL PLAN VIEW

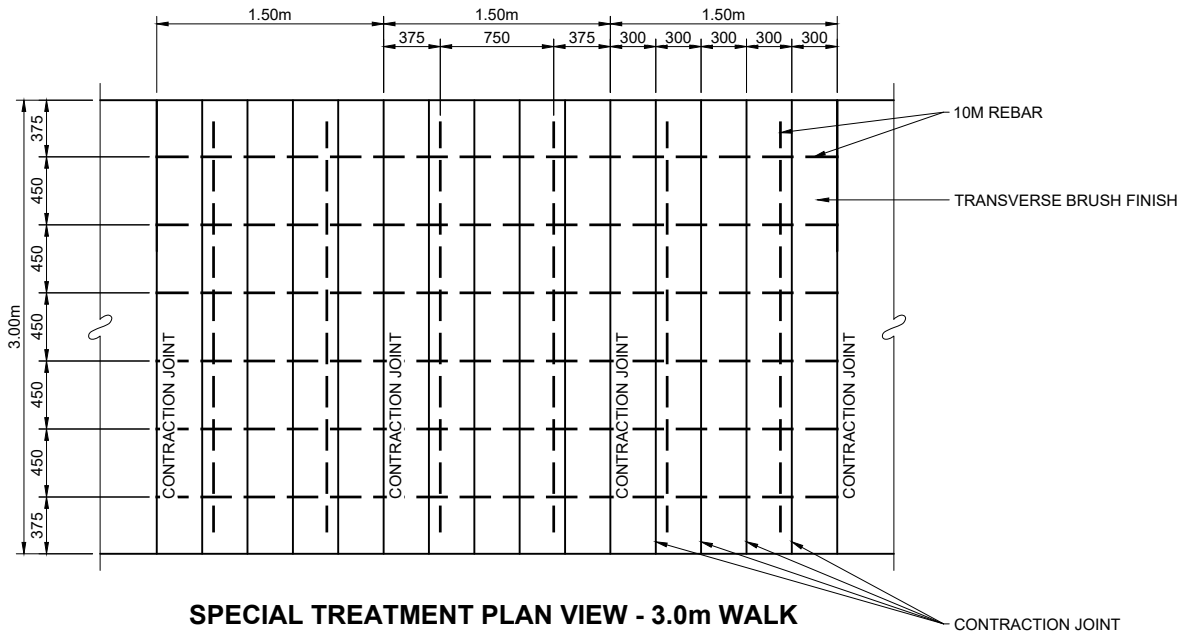

SPECIAL TREATMENT PLAN VIEW - 3.0m WALK

NOTE:

1. ALTERNATE CONTRACTION JOINT AND SURFACE JOINT FOR TYPICAL CONCRETE CONNECTOR WALKWAY CONSTRUCTION.
2. SPECIAL TREATMENT ADJACENT TO EXISTING TREES AS REQUESTED BY ENGINEER.
3. USE ALL CONTRACTION JOINTS WITHIN SPECIAL TREATMENT AREA.
4. LONGITUDINAL REBARS MUST BE CONTINUOUS AND TIED TO THE TRANSVERSE REBARS.

**ALL DIMENSIONS
IN MILLIMETRES UNLESS
OTHERWISE NOTED**

STANDARD DRAWING

CONCRETE WALKWAY / PATHWAY - GREATER THAN 1.80m

DATE APPROVED: **2025**

SCALE: **N.T.S.**

DRAWN BY: **FR**

CHECKED BY: **JN**

APPROVED: *[Signature]*

DRAWING NUMBER: **5150**

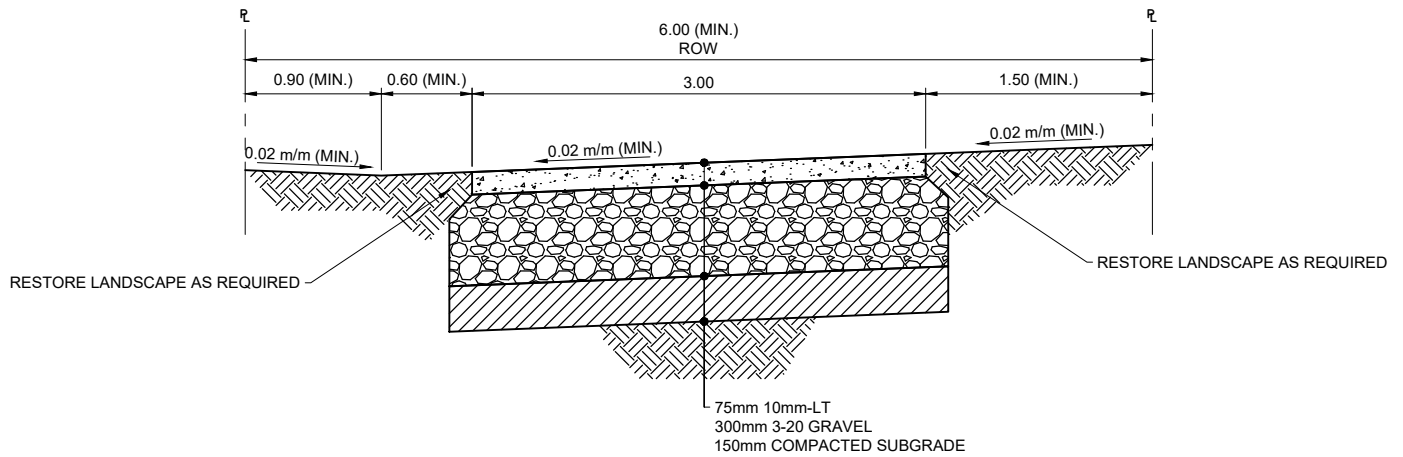

TYPICAL SECTION

ALTERNATE STRUCTURE:

- 75mm 10mm-LT
- 300mm 3-20 GRAVEL WRAPPED IN NON-WOVEN GEOTEXTILE UP TO EDGES OF EXCAVATION ON NATIVE GROUND

NOTE:

1. FOR 3.00m SHARED PATHWAY WIDTH, 100mm SOLID YELLOW CENTER LINE IS REQUIRED AT THE DISCRETION OF CITY OF EDMONTON
2. BREEZEWAY PATHWAY DETAIL ONLY APPLIES TO CONNECTIONS BETWEEN BLOCKS OF TWO OR LESS LOTS IN DEPTH

**ALL DIMENSIONS
IN METRES UNLESS
OTHERWISE NOTED**



STANDARD DRAWING

3.00m ASPHALT BREEZEWAY CONNECTION IN 6.00m ROW

DATE APPROVED: **2025**

DRAWN BY: **FR**

APPROVED: 

DRAWING NUMBER: **5155**

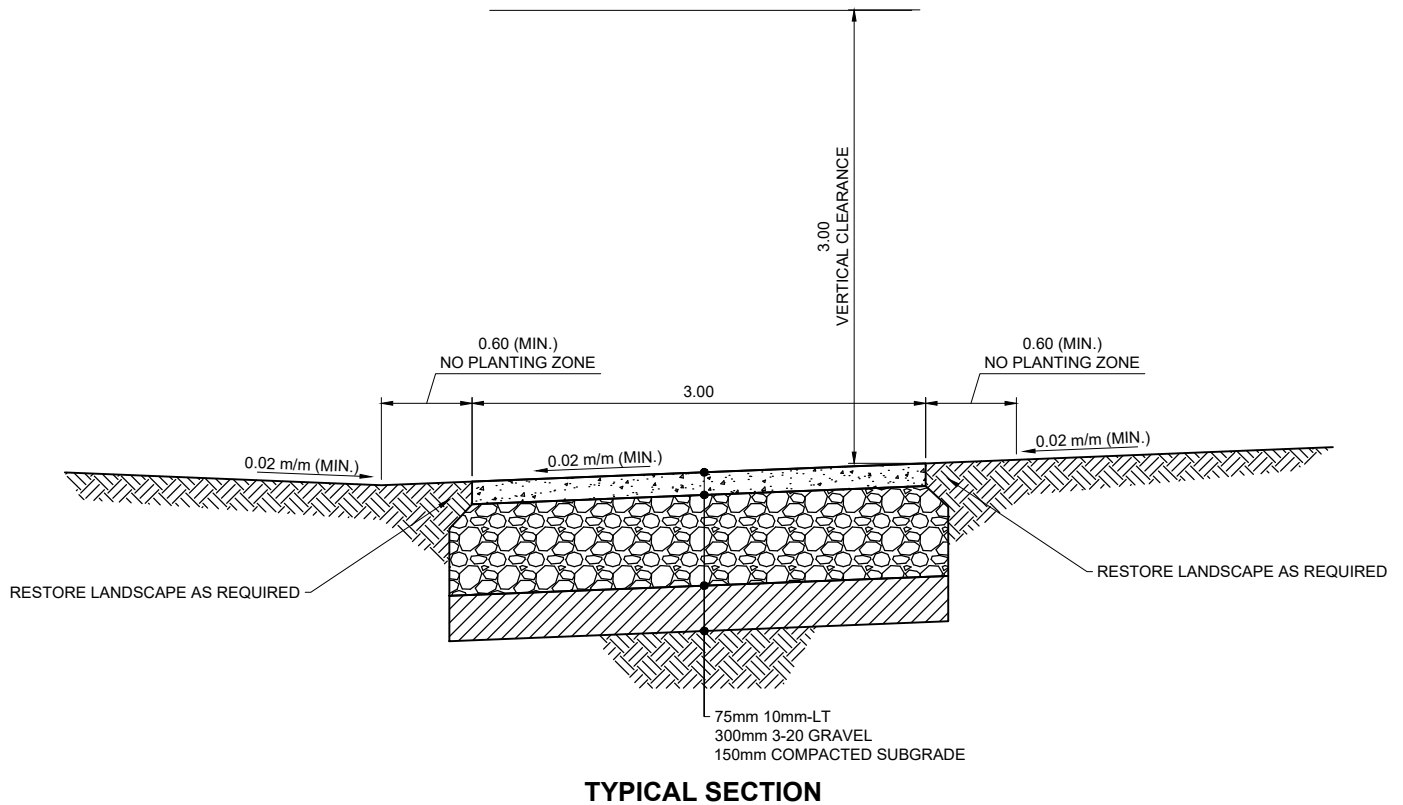

ALTERNATE STRUCTURE:

- 75mm 10mm-LT
- 300mm 3-20 GRAVEL WRAPPED IN NON-WOVEN GEOTEXTILE UP TO EDGES OF EXCAVATION ON NATIVE GROUND

NOTE:

1. FOR 3.00m SHARED PATHWAY WIDTH, 100mm SOLID YELLOW CENTER LINE IS REQUIRED AT THE DISCRETION OF CITY OF EDMONTON

**ALL DIMENSIONS
IN METRES UNLESS
OTHERWISE NOTED**



STANDARD DRAWING

SHARED PATHWAY

DATE APPROVED: **2025**

SCALE: **N.T.S.**

DRAWN BY: **FR**

CHECKED BY: **JN**

APPROVED: 

DRAWING NUMBER: **5160**

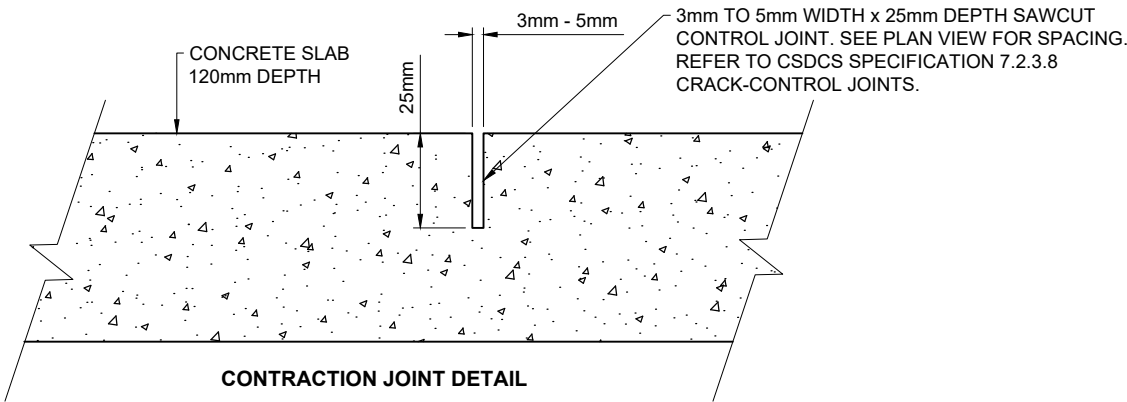
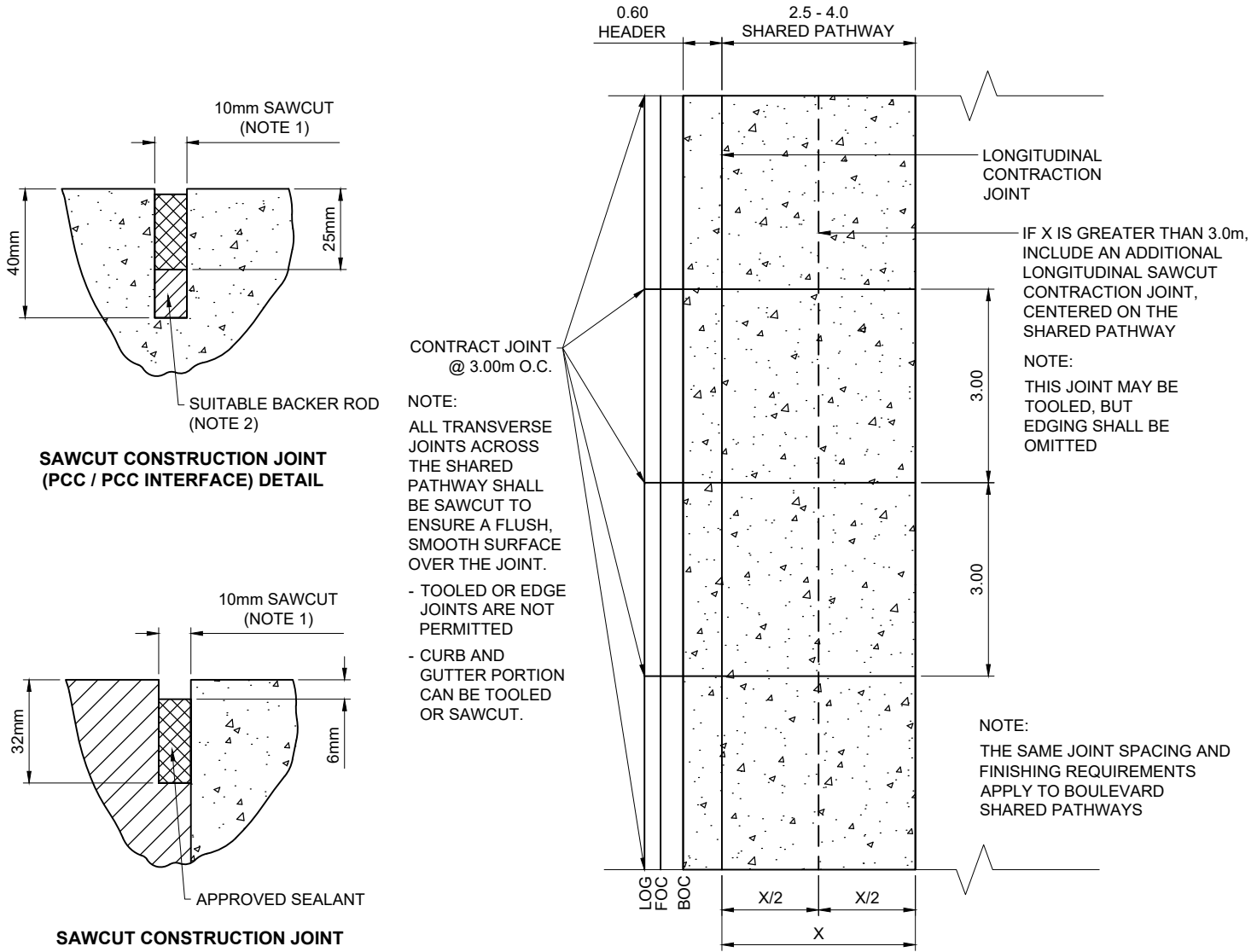

- NOTE:
1. JOINT WIDTHS SHALL BE CONSISTENT THROUGHOUT LENGTH OF JOINT.
 2. BACKER ROD SHALL BE 25% LARGER IN DIAMETRE THAN ACTUAL JOINT WIDTH.

ALL DIMENSIONS IN METRES UNLESS OTHERWISE NOTED

STANDARD DRAWING

SHARED PATHWAY JOINT DETAIL

DATE APPROVED: **2025**

SCALE: **N.T.S.**

DRAWN BY: **FR**

CHECKED BY: **JN**

APPROVED: *[Signature]*

DRAWING NUMBER: **5161**

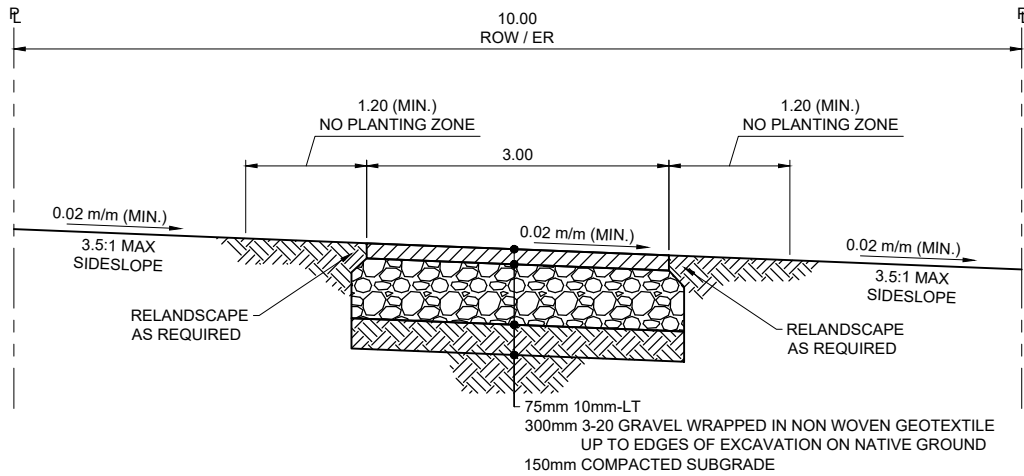

TYPICAL CROSS SECTION

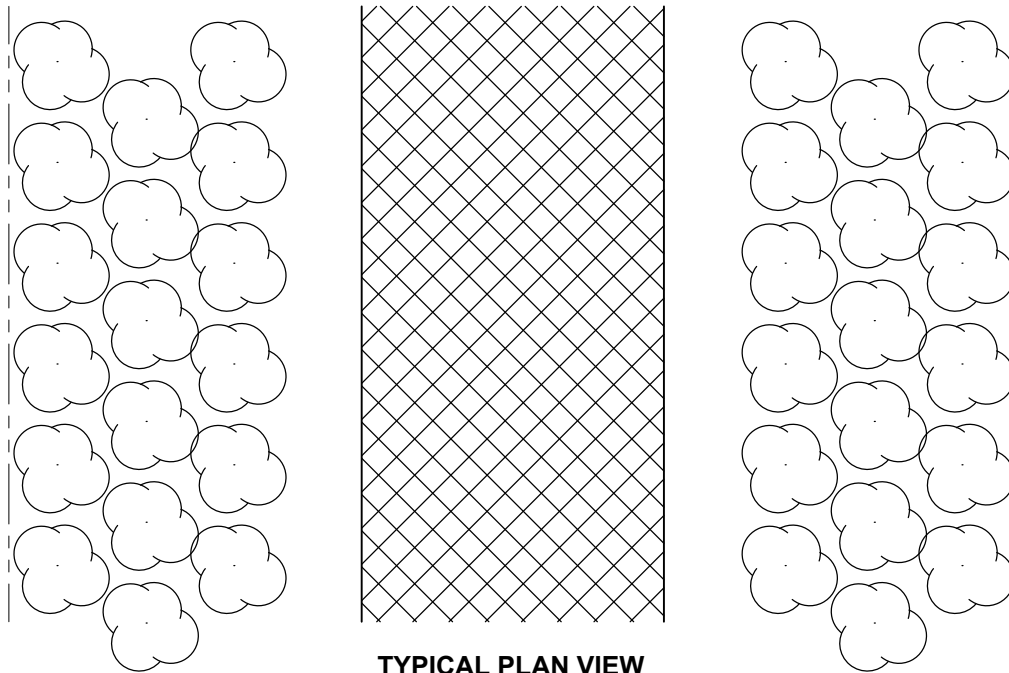

TYPICAL PLAN VIEW

NOTE:

- FOR 3.00m SHARED PATHWAY WIDTH, 100mm SOLID YELLOW CENTER LINE IS REQUIRED AT THE DISCRETION OF CITY OF EDMONTON

**ALL DIMENSIONS
IN METRES UNLESS
OTHERWISE NOTED**

STANDARD DRAWING

TOP OF BANK SHARED PATHWAY

DATE APPROVED: **2025**

SCALE: **N.T.S.**

DRAWN BY: **FR**

CHECKED BY: **JN**

APPROVED:

DRAWING NUMBER: **5165**

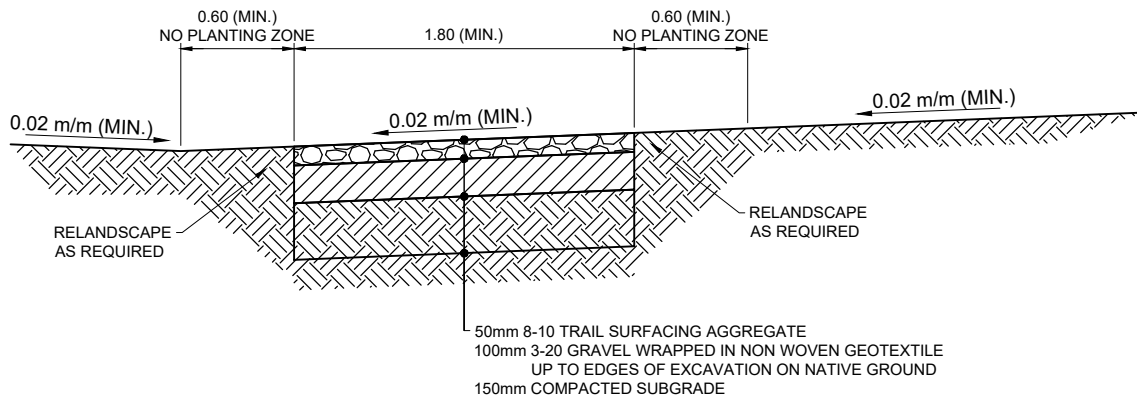

TYPICAL SECTION

ALTERNATE STRUCTURE:

- 50mm 8-10 TRAIL SURFACING AGGREGATE
- 250mm 3-20 GRAVEL WRAPPED IN NON-WOVEN GEOTEXTILE UP TO EDGES OF EXCAVATION ON NATIVE GROUND

**ALL DIMENSIONS
 IN METRES UNLESS
 OTHERWISE NOTED**

GRANULAR WALKWAY



STANDARD DRAWING

DATE APPROVED: **2025**

DRAWN BY: **FR**

APPROVED: *[Signature]*

DRAWING NUMBER: **5170**

SCALE: **N.T.S.**

CHECKED BY: **JN**

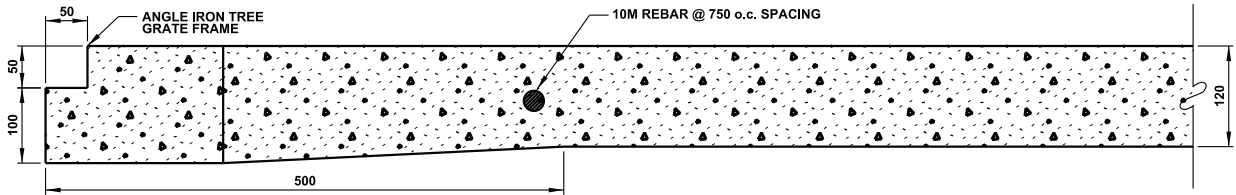
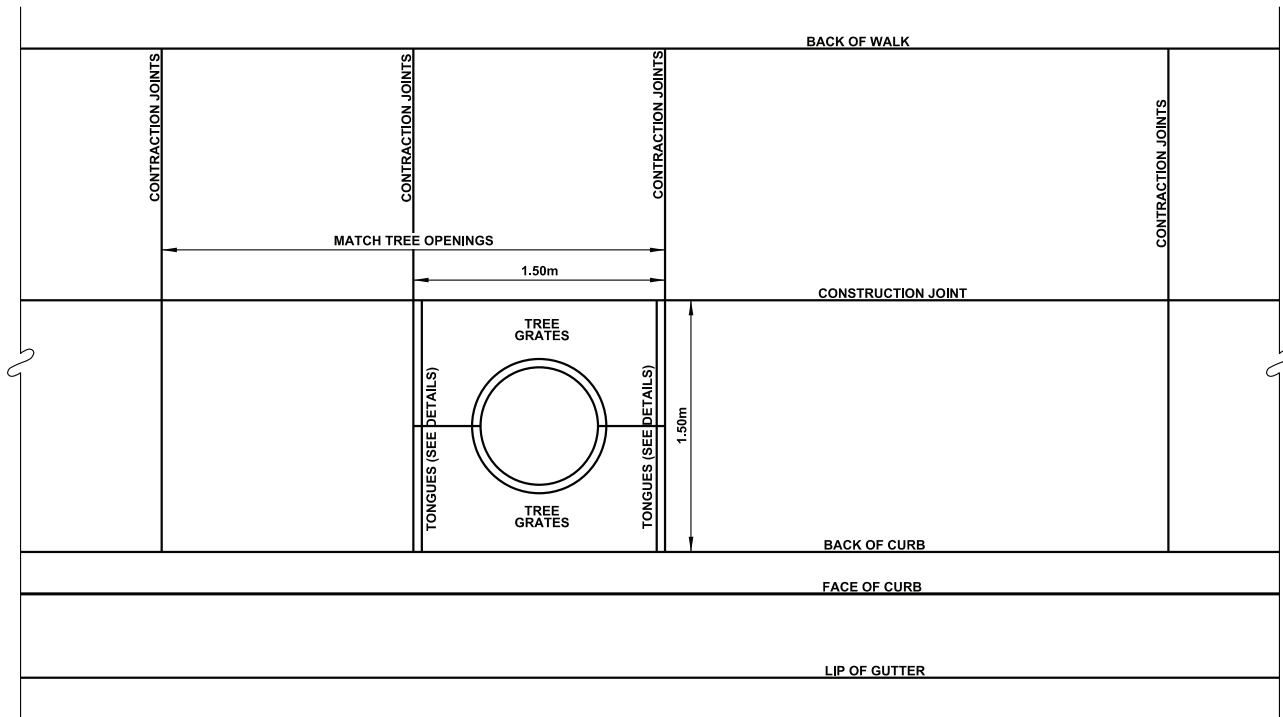

DETAIL OF TONGUE FOR SUPPORT OF TREE GRATES

NOTE:

- 1. GRATE OPENING SHOULD BE SLIGHTLY LESS THAN OPENING.

ALL DIMENSIONS IN MILLIMETRES UNLESS OTHERWISE NOTED

STANDARD DRAWING

SIDEWALK CONSTRUCTION AT TREE OPENING

DATE APPROVED: **2018**
SCALE: **N.T.S.**

DRAWN BY: **KSYC**
CHECKED BY: **JN**

APPROVED: *M.A.R.*

DRAWING NUMBER: **5180**

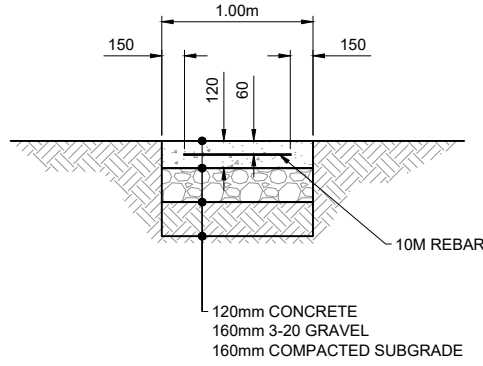

TYPICAL SECTION

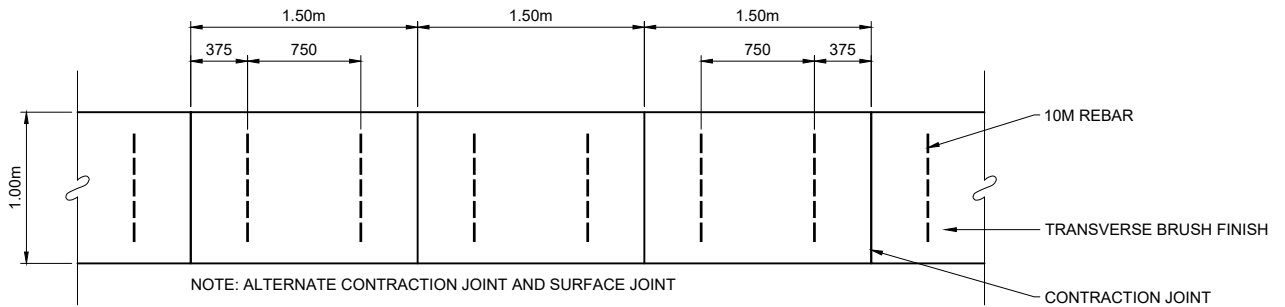

TYPICAL PLAN VIEW

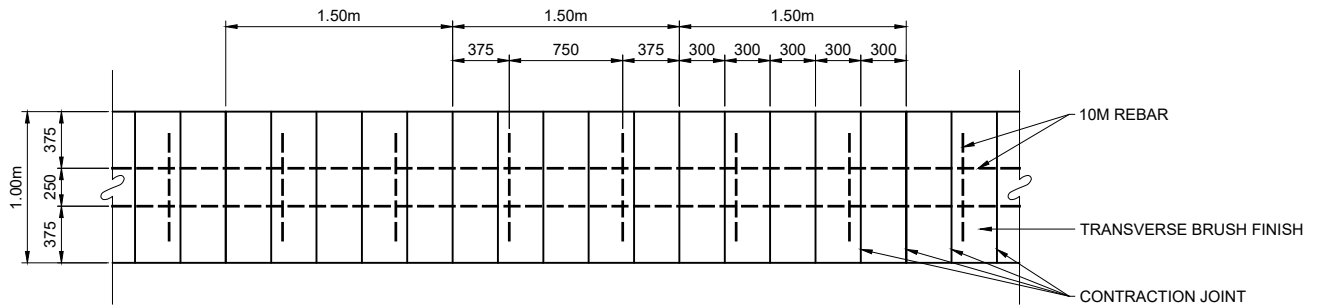

SPECIAL TREATMENT PLAN VIEW

NOTE:

1. ALTERNATE CONTRACTION JOINT AND SURFACE JOINT FOR TYPICAL CONCRETE CONNECTOR WALKWAY CONSTRUCTION.
2. SPECIAL TREATMENT ADJACENT TO EXISTING TREES AS REQUESTED BY ENGINEER.
3. USE ALL CONTRACTION JOINTS WITHIN SPECIAL TREATMENT AREA.
4. LONGITUDINAL REBARS MUST BE CONTINUOUS AND TIED TO THE TRANSVERSE REBARS.

**ALL DIMENSIONS
IN MILLIMETRES UNLESS
OTHERWISE NOTED**

STANDARD DRAWING

1.00m CONNECTOR WALK

DATE APPROVED: **2025**
SCALE: **N.T.S.**

DRAWN BY: **FR**
CHECKED BY: **JN**

APPROVED: *[Signature]*

DRAWING NUMBER: **5185**

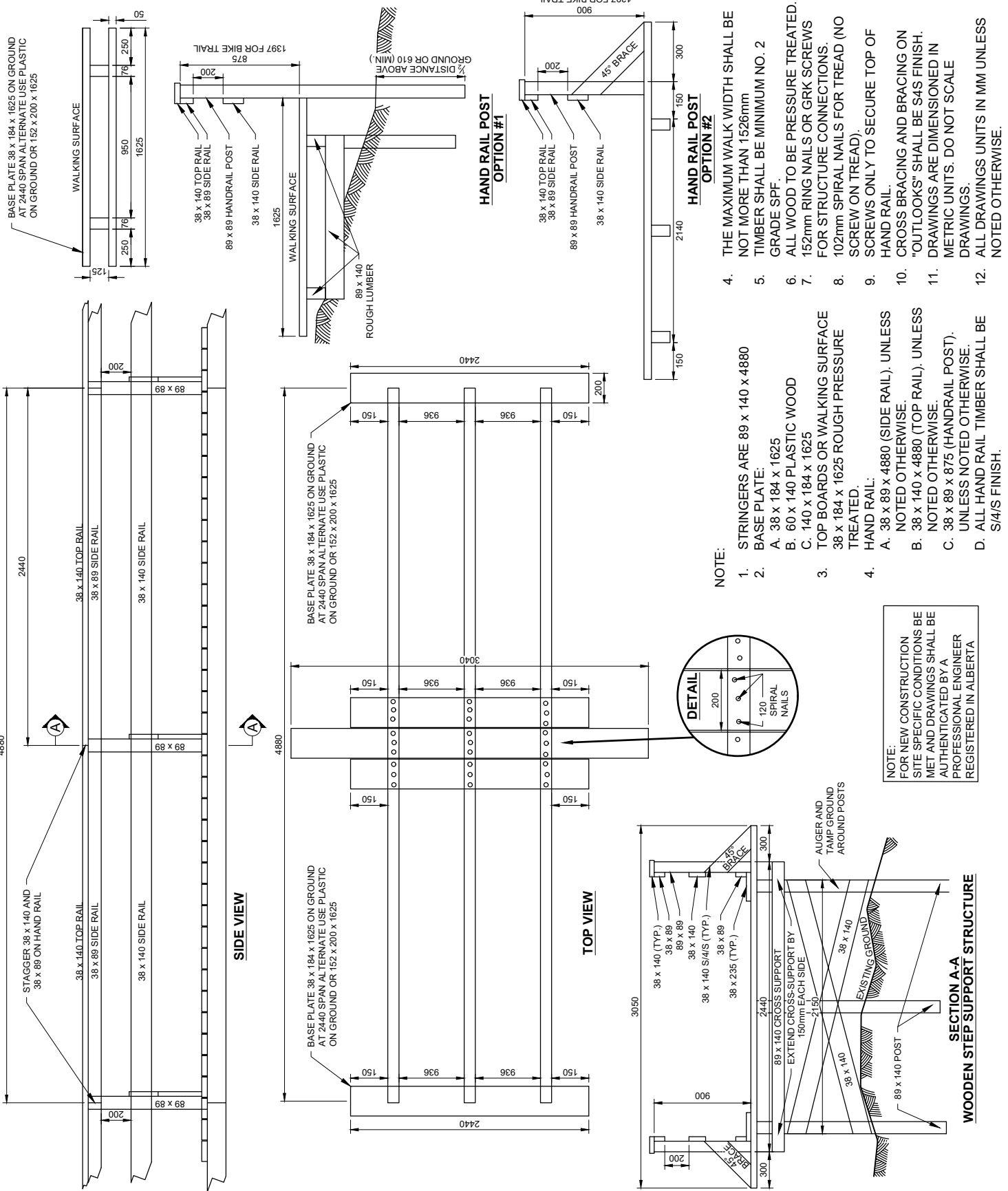

STANDARD DRAWING

WOODEN WALK

DATE APPROVED: **2025**

SCALE: **N.T.S.**

DRAWN BY: **FR**

CHECKED BY: **JN**

APPROVED: *[Signature]*

DRAWING NUMBER: **5200**

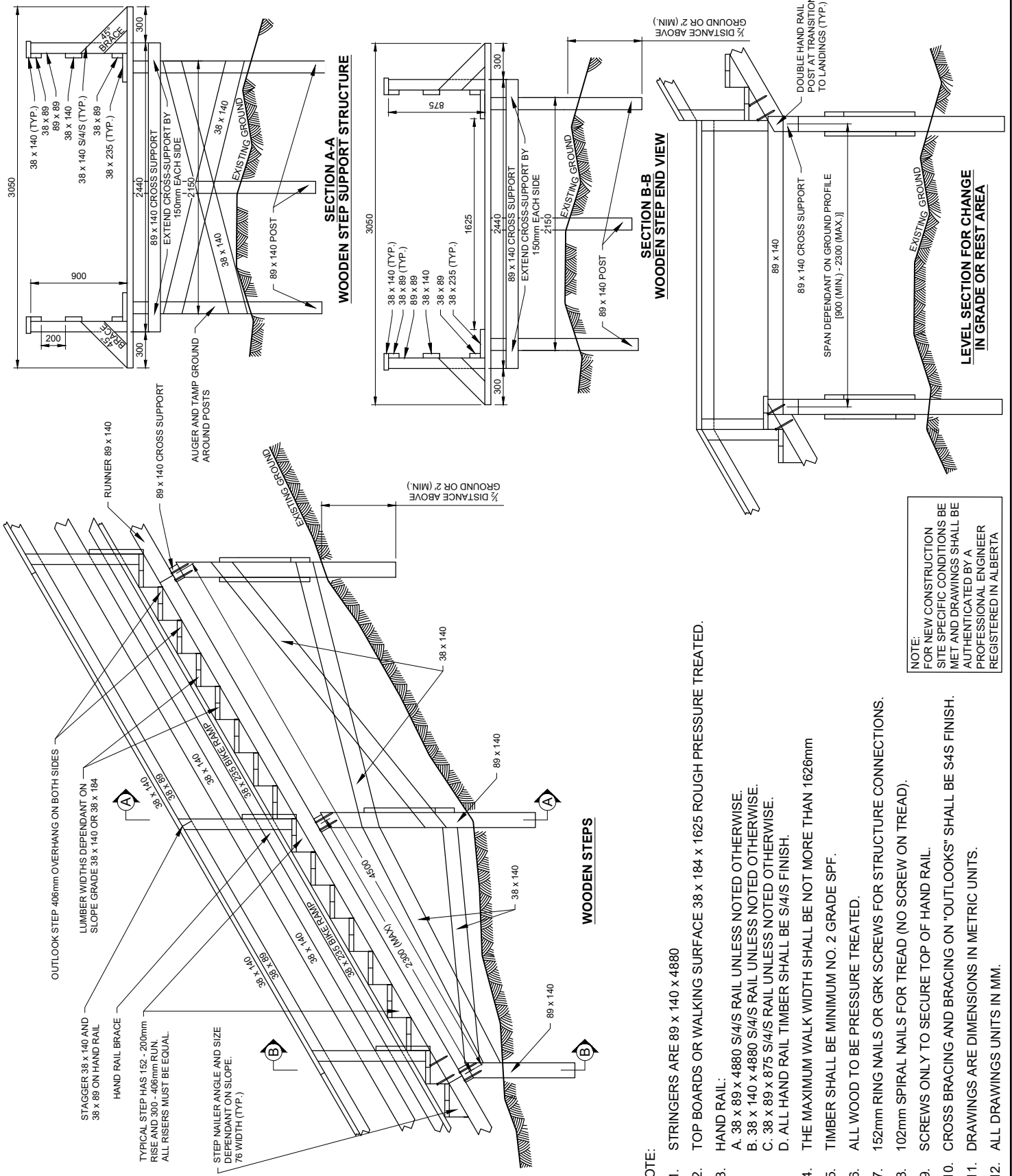

STANDARD DRAWING

WOODEN STAIRS AND SUPPORT STRUCTURE

DATE APPROVED: **2025**
SCALE: **N.T.S.**

DRAWN BY: **FR**
CHECKED BY: **JN**

APPROVED: *[Signature]*

DRAWING NUMBER: **5201**

ALL DIMENSIONS
IN METRES UNLESS
OTHERWISE NOTED

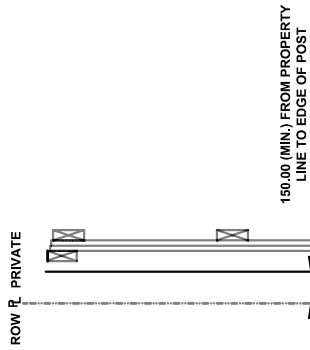
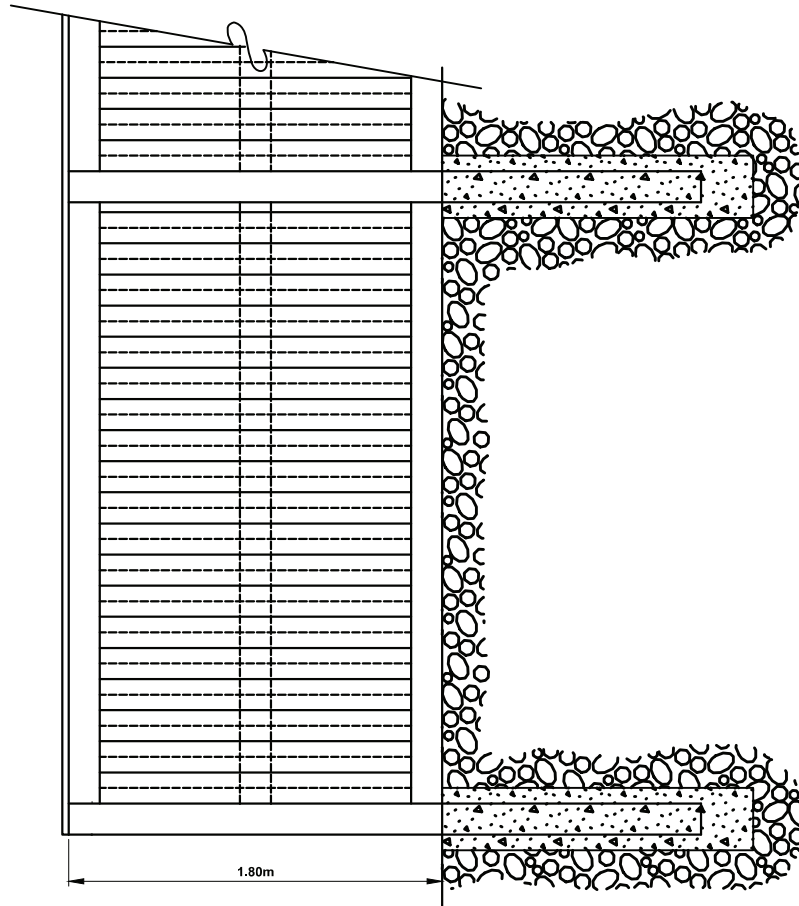
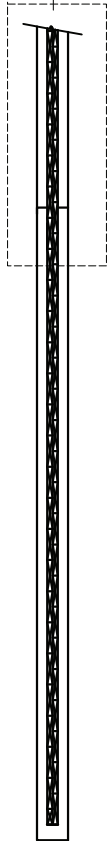
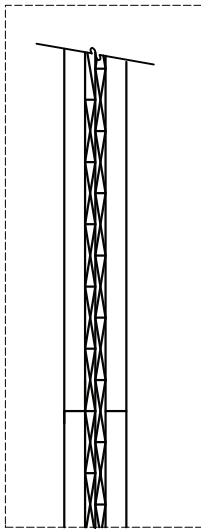

NOTE:

1. FENCE DENSITY TO BE 20kg/m² WITH NO GAPS.
2. NO GAP BETWEEN FINISHED GRADE AND BOTTOM FASER BOARD. MAXIMUM 50mm GAP BETWEEN FINISHED GRADE AND BOTTOM FASER BOARD FOR BACKDRAINING LOT TYPES.

WOODEN NOISE ATTENUATION FENCE



STANDARD DRAWING

DATE APPROVED: **2018**

DRAWN BY: **KSYC**

APPROVED: *M.P.R.*

DRAWING NUMBER: **5205**

SCALE: **N.T.S.**

CHECKED BY: **JN**

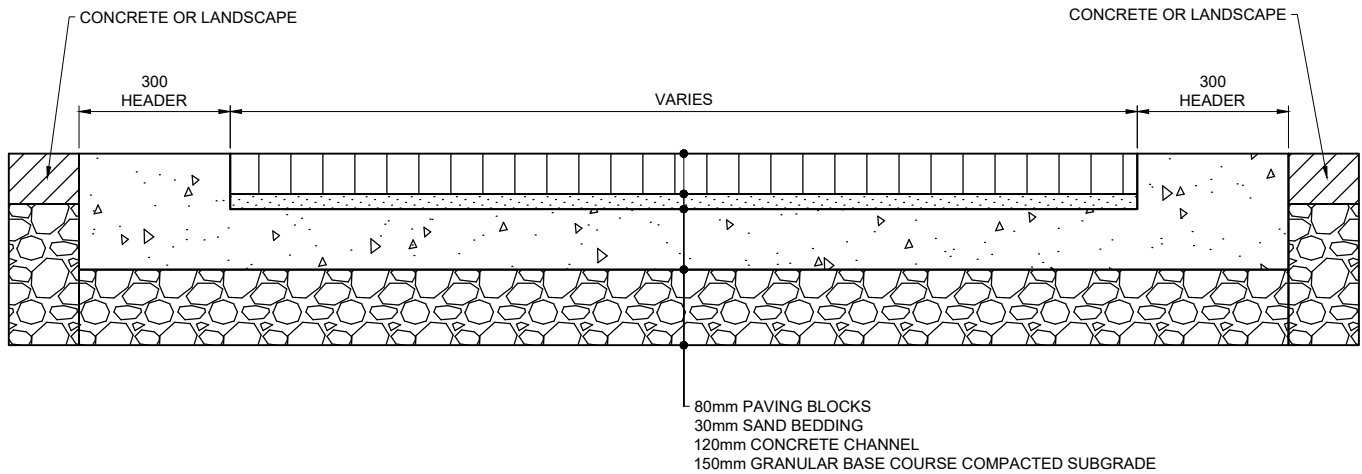

**ALL DIMENSIONS
 IN MILLIMETRES UNLESS
 OTHERWISE NOTED**



STANDARD DRAWING

PAVING BRICK INSTALLATION

DATE APPROVED: **2025**

SCALE: **N.T.S.**

DRAWN BY: **FR**

CHECKED BY: **JN**

APPROVED: 

DRAWING NUMBER: **5215**

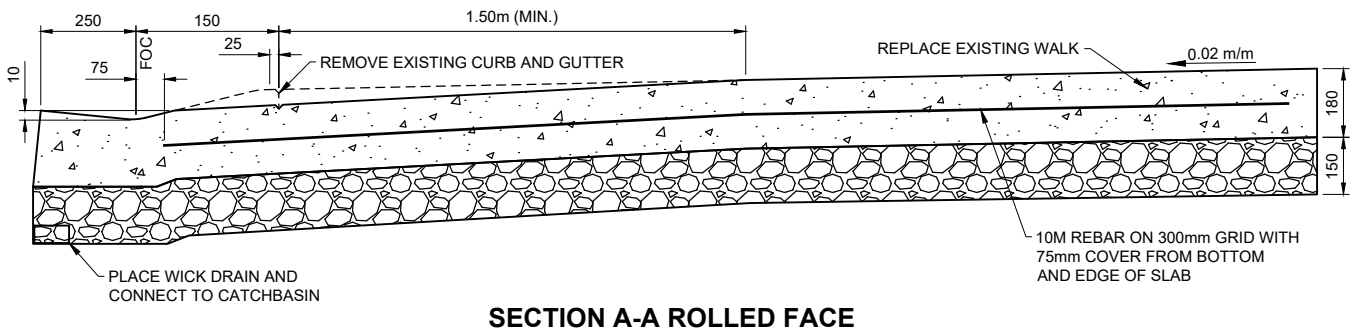
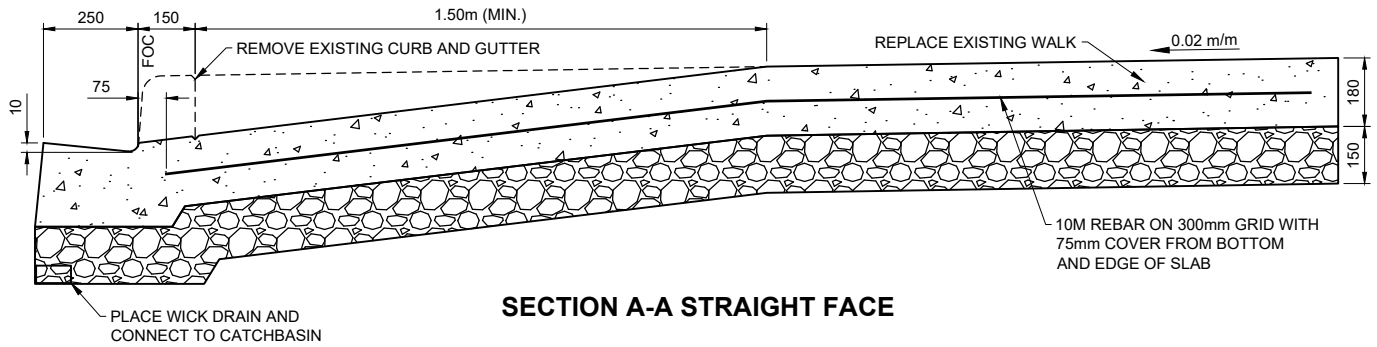
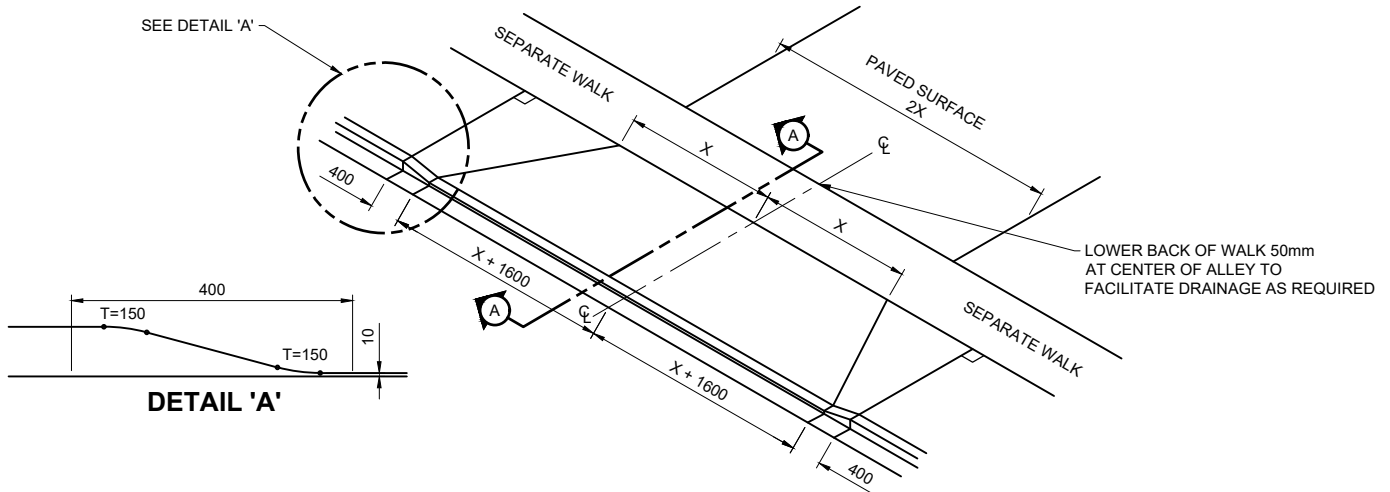

NOTE:

1. MAXIMUM CROSSFALL SLOPE TO BE 8.00% UNLESS OTHERWISE APPROVED BY ENGINEER.
2. CROSSING MUST BE POURED MONOLITHICALLY WITH CURB AND GUTTER.

**ALL DIMENSIONS
IN MILLIMETRES UNLESS
OTHERWISE NOTED**

**ALLEY CROSSING
BOULEVARD WALK AND APRONS**



STANDARD DRAWING

DATE APPROVED: **2025**

DRAWN BY: **FR**

APPROVED: *[Signature]*

DRAWING NUMBER: **5300**

SCALE: **N.T.S.**

CHECKED BY: **JN**

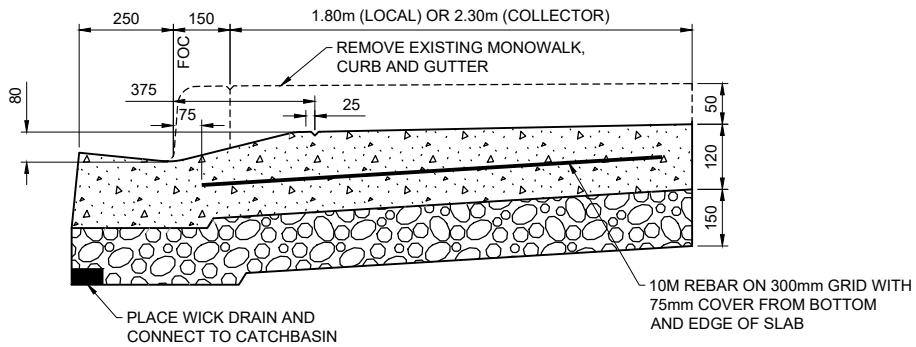
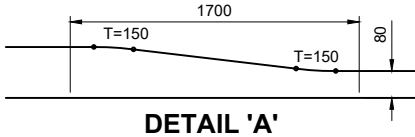
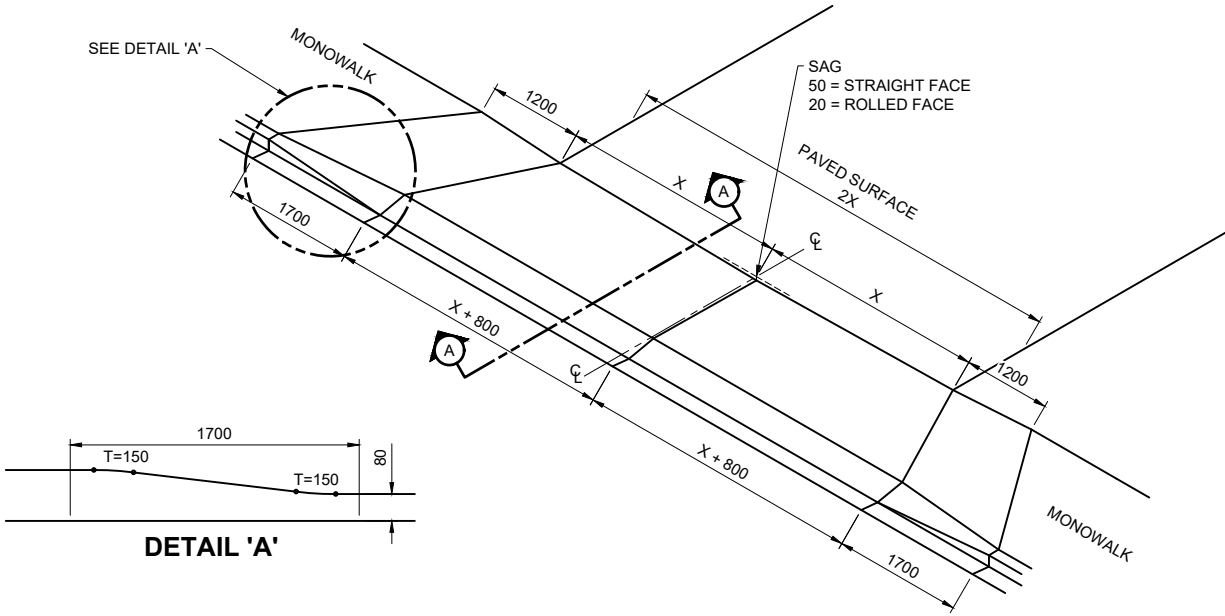

SECTION A-A STRAIGHT FACE

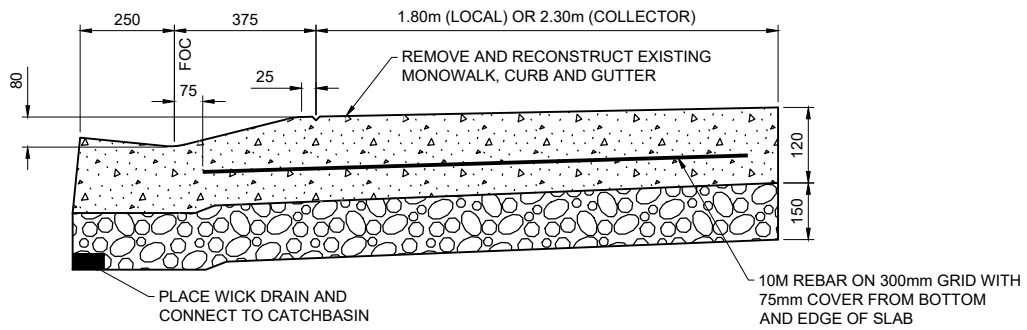

SECTION A-A ROLLED FACE

NOTE:

1. MAXIMUM CROSSFALL SLOPE TO BE 8.00% UNLESS OTHERWISE APPROVED BY ENGINEER.
2. CROSSING MUST BE POURED MONOLITHICALLY WITH CURB AND GUTTER.

**ALL DIMENSIONS
IN MILLIMETRES UNLESS
OTHERWISE NOTED**

STANDARD DRAWING

**ALLEY CROSSING
MONOWALK AND APRONS**

DATE APPROVED: **2025**
SCALE: **N.T.S.**

DRAWN BY: **FR**
CHECKED BY: **JN**

APPROVED: *[Signature]*

DRAWING NUMBER: **5310**

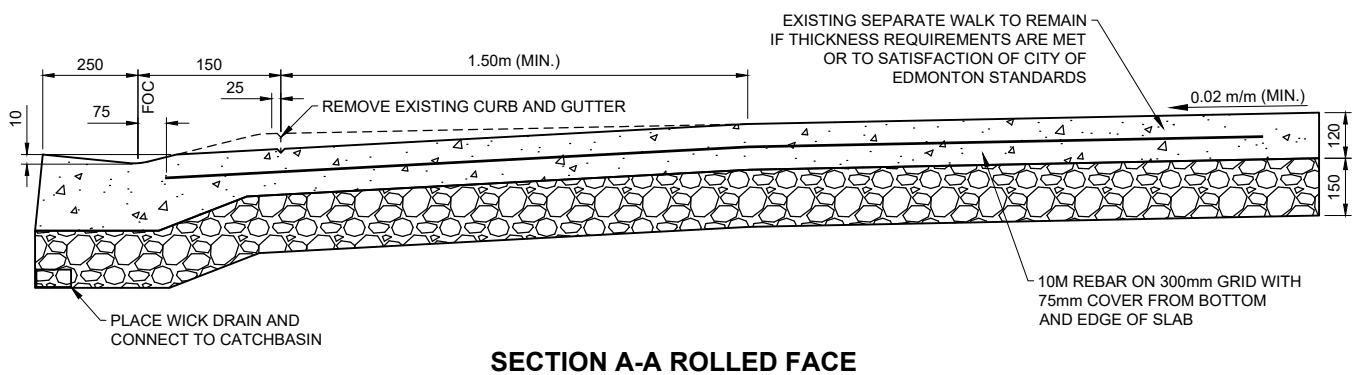
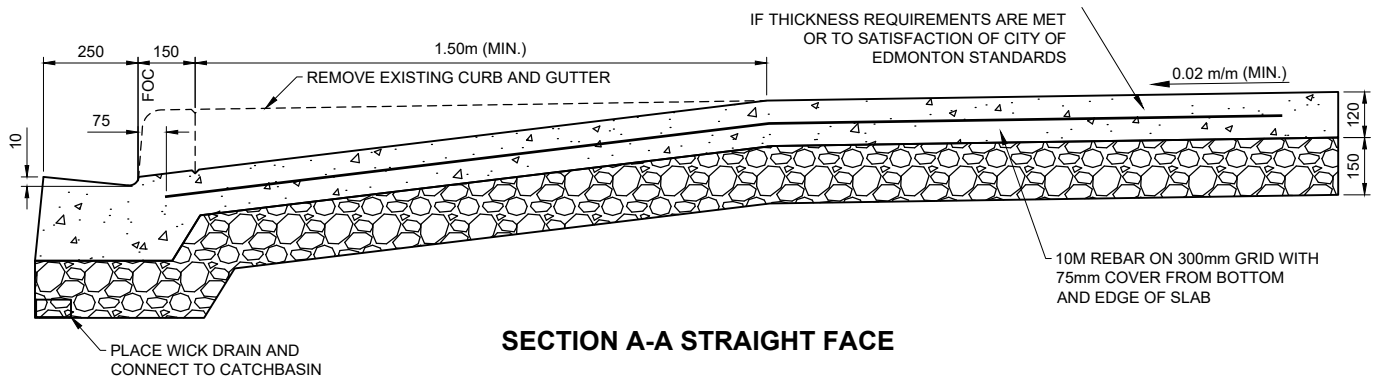
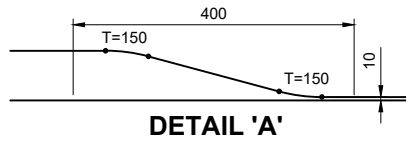
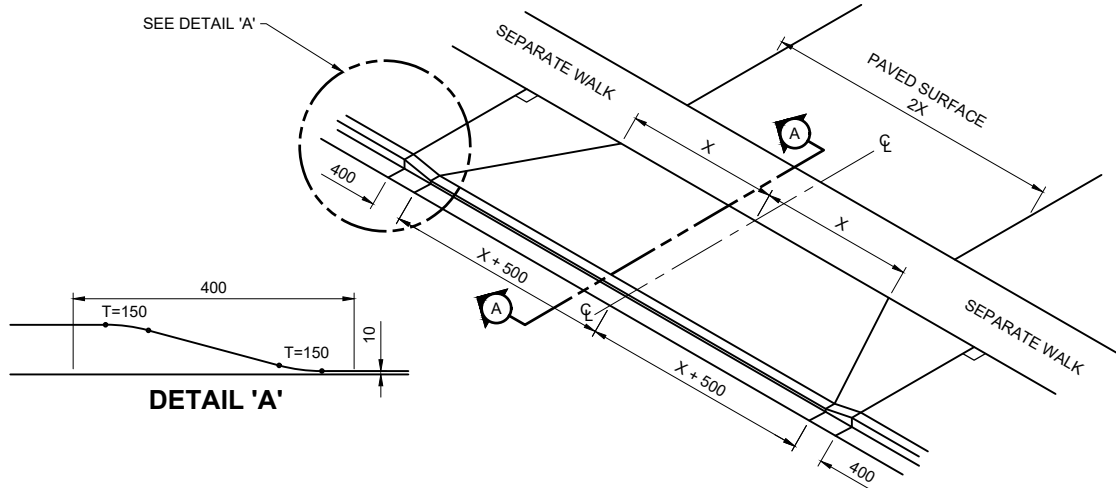

NOTE:

1. MAXIMUM CROSSFALL SLOPE TO BE 8.00% UNLESS OTHERWISE APPROVED BY ENGINEER.
2. CROSSING MUST BE POURED MONOLITHICALLY WITH CURB AND GUTTER.

**ALL DIMENSIONS
IN MILLIMETRES UNLESS
OTHERWISE NOTED**

**PRIVATE CROSSING
SEPARATE WALK AND APRONS**



STANDARD DRAWING

DATE APPROVED: **2025**

DRAWN BY: **FR**

APPROVED:

DRAWING NUMBER: **5320**

SCALE: **N.T.S.**

CHECKED BY: **JN**

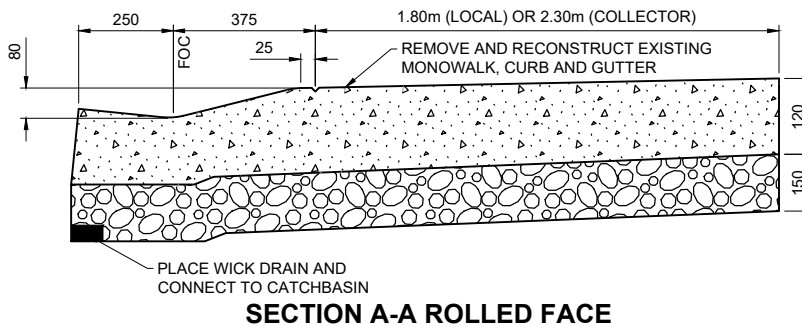
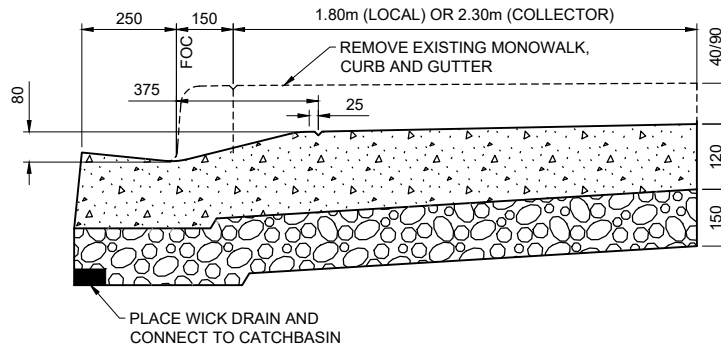
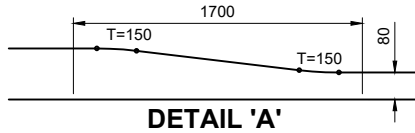
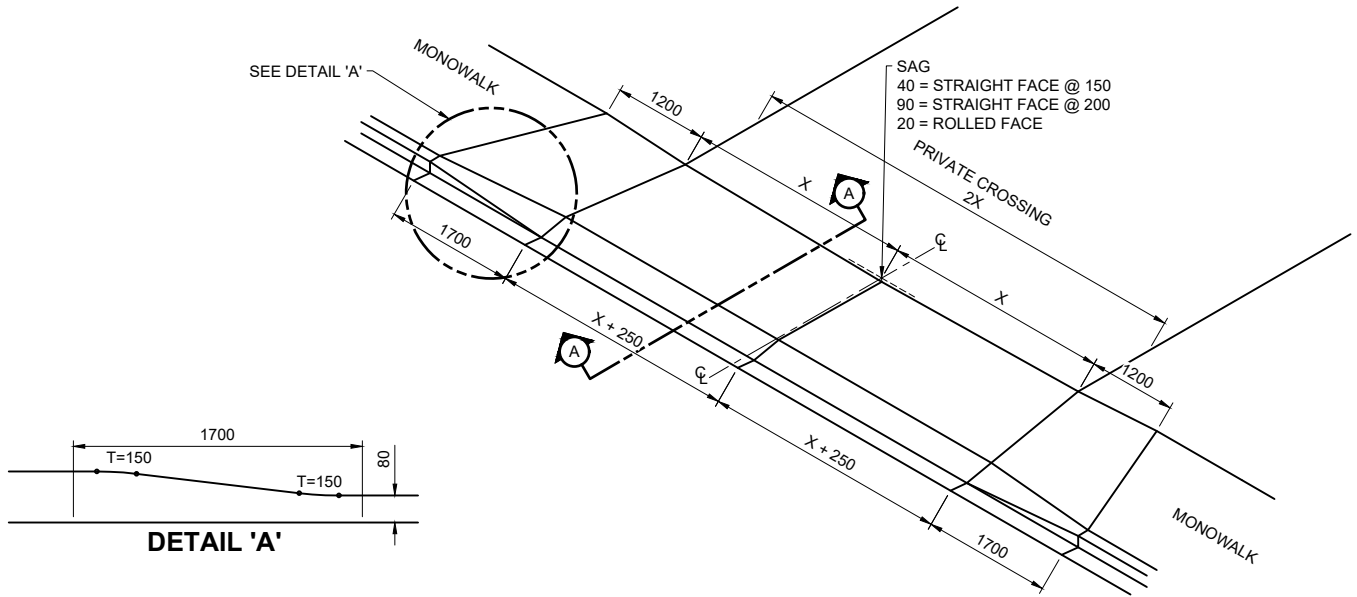

NOTE:

1. MAXIMUM CROSSFALL SLOPE TO BE 8.00% UNLESS OTHERWISE APPROVED BY ENGINEER.
2. CROSSING MUST BE POURED MONOLITHICALLY WITH CURB AND GUTTER.
3. BACK OF CROSSING DROP FOR EXISTING 200mm CURBFACE TO BE 50mm.

**ALL DIMENSIONS
 IN MILLIMETRES UNLESS
 OTHERWISE NOTED**

STANDARD DRAWING

**PRIVATE CROSSING
 MONOWALK AND APRONS**

DATE APPROVED: **2025**

SCALE: **N.T.S.**

DRAWN BY: **FR**

CHECKED BY: **JN**

APPROVED:

DRAWING NUMBER: **5330**

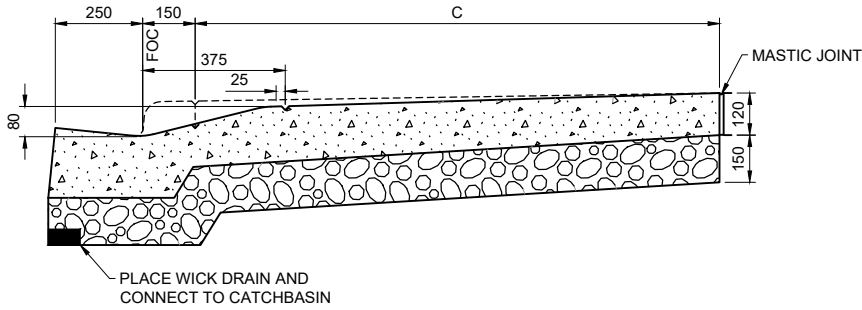
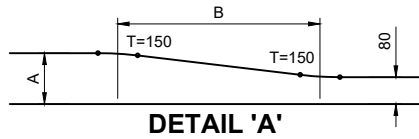
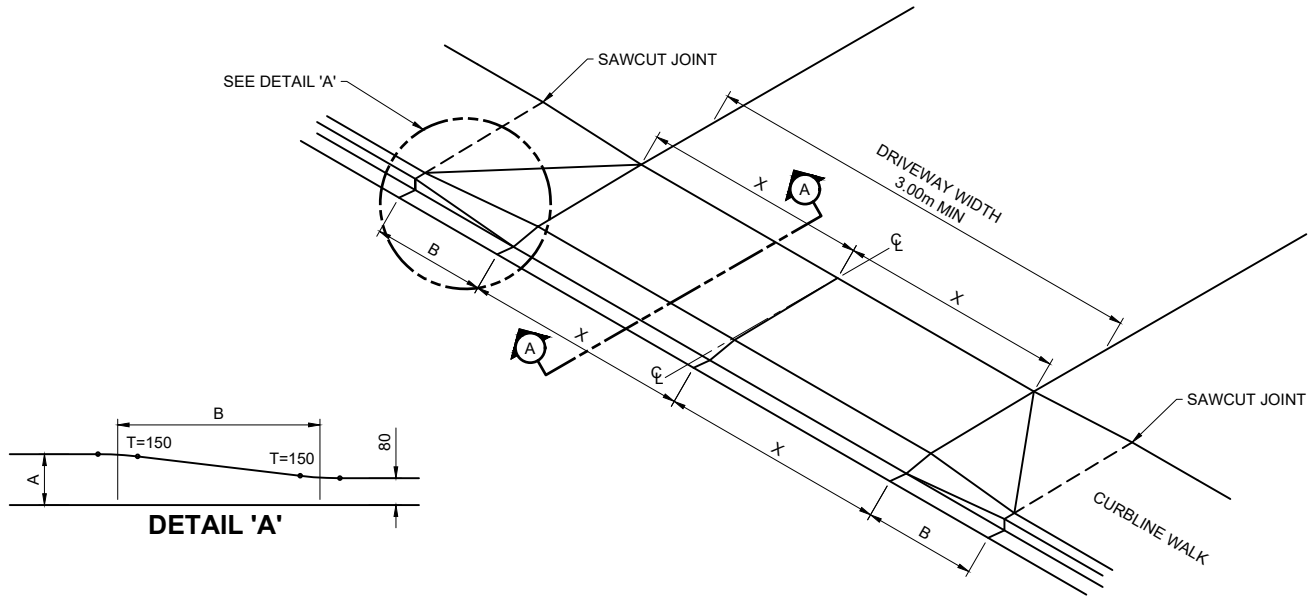

SECTION A-A STRAIGHT FACE

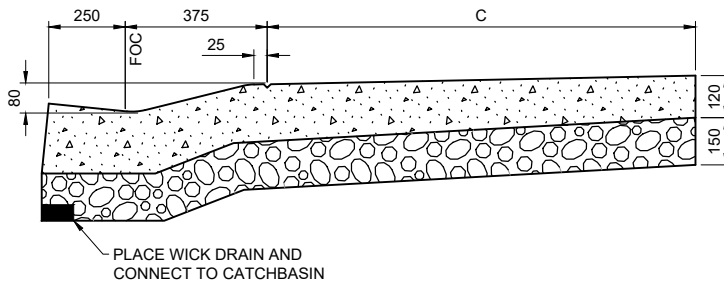

SECTION A-A ROLLED FACE

CURB HEIGHT	125	150	200	215	A
ROLLED UP	1250	1500	2200	2700	B
FOC - BOW	1250	1500	2200	2700	C

NOTE:

1. MAXIMUM CROSSFALL SLOPE TO BE 8.00% UNLESS OTHERWISE APPROVED BY ENGINEER.
2. CROSSING MUST BE POURED MONOLITHICALLY WITH CURB AND GUTTER.

**ALL DIMENSIONS
IN MILLIMETRES UNLESS
OTHERWISE NOTED**

STANDARD DRAWING

**PRIVATE CROSSING
MONOWALK (RETROFIT)**

DATE APPROVED: **2025**
SCALE: **N.T.S.**

DRAWN BY: **FR**
CHECKED BY: **JN**

APPROVED: *[Signature]*

DRAWING NUMBER: **5340**

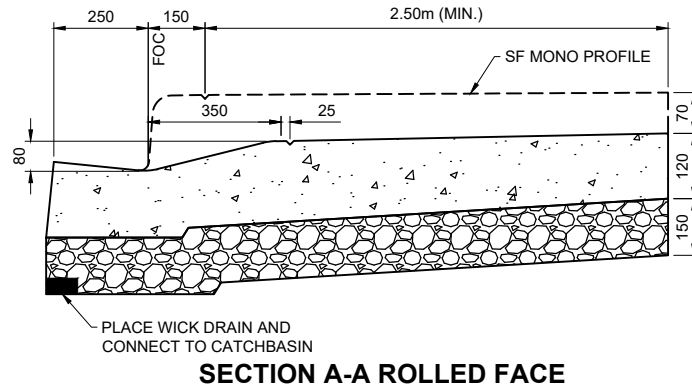
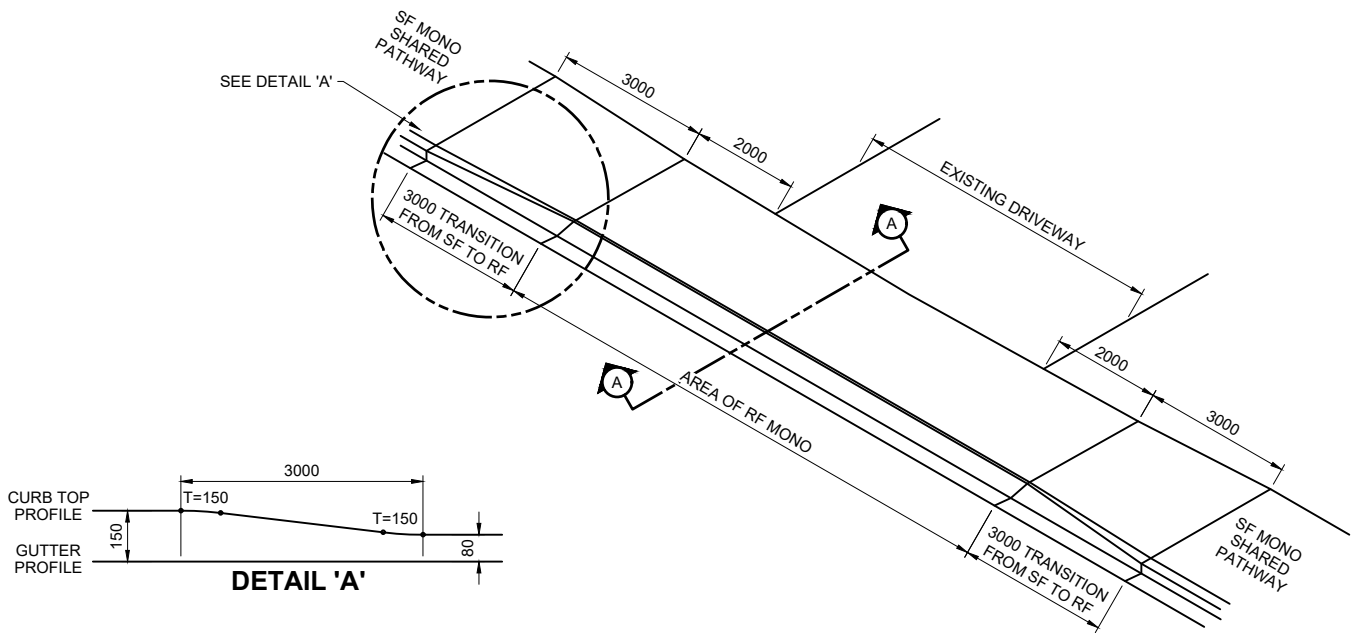

NOTE:

1. MAXIMUM CROSSFALL SLOPE TO BE 2.00% UNLESS OTHERWISE APPROVED BY ENGINEER.
2. CROSSING MUST BE POURED MONOLITHICALLY WITH CURB AND GUTTER.
3. MAINTAIN LIP OF GUTTER AND BACK OF WALK ALIGNMENTS.
4. SHARED PATHWAY WIDTH THROUGH AREA OF RF MONOWALK WILL BE 0.225m NARROWER THAN FOR THE SF MONO.
5. SHARED PATHWAY WIDTH TO BE MIN. 2.5m.
6. FOR STREETS WITH MULTIPLE DRIVEWAYS, RF MONO MAY BE USED FOR THE ENTIRE BLOCK OR ACROSS TWO OR MORE DRIVEWAYS, DEPENDING ON BETWEEN DRIVEWAYS SPACING AS DETERMINED BY THE CITY.

**ALL DIMENSIONS
IN MILLIMETRES UNLESS
OTHERWISE NOTED**

STANDARD DRAWING

**PRIVATE CROSSING
MONOLITHIC SHARED PATHWAY (RETROFIT)**

DATE APPROVED: **2025**

SCALE: **N.T.S.**

DRAWN BY: **FR**

CHECKED BY: **JN**

APPROVED:

DRAWING NUMBER: **5341**

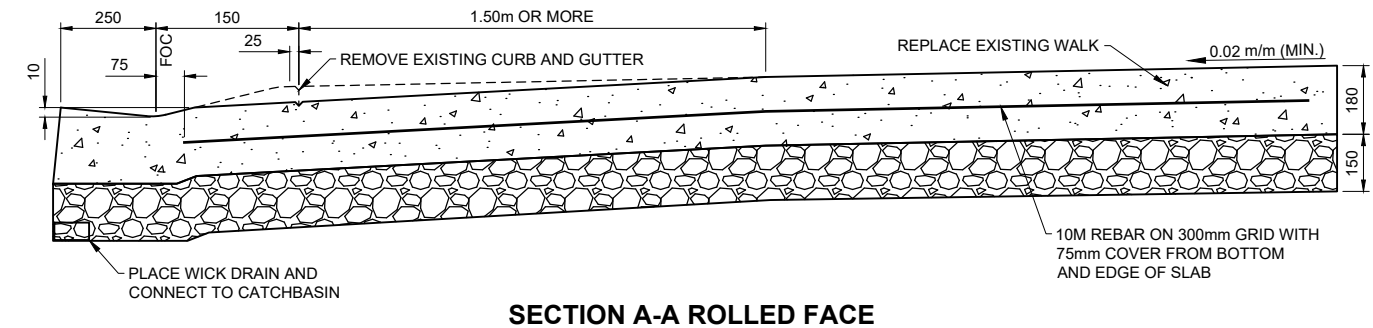
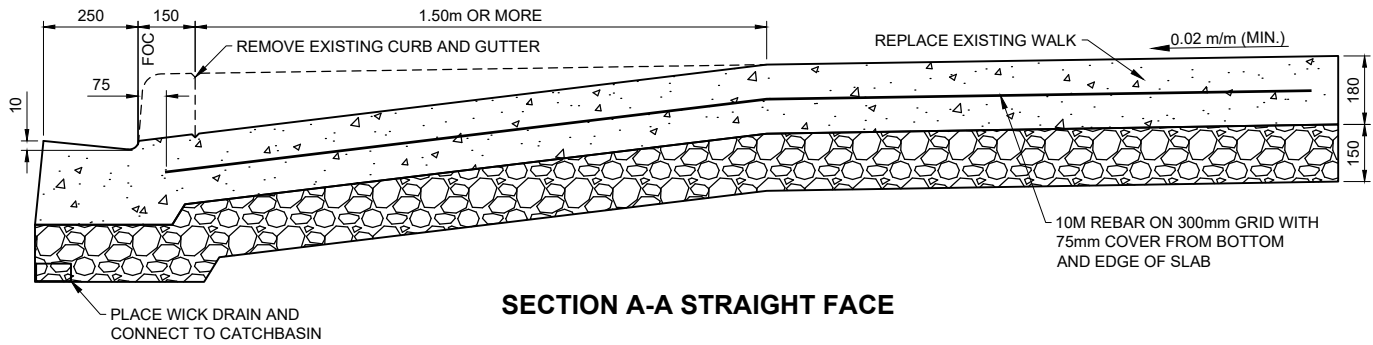
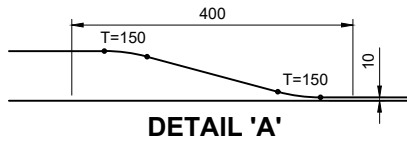
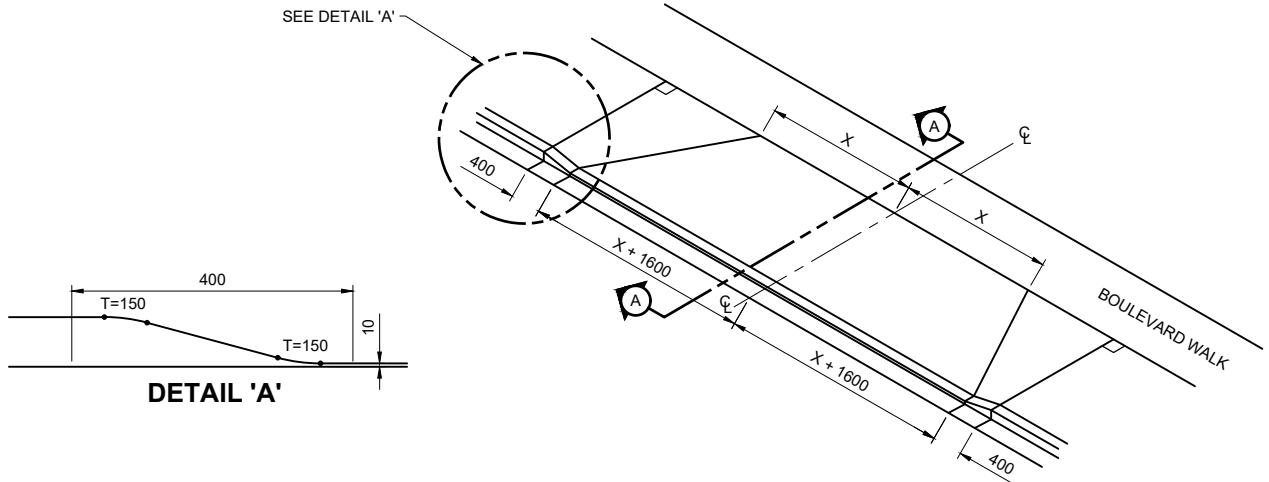

- NOTE:
1. MAXIMUM CROSSFALL SLOPE TO BE 8.00% UNLESS OTHERWISE APPROVED BY ENGINEER.
 2. CROSSING MUST BE POURED MONOLITHICALLY WITH CURB AND GUTTER.

**ALL DIMENSIONS
IN MILLIMETRES UNLESS
OTHERWISE NOTED**

**COMMERCIAL CROSSING
BOULEVARD WALK AND APRONS
(BOULEVARD > 1.50m)**



STANDARD DRAWING

DATE APPROVED: **2025**

DRAWN BY: **FR**

APPROVED:

DRAWING NUMBER: **5400**

SCALE: **N.T.S.**

CHECKED BY: **JN**

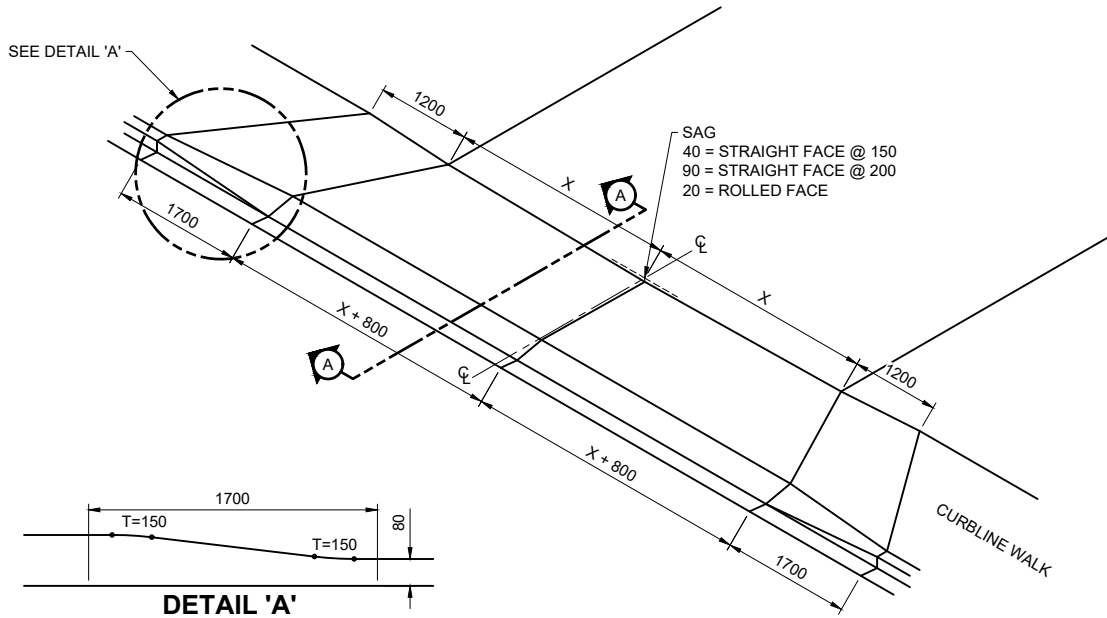

DETAIL 'A'

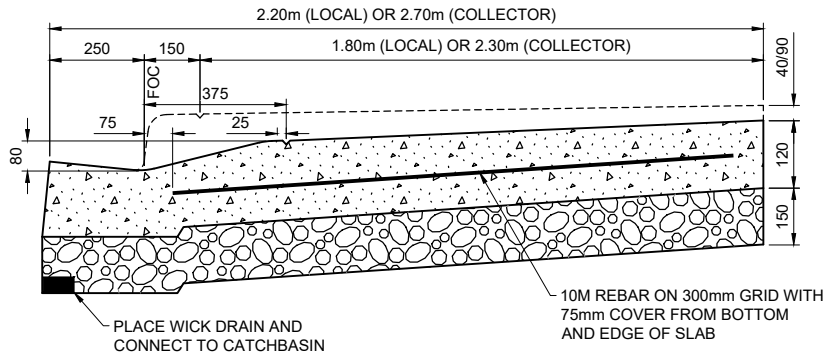

SECTION A-A STRAIGHT FACE

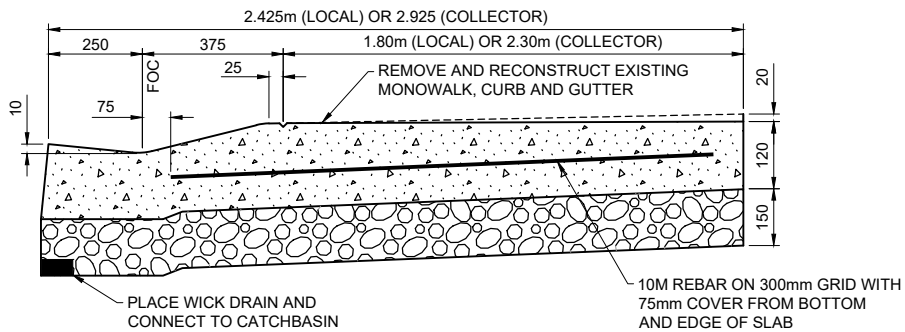

SECTION A-A ROLLED FACE

NOTE:

1. MAXIMUM CROSSFALL SLOPE TO BE 8.00% UNLESS OTHERWISE APPROVED BY ENGINEER.
2. CROSSING MUST BE POURED MONOLITHICALLY WITH CURB AND GUTTER.

**ALL DIMENSIONS
IN MILLIMETRES UNLESS
OTHERWISE NOTED**

STANDARD DRAWING

**COMMERCIAL CROSSING MONOWALK AND BOULEVARD WALK
(BOULEVARD < 1.50m)**

DATE APPROVED: 2025	DRAWN BY: FR	APPROVED: 	DRAWING NUMBER: 5410
SCALE: N.T.S.	CHECKED BY: JN		

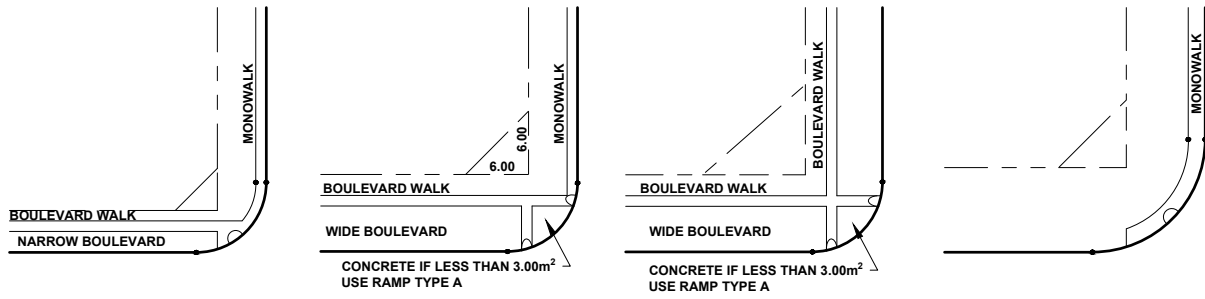

RAMP TYPE A

RAMP TYPE B

RAMP TYPE B

RAMP TYPE A

CORNER LAYOUT

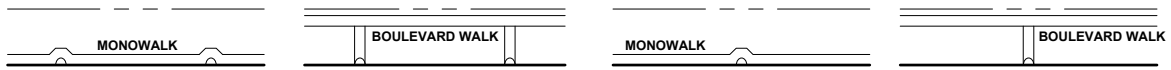

RAMP TYPE C

RAMP TYPE D

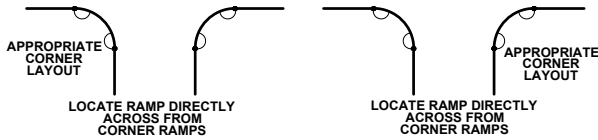

RAMP TYPE C

RAMP TYPE D

TANGENT LAYOUT

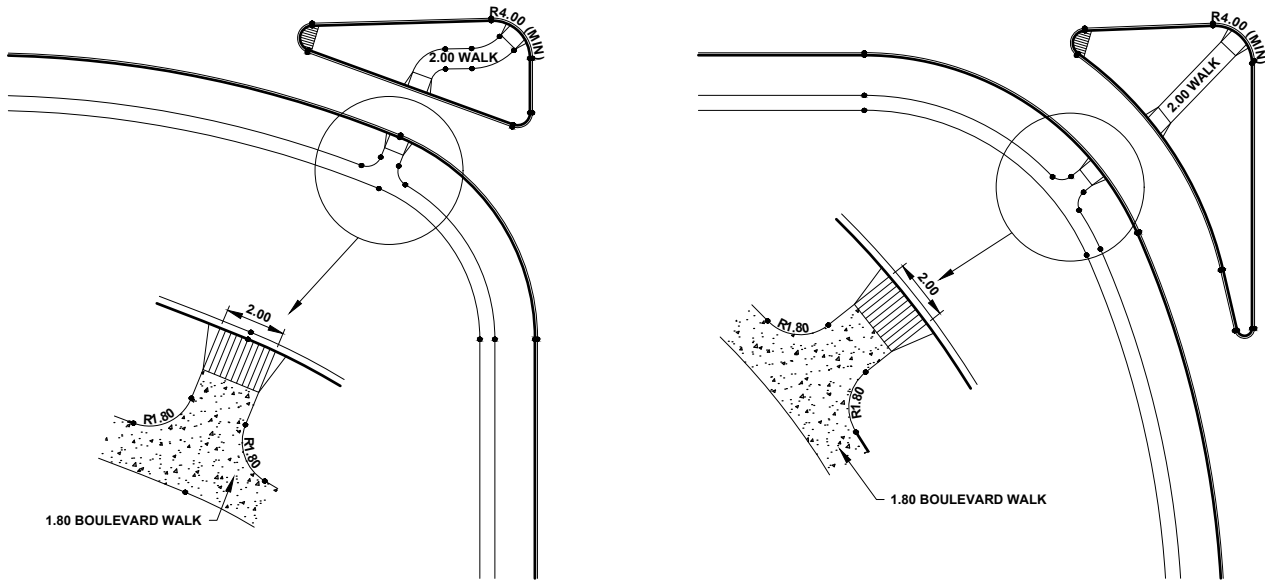

RAMP TYPE D
HIGH ENTRY ANGLE RIGHT TURN LAYOUT

RAMP TYPE D
LOW EXIT ANGLE RIGHT TURN LAYOUT

NOTE:

1. SEE DRAWING #5510 FOR RAMP TYPES
2. ARTERIAL - ARTERIAL INTERSECTION:
 - 1.80m BOULEVARD WALK BECOMES 3.00m SHARED PATHWAY
 - 2.00m CURB RAMP PAN BECOMES 3.00m CURB RAMP PAN

**ALL DIMENSIONS
IN METRES UNLESS
OTHERWISE NOTED**

STANDARD DRAWING

CURB RAMP LOCATIONS

DATE APPROVED: 2025	DRAWN BY: FR	APPROVED: 	DRAWING NUMBER: 5500
SCALE: N.T.S.	CHECKED BY: JN		

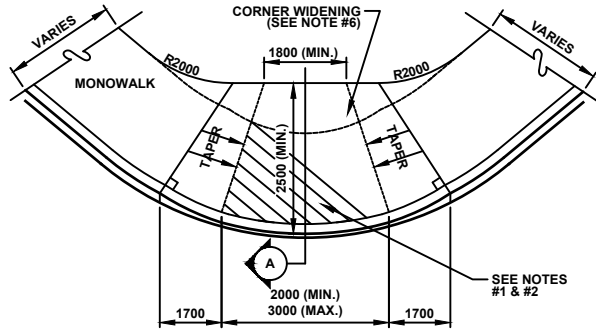

TYPE A1 (ONE DIRECTION)

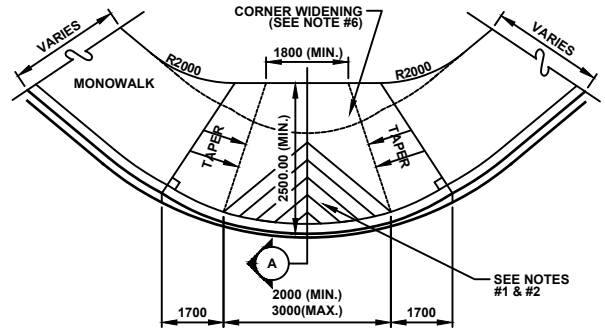

TYPE A2 (TWO DIRECTIONS)

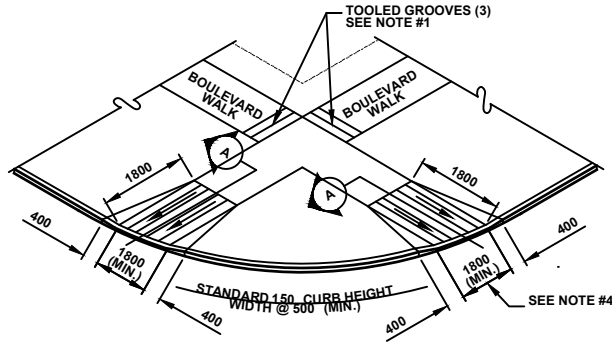

TYPE B

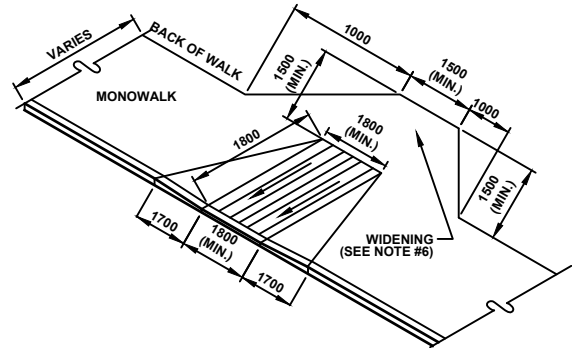

TYPE C

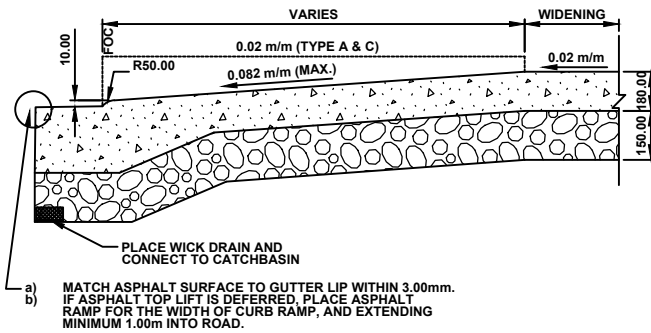

TYPICAL CROSS SECTION A-A

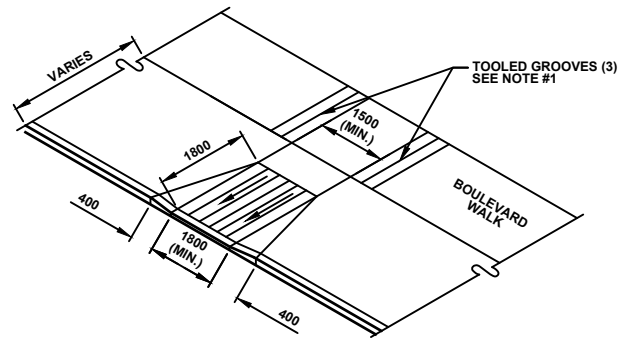

TYPE D

NOTE:

1. TOOLED GROOVES 5mm WIDE x 10mm DEEP, BROOM FINISHED. GROOVES SPACING 150mm o.c. ADJACENT TO CURB.
2. GROOVES TO BE IN DIRECTION OF TRAVEL.
3. WHEN REQUIRED, TRANSITION FROM STRAIGHT FACE CURB TO ROLLED FACE CURB AT CURB RAMP.
4. CURBS AND RAMPS TO BE POURED MONOLITHICALLY.
5. WIDTH OF RAMP MUST EQUAL WIDTH OF WALK (1.80m MIN., 3.00m MAX.) EXCEPT "TYPE A".
6. PROVIDE 1.00m WIDENING (AT 2.00% MIN. X-FALL) FROM BACK OF CURB RAMP (TYPES A & C) WHERE ROAD RIGHT OF WAY ALLOWS.
7. 1500mm x 1500mm LEVEL SURFACE SHALL BE MAINTAINED ON THE SIDEWALK BEHIND CURB RAMPS.
8. FOR BOULEVARD WALK TO CURBLINE WALK, REFER TO DRAWING #5500 FOR CURB RAMP LOCATIONS AND TYPES.

**ALL DIMENSIONS
IN MILLIMETRES UNLESS
OTHERWISE NOTED**

STANDARD DRAWING

CURB RAMP

DATE APPROVED: 2025	DRAWN BY: FR	APPROVED: 	DRAWING NUMBER: 5510
SCALE: N.T.S.	CHECKED BY: JN		

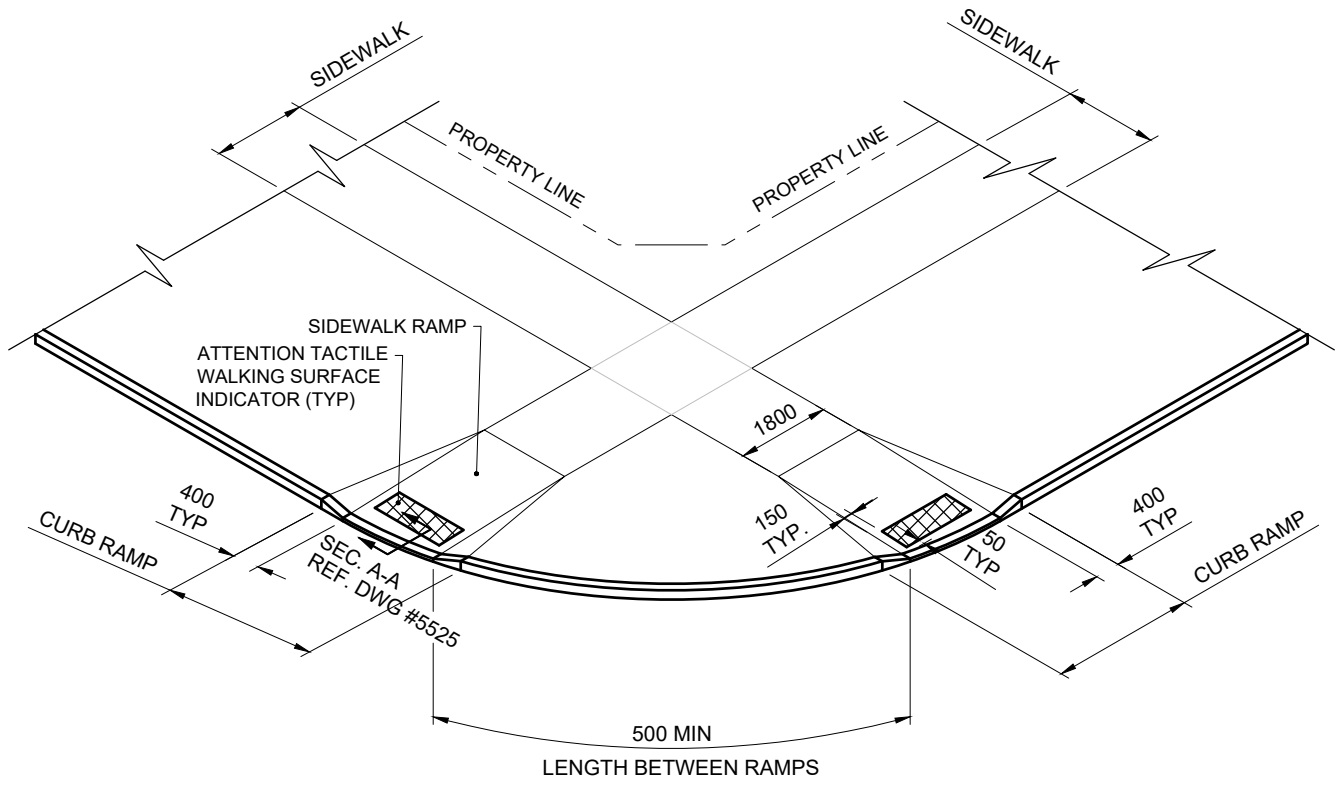

STANDARD LAYOUT

**ALL DIMENSIONS
IN MILLIMETRES UNLESS
OTHERWISE NOTED**



STANDARD DRAWING

**TACTILE WALKING SURFACE INDICATOR (TWSI)
LAYOUT FOR SEPARATE WALK**

DATE APPROVED: **2025**

DRAWN BY: **FR**

APPROVED: *[Signature]*

DRAWING NUMBER: **5520**

SCALE: **N.T.S.**

CHECKED BY: **JN**

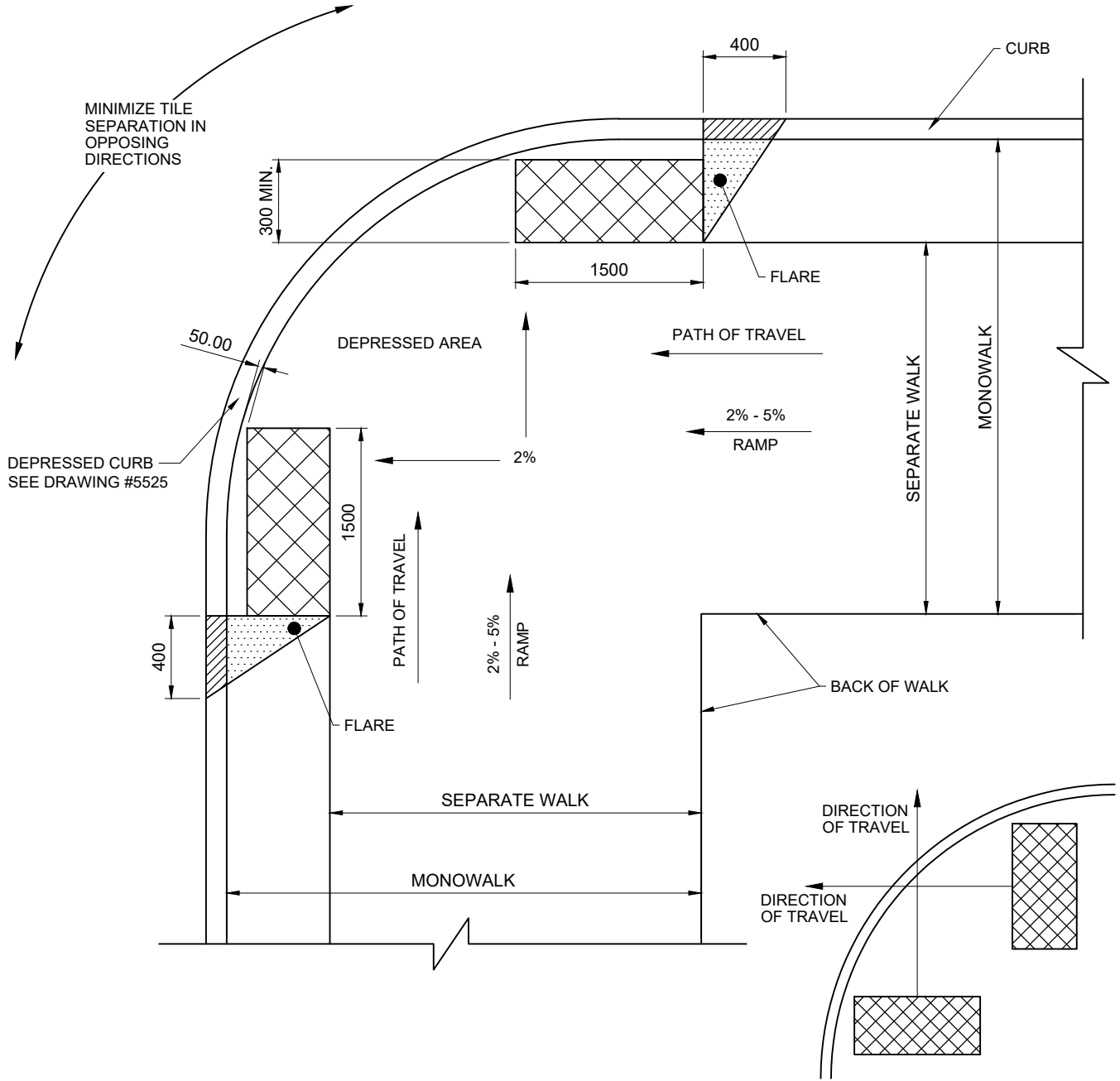

NOT ALLOWED

SEE NOTE 1

**ALL DIMENSIONS
IN MILLIMETRES UNLESS
OTHERWISE NOTED**

NOTE:

- 1. ON THE STREETSIDE OF ATTENTION TACTILE WALKING SURFACE INDICATOR (TYP), CROSS PATHS OF TRAVEL ARE NOT ALLOWED

STANDARD DRAWING

**TACTILE WALKING SURFACE INDICATOR (TWSI)
LAYOUT FOR WALK**

DATE APPROVED: **2025**
SCALE: **N.T.S.**

DRAWN BY: **FR**
CHECKED BY: **JN**

APPROVED: *[Signature]*

DRAWING NUMBER: **5521**

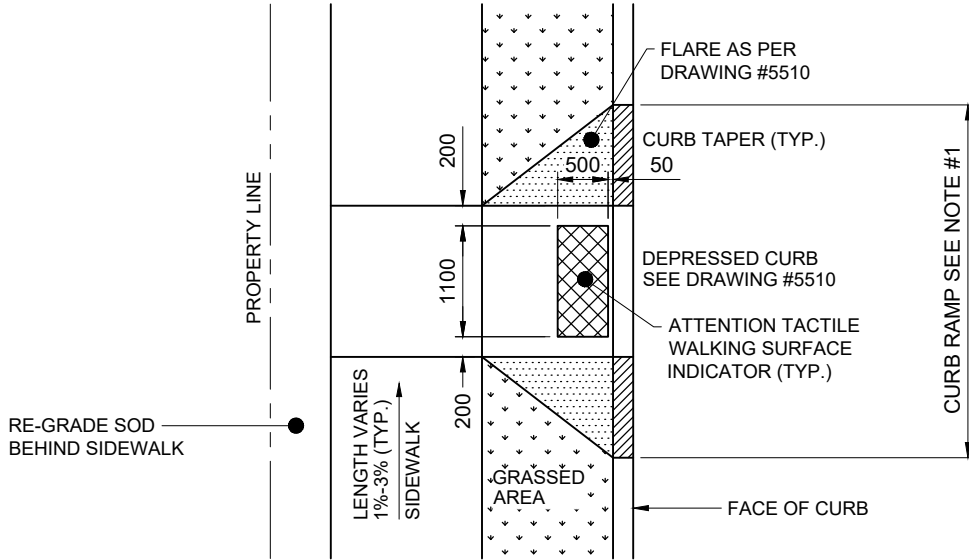

SEPARATED SIDEWALK

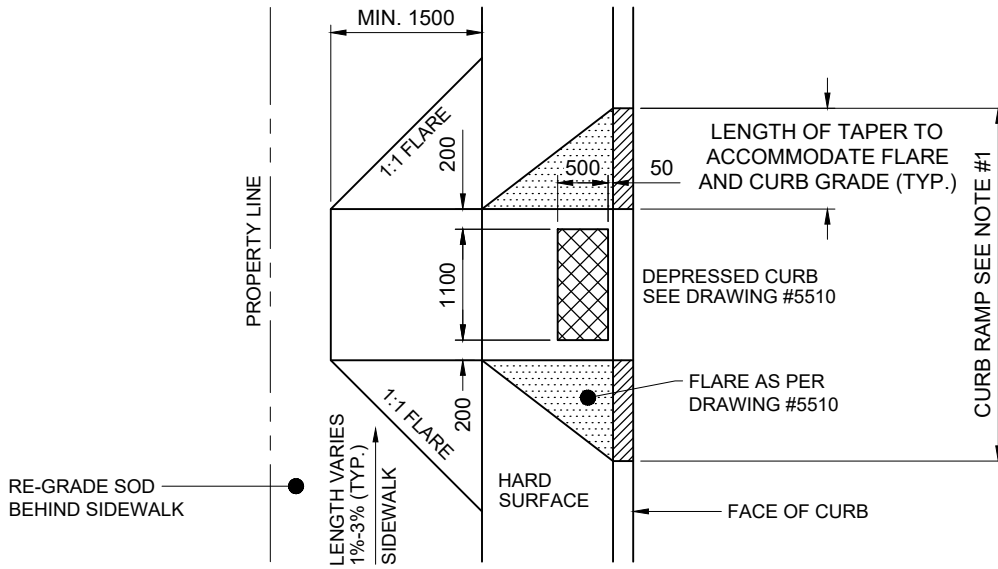

MONOLITHIC SIDEWALK

NOTE:

1. FULL DEPTH SAWCUT REQUIRED THROUGH THE STREET SLAB ALONG CURB RAMP. SEE DRAWING #5510

**ALL DIMENSIONS
IN MILLIMETRES UNLESS
OTHERWISE NOTED**

STANDARD DRAWING

**TACTILE WALKING SURFACE INDICATOR (TWSI)
LAYOUT FOR MID-BLOCK CROSSING**

DATE APPROVED: **2025**
SCALE: **N.T.S.**

DRAWN BY: **FR**
CHECKED BY: **JN**

APPROVED: *[Signature]*

DRAWING NUMBER: **5522**

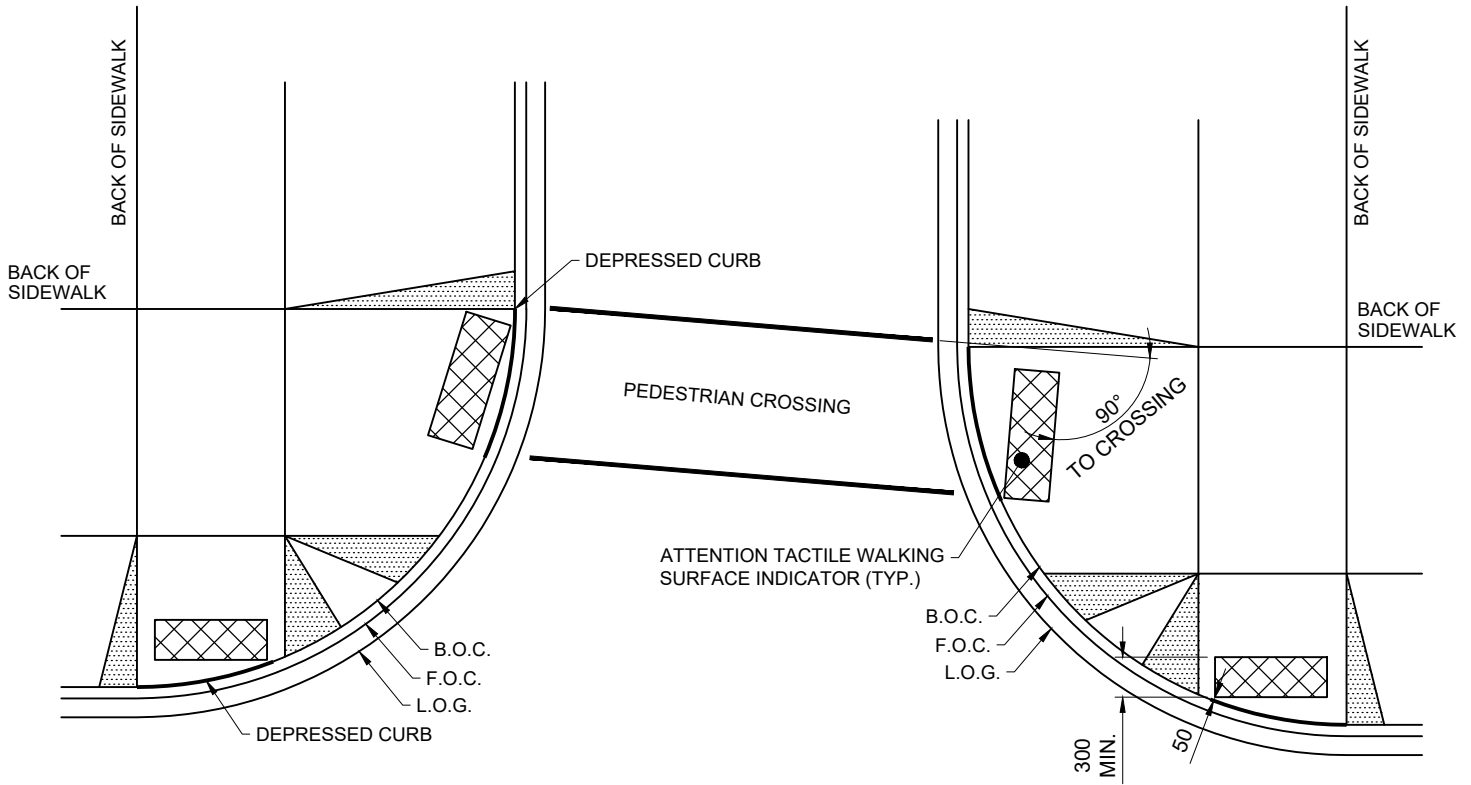

NOTE:

- 1. LOCATE END OF DEPRESSED CURB IN LINE WITH PROJECTED BACK OF SIDEWALK.

**ALL DIMENSIONS
IN MILLIMETRES UNLESS
OTHERWISE NOTED**



STANDARD DRAWING

**TACTILE WALKING SURFACE INDICATOR (TWSI)
ORIENTATION FOR OFFSET INTERSECTIONS**

DATE APPROVED: **2025**
SCALE: **N.T.S.**

DRAWN BY: **FR**
CHECKED BY: **JN**

APPROVED: *[Signature]*

DRAWING NUMBER: **5523**

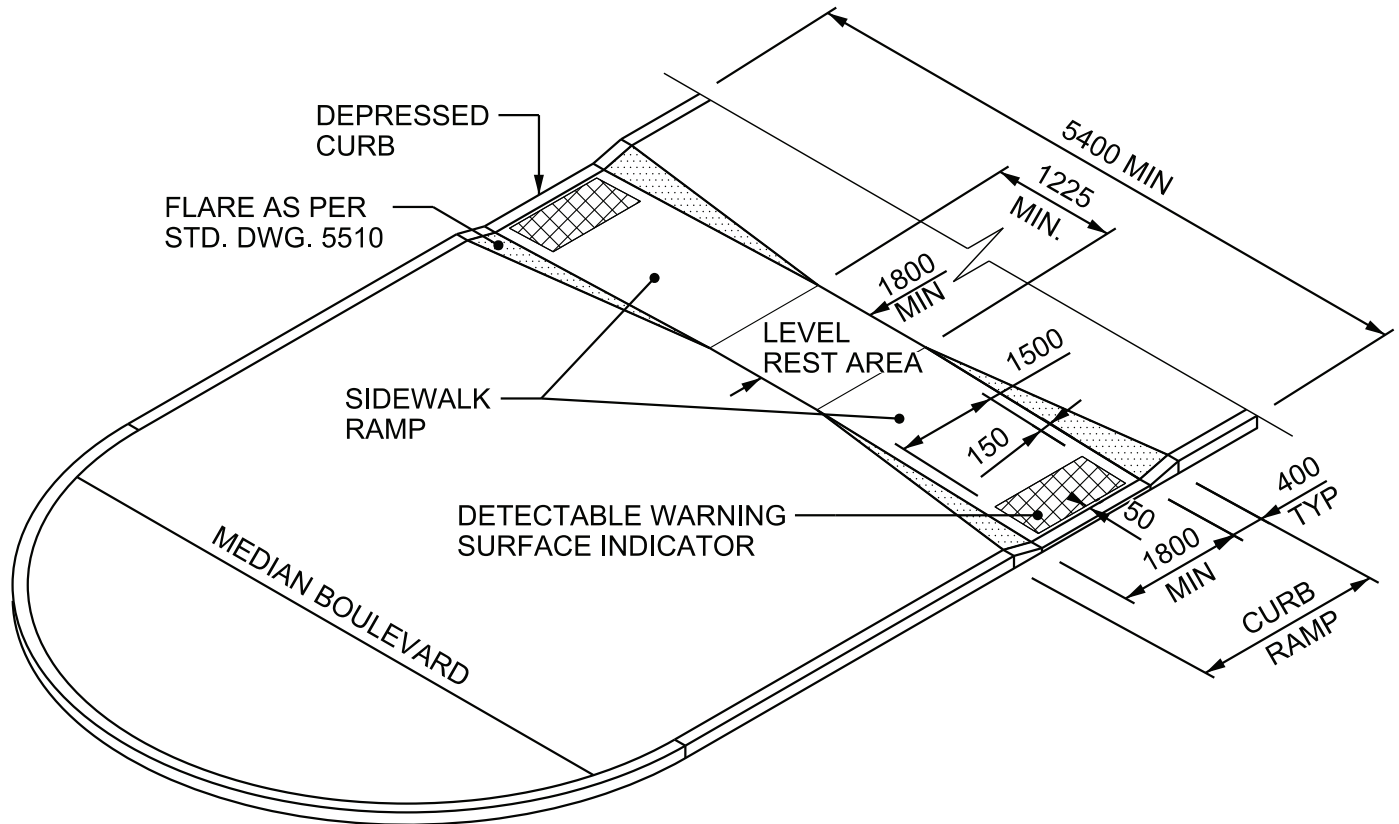

MEDIAN SIDEWALK CROSSING

**ALL DIMENSIONS
IN MILLIMETRES UNLESS
OTHERWISE NOTED**



STANDARD DRAWING

**TACTILE WALKING SURFACE INDICATOR (TWSI)
MEDIAN DETAIL**

DATE APPROVED: **2018**

DRAWN BY: **KSYC**

APPROVED: *M.R.*

DRAWING NUMBER: **5524**

SCALE: **N.T.S.**

CHECKED BY: **JN**

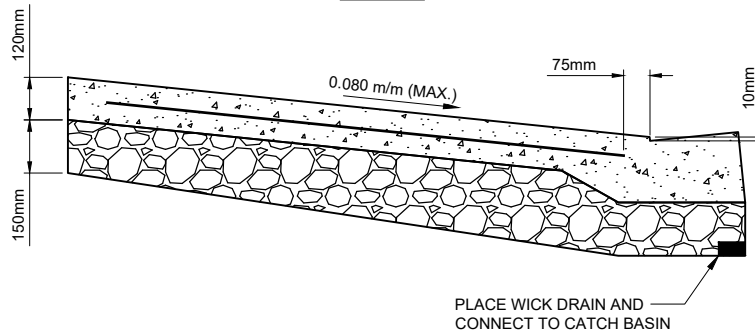
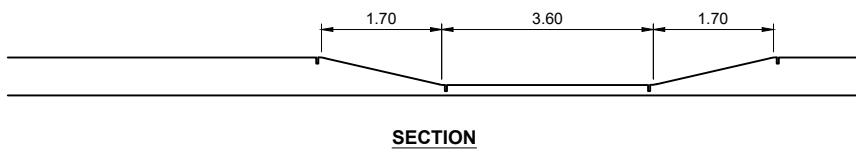
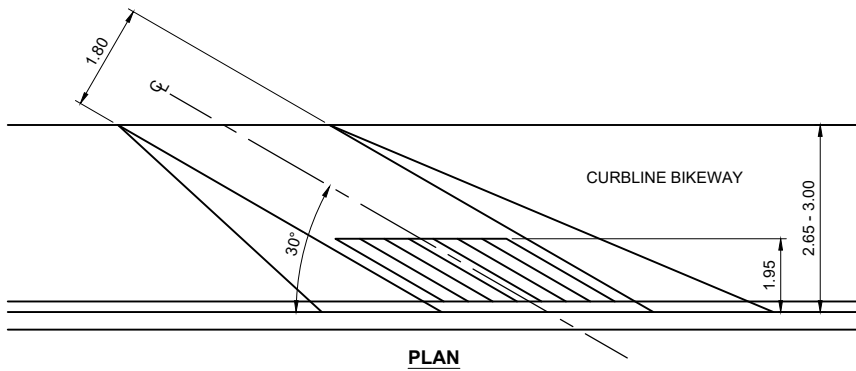
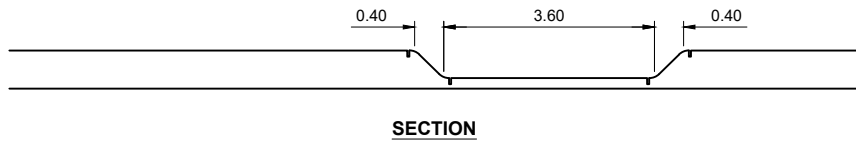
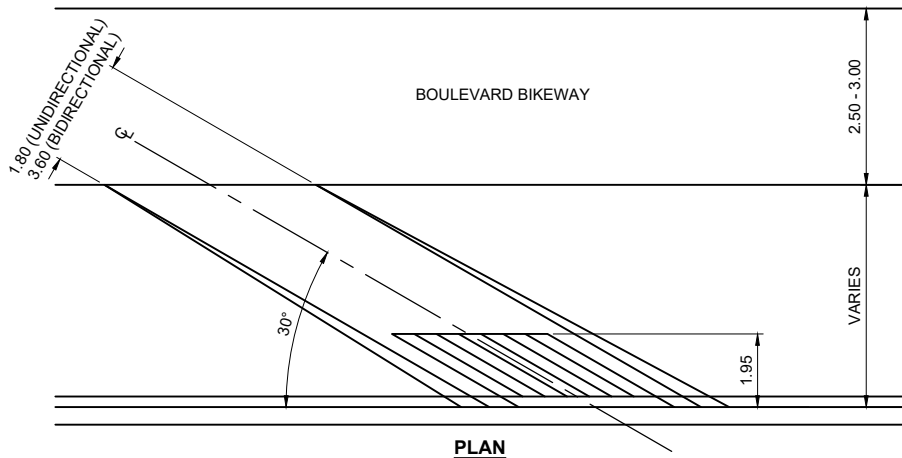

NOTE:

1. REPLACE CURBLINE BIKEWAY TO NEAREST JOINTS.
2. CURB AND RAMP TO BE POURED MONOLITHICALLY.
3. BROOMED FINISH. TOOLED GROOVES 5mm WIDE x 10mm DEEP, SPACED 150mm o.c.

**ALL DIMENSIONS
IN METRES UNLESS
OTHERWISE NOTED**

STANDARD DRAWING

MID-BLOCK BIKEWAY SLIP RAMP

DATE APPROVED: **2025**

SCALE: **N.T.S.**

DRAWN BY: **FR**

CHECKED BY: **JN**

APPROVED: *[Signature]*

DRAWING NUMBER: **5600**

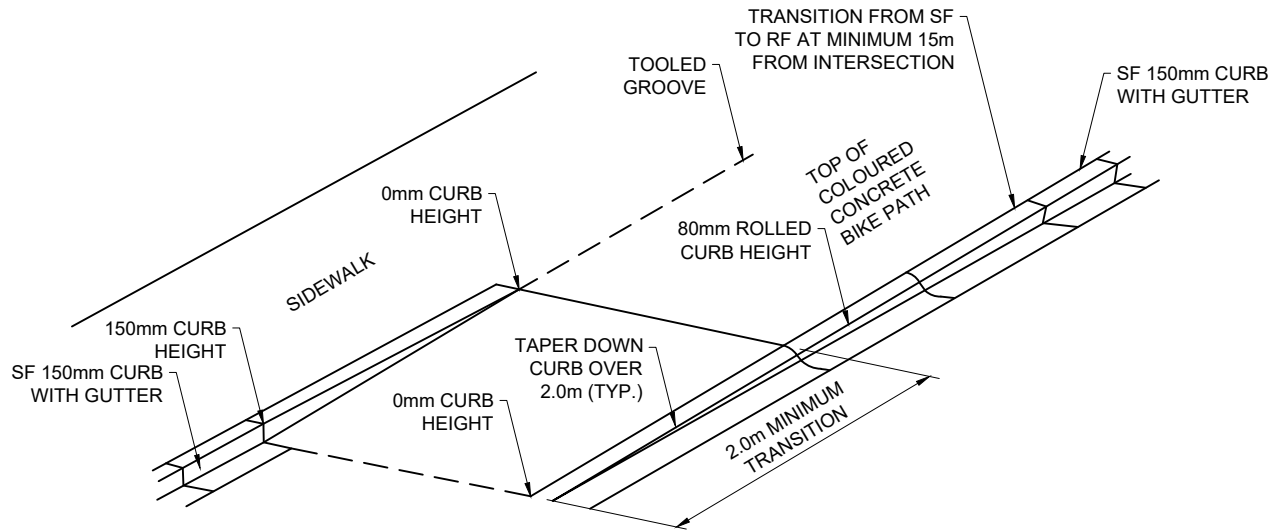

BIKE LANE END RAMP

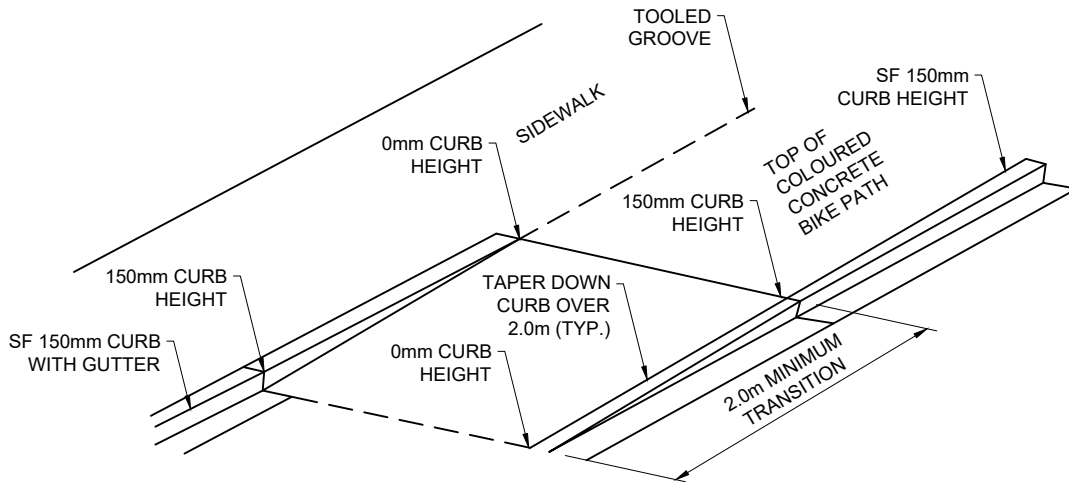

BIKE LANE START RAMP

**ALL DIMENSIONS
IN METRES UNLESS
OTHERWISE NOTED**

BIKE RAMP DETAIL



STANDARD DRAWING

DATE APPROVED: **2025**

DRAWN BY: **FR**

APPROVED: *[Signature]*

DRAWING NUMBER: **5605**

SCALE: **N.T.S.**

CHECKED BY: **JN**

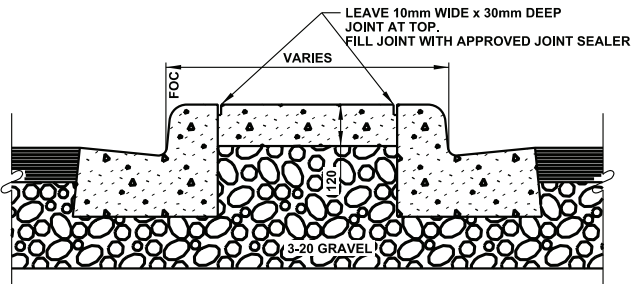
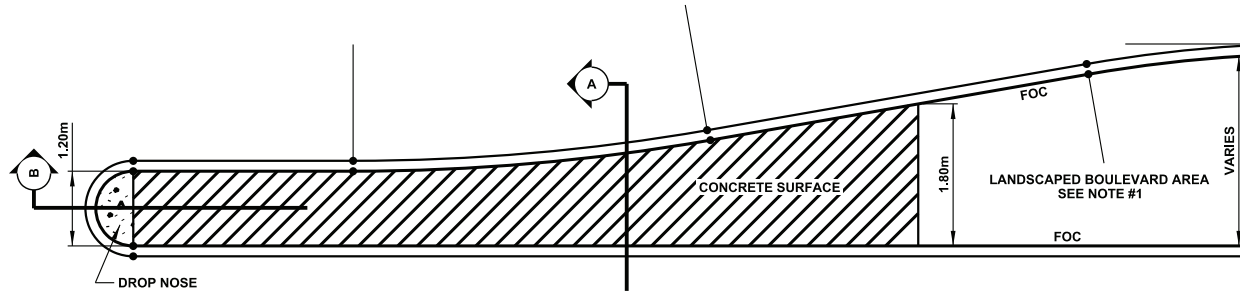

SECTION A-A

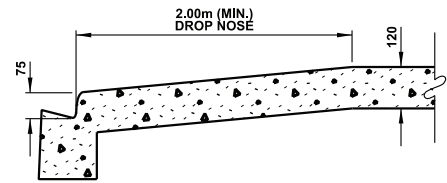

SECTION B-B

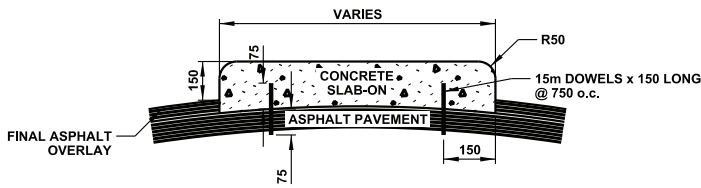

SECTION A-A

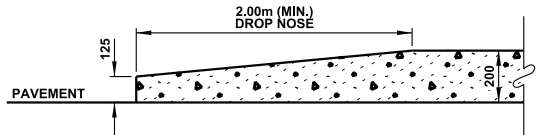

SECTION B-B

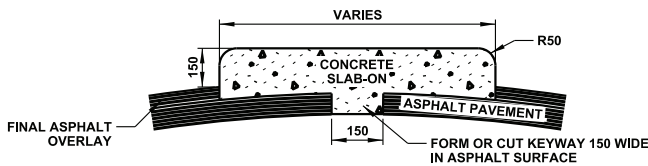

SECTION A-A

NOTE:

1. CONCRETE HEADER WITH CURB AND GUTTER IS REQUIRED WITHIN MEDIAN LANDSCAPED BOULEVARD AREA.

ALL DIMENSIONS
IN MILLIMETRES UNLESS
OTHERWISE NOTED



STANDARD DRAWING

CENTRE MEDIAN
END TREATMENT

DATE APPROVED: 2018

DRAWN BY: KSYC

APPROVED: *M.R.*

DRAWING NUMBER: 5610

SCALE: N.T.S.

CHECKED BY: JN

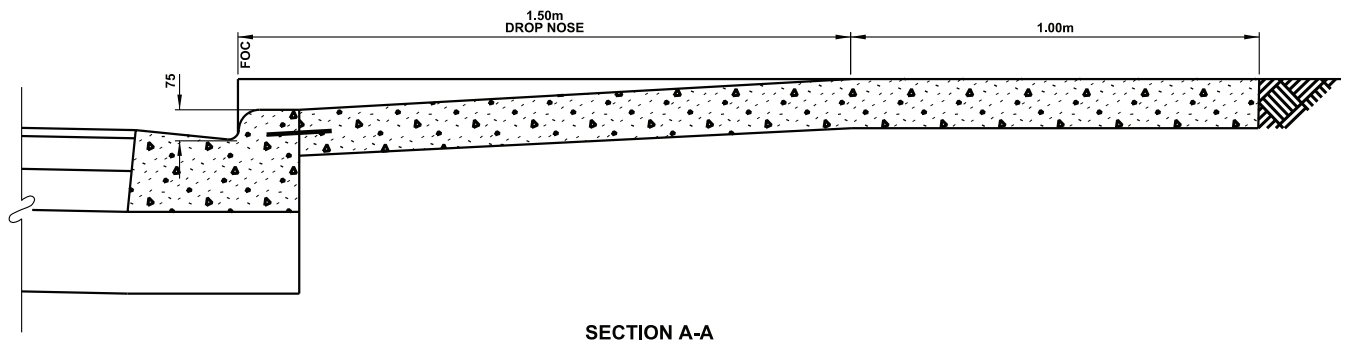
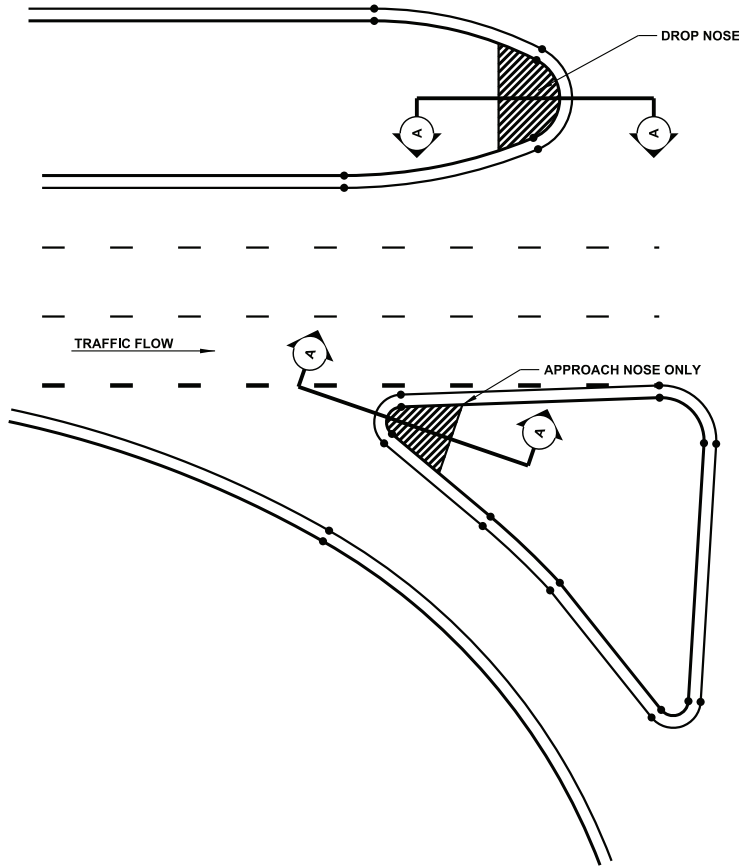

**ALL DIMENSIONS
IN MILLIMETRES UNLESS
OTHERWISE NOTED**



STANDARD DRAWING

**WIDE MEDIAN
END TREATMENT**

DATE APPROVED: **2018**

DRAWN BY: **KSYC**

APPROVED: *M.R.*

DRAWING NUMBER: **5620**

SCALE: **N.T.S.**

CHECKED BY: **JN**

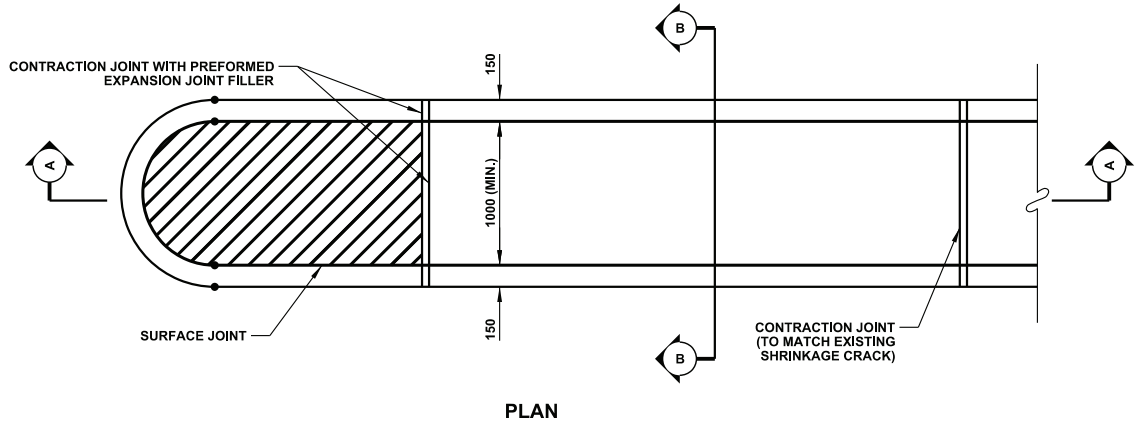

PLAN

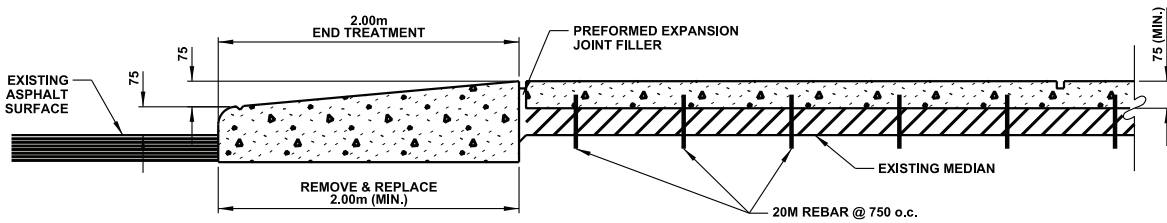

SECTION A-A

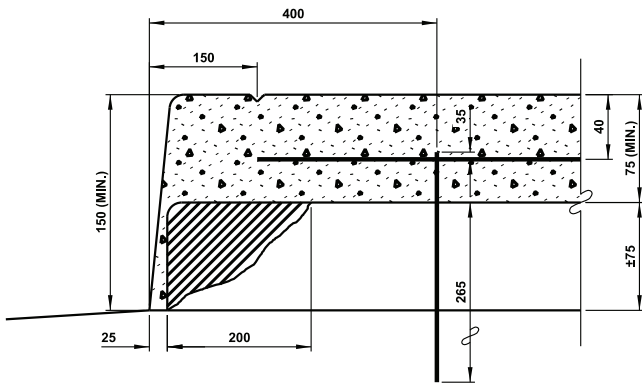

DETAIL 'C'

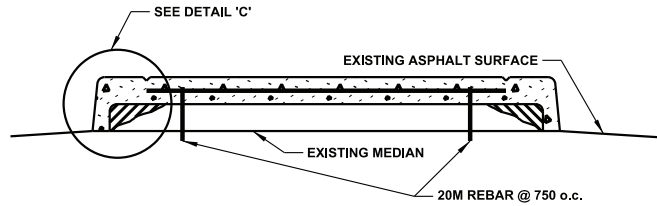

SECTION B-B

NOTES:

1. PREFORMED EXPANSION JOINT FILLER SHOULD ALSO BE PLACED AT MATCH TO EXISTING ISLAND.

**ALL DIMENSIONS
IN MILLIMETRES UNLESS
OTHERWISE NOTED**



STANDARD DRAWING

**CENTER MEDIAN
REHABILITATION**

DATE APPROVED: **2018**

DRAWN BY: **KSYC**

APPROVED: *M.R.*

DRAWING NUMBER: **5630**

SCALE: **N.T.S.**

CHECKED BY: **JN**

ALL DIMENSIONS
IN METRES UNLESS
OTHERWISE NOTED

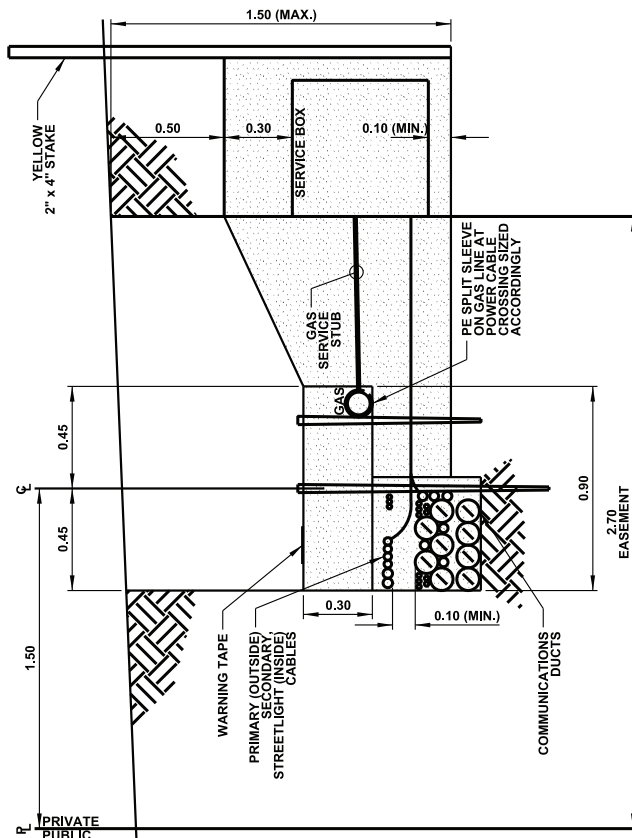

SERVICE TRENCH

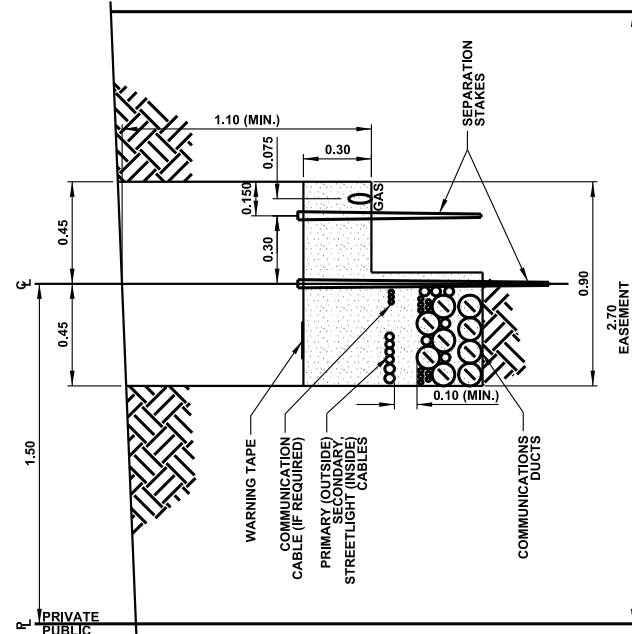

MAIN TRENCH DETAIL

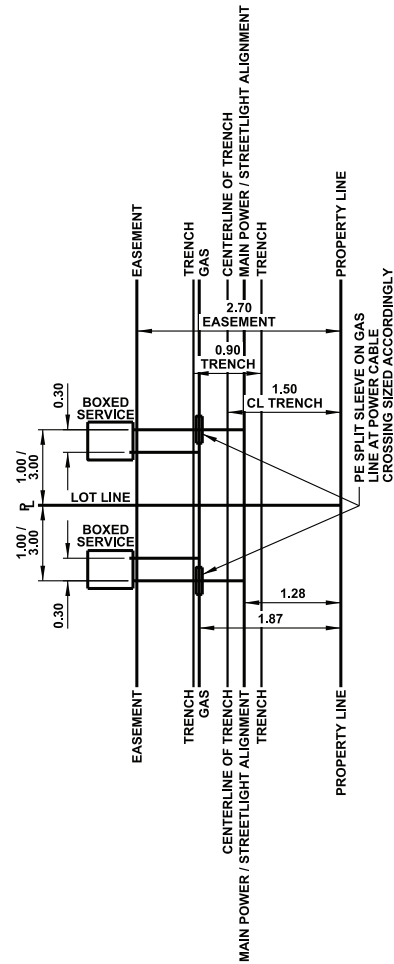

LOT SERVICE DETAIL

NOTES:

1. 1.50m MAXIMUM DEPTH TO THE BOTTOM OF POWER CABLES.



STANDARD DRAWING

MULTI-PARTY UTILITIES TRENCHING

DATE APPROVED: **2018**

DRAWN BY: **KSYC**

APPROVED: *M.R.*

DRAWING NUMBER: **5700**

SCALE: **N.T.S.**

CHECKED BY: **JN**



Standard Drawings

SECTION 6000 / 7000 – MISCELLANEOUS

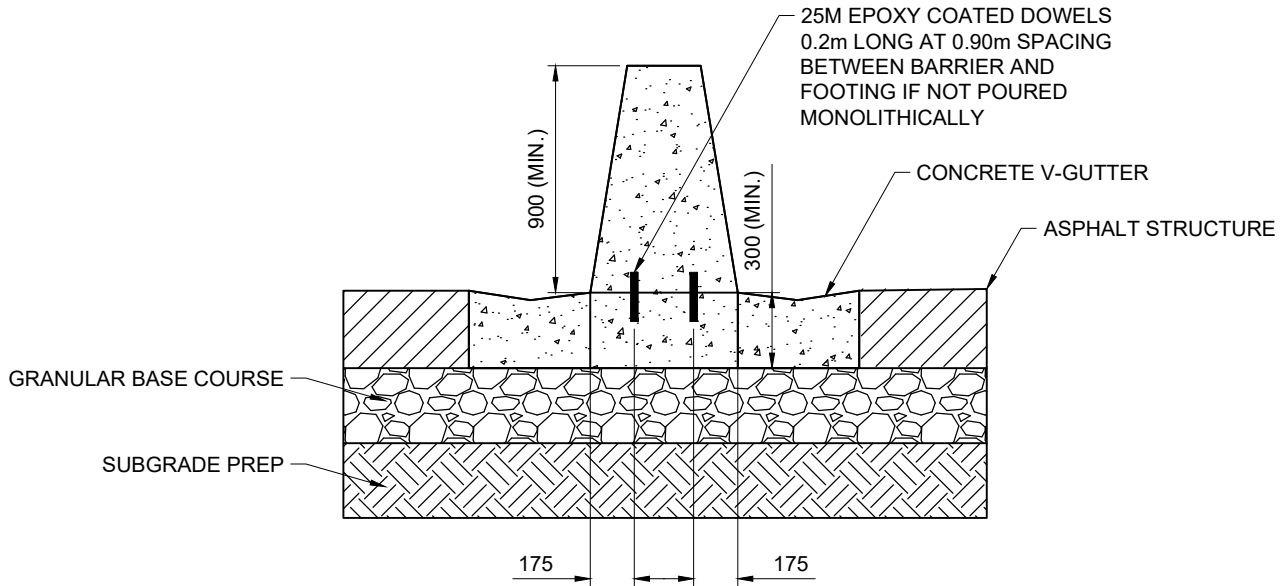

SINGLE SLOPE CONCRETE BARRIER WITH V-GUTTER

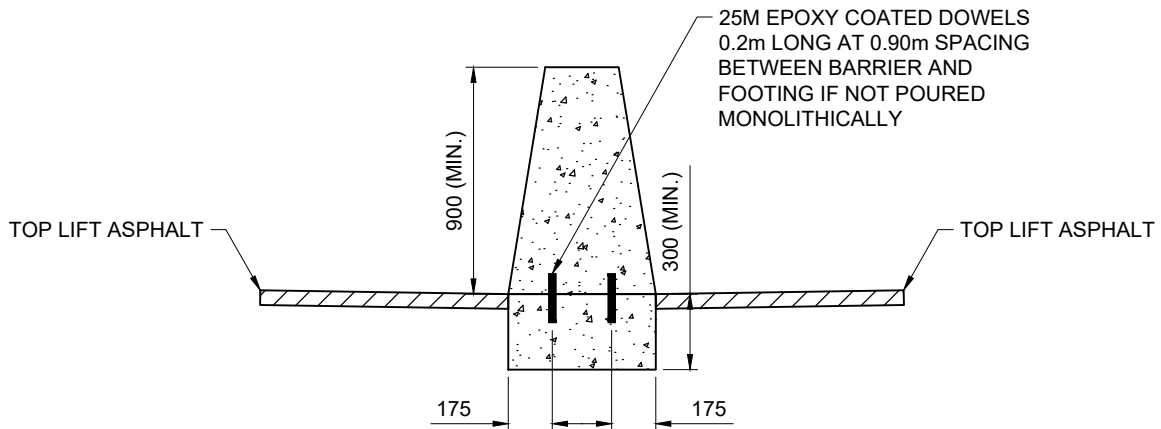

SINGLE SLOPE CONCRETE BARRIER WITHOUT V-GUTTER

**ALL DIMENSIONS
IN MILLIMETRES UNLESS
OTHERWISE NOTED**

SINGLE SLOPE CONCRETE BARRIERS



STANDARD DRAWING

DATE APPROVED: **2025**

DRAWN BY: **FR**

APPROVED:

DRAWING NUMBER: **6001**

SCALE: **N.T.S.**

CHECKED BY: **JN**

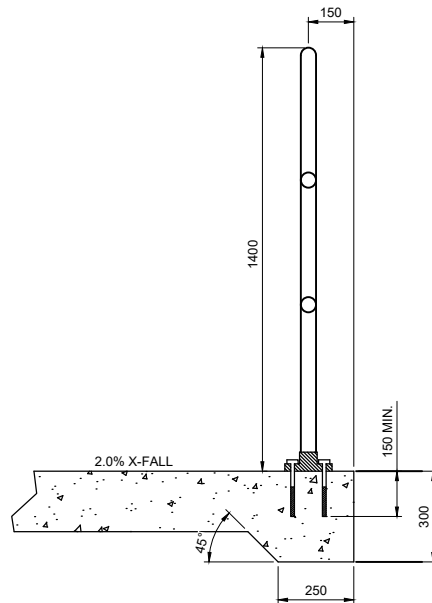
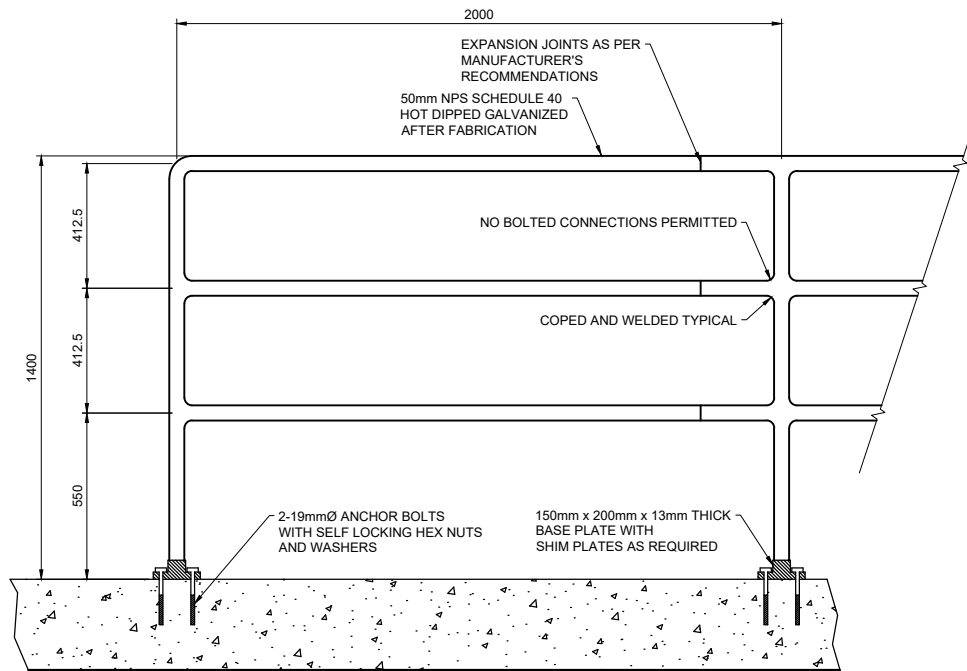

**ALL DIMENSIONS
IN MILLIMETRES UNLESS
OTHERWISE NOTED**

HANDRAIL DETAILS



STANDARD DRAWING

DATE APPROVED: **2025**

DRAWN BY: **FR**

APPROVED: *[Signature]*

DRAWING NUMBER: **6085**

SCALE: **N.T.S.**

CHECKED BY: **JN**

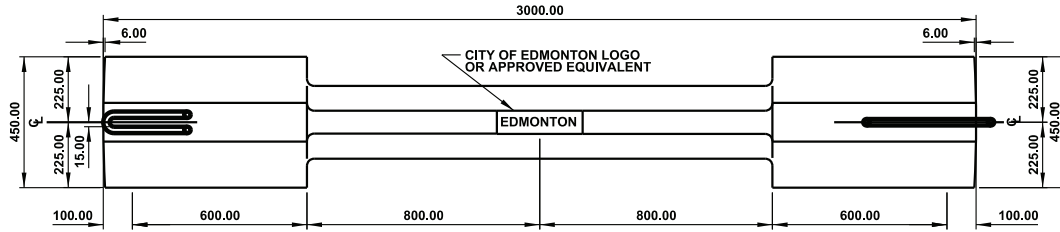

PLAN VIEW

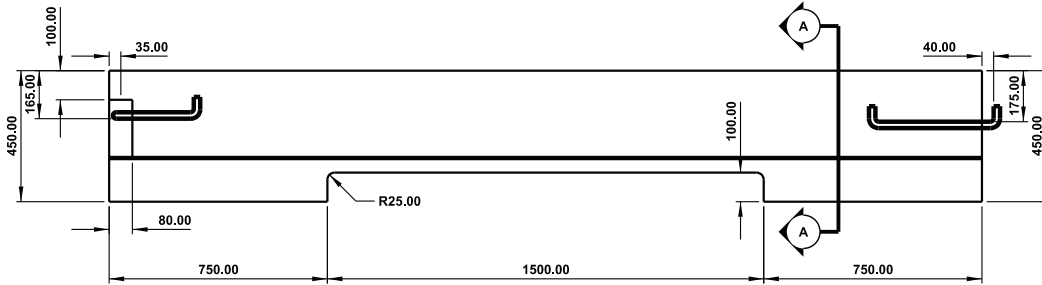

ELEVATION

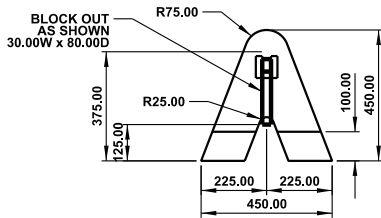

LEFT END VIEW

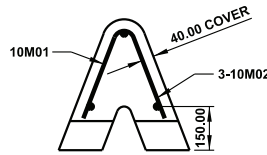

SECTION A-A

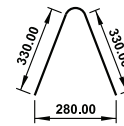

10M01

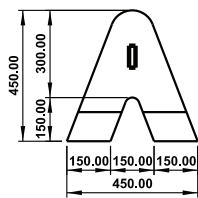

RIGHT END VIEW

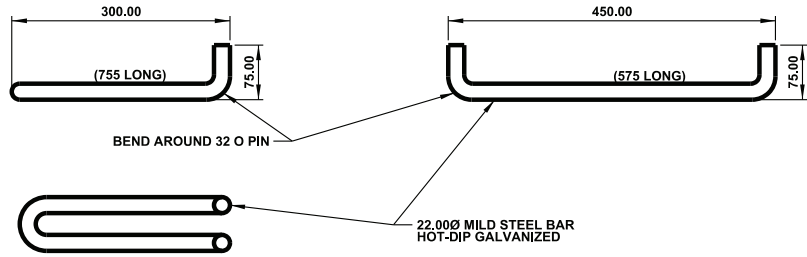

STEEL BAR DETAIL

NOTES:

1. CLASS "C" CONCRETE

ALL DIMENSIONS
IN MILLIMETRES UNLESS
OTHERWISE NOTED



STANDARD DRAWING

PRE-CAST CONCRETE MINI-BARRIER

DATE APPROVED: 2018

DRAWN BY: KSYC

APPROVED: *M.A.R.*

DRAWING NUMBER: 6100

SCALE: N.T.S.

CHECKED BY: JN

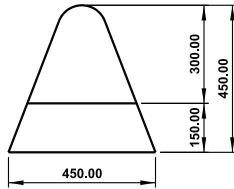

LEFT END VIEW

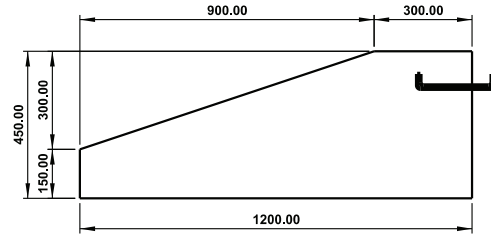

ELEVATION

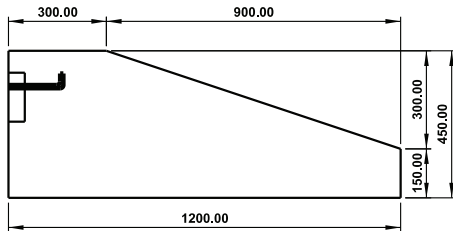

ELEVATION

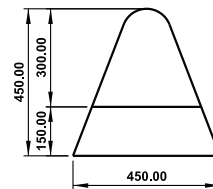

RIGHT END VIEW

NOTES:

- 1. CLASS "C" CONCRETE.
- 2. FOR STEEL DETAIL SEE DRAWING #6100.

**ALL DIMENSIONS
IN MILLIMETRES UNLESS
OTHERWISE NOTED**



STANDARD DRAWING

END TRANSITION PRE-CAST CONCRETE MINI-BARRIER

DATE APPROVED: **2018**

DRAWN BY: **KSYC**

APPROVED: *M.R.*

DRAWING NUMBER: **6101**

SCALE: **N.T.S.**

CHECKED BY: **JN**

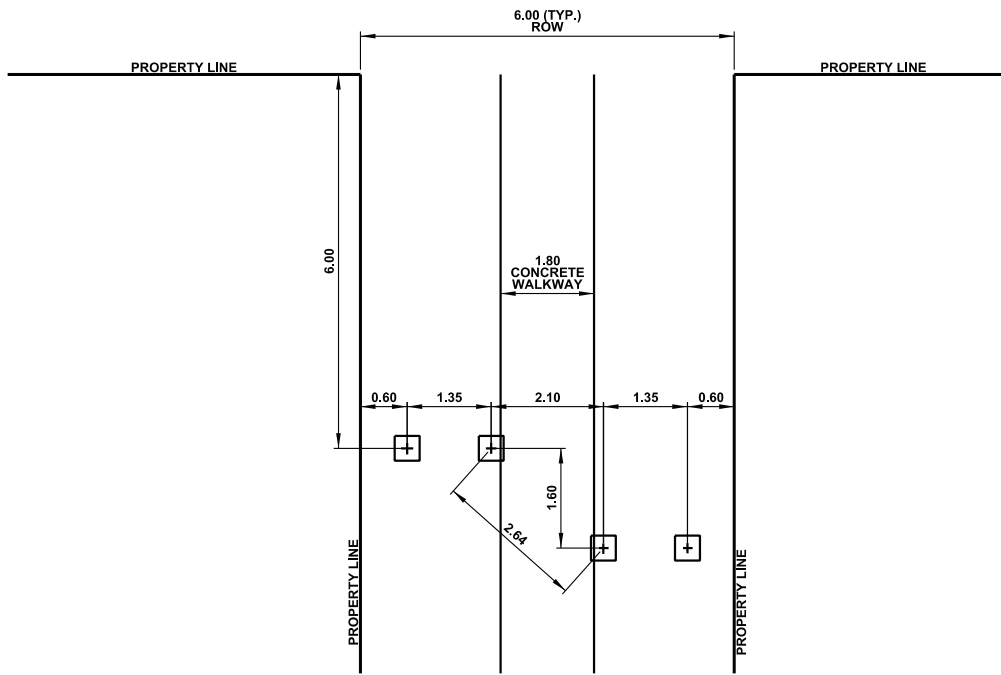

TYPICAL BOLLARD LAYOUT

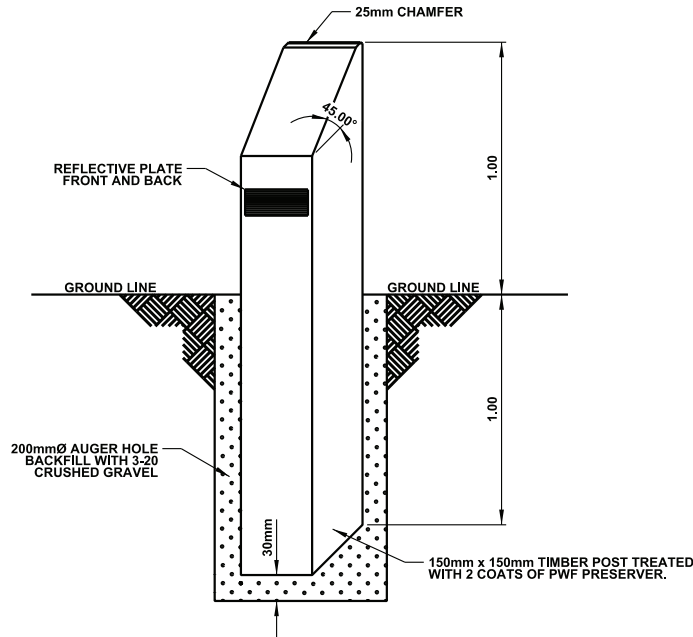

BOLLARD DETAIL

LEGEND:

☒ BOLLARD

NOTES:

- HAND TREAT ALL CUTS WITH PWF PRESERVER.
- REQUIREMENT AND LOCATION OF BOLLARDS ARE SUBJECT TO CITY OF EDMONTON APPROVAL.

ALL DIMENSIONS IN METRES UNLESS OTHERWISE NOTED



STANDARD DRAWING

TYPICAL BOLLARD LAYOUT AND INSTALLATION FOR 1.80m CONCRETE WALKWAYS

DATE APPROVED: 2018

DRAWN BY: KSYC

APPROVED: *M.A.R.*

DRAWING NUMBER: 6200

SCALE: N.T.S.

CHECKED BY: JN

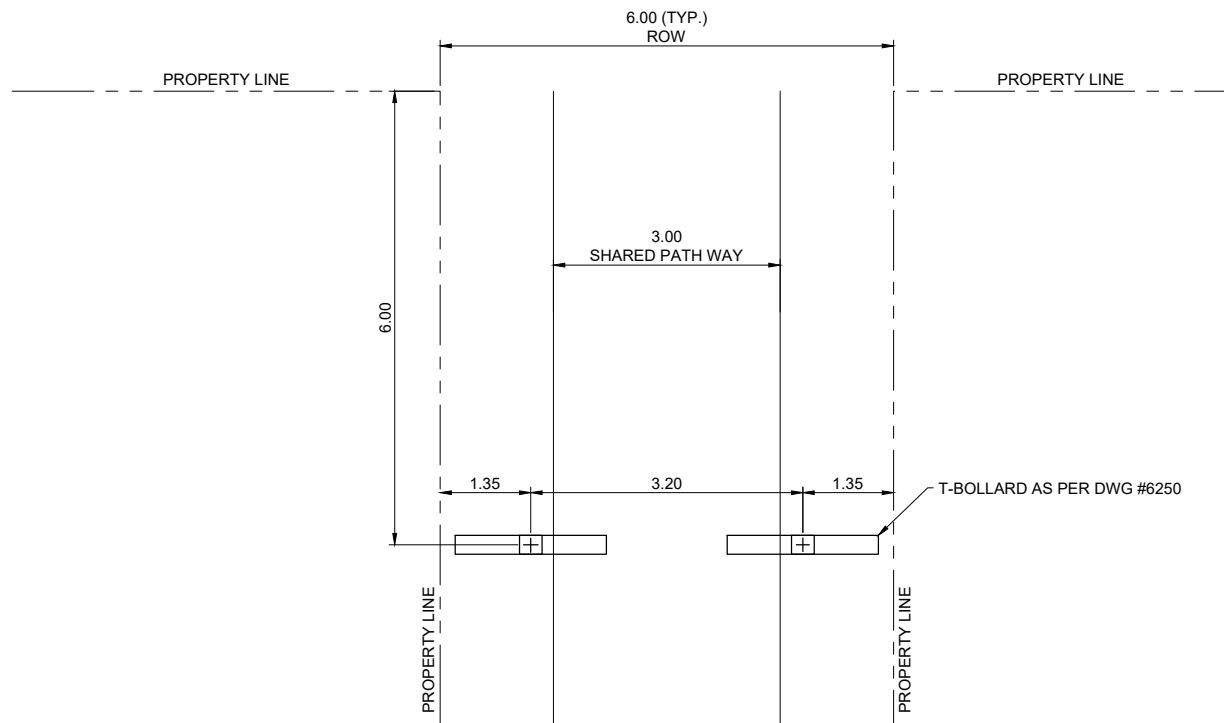

TYPICAL BOLLARD LAYOUT

LEGEND:

+	T-BOLLARD
---	-----------

NOTE:

1. REQUIREMENT AND LOCATION OF BOLLARDS ARE SUBJECT TO CITY OF EDMONTON APPROVAL.

**ALL DIMENSIONS
IN METRES UNLESS
OTHERWISE NOTED**



STANDARD DRAWING

**TYPICAL BOLLARD LAYOUT AND INSTALLATION
FOR 3.00m SHARED PATHWAY**

DATE APPROVED: **2025**

SCALE: **N.T.S.**

DRAWN BY: **FR**

CHECKED BY: **JN**

APPROVED: 

DRAWING NUMBER: **6210**

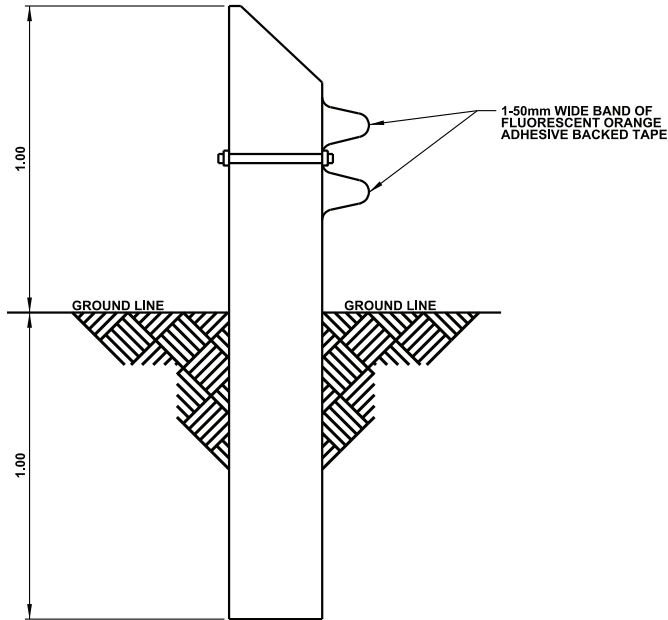
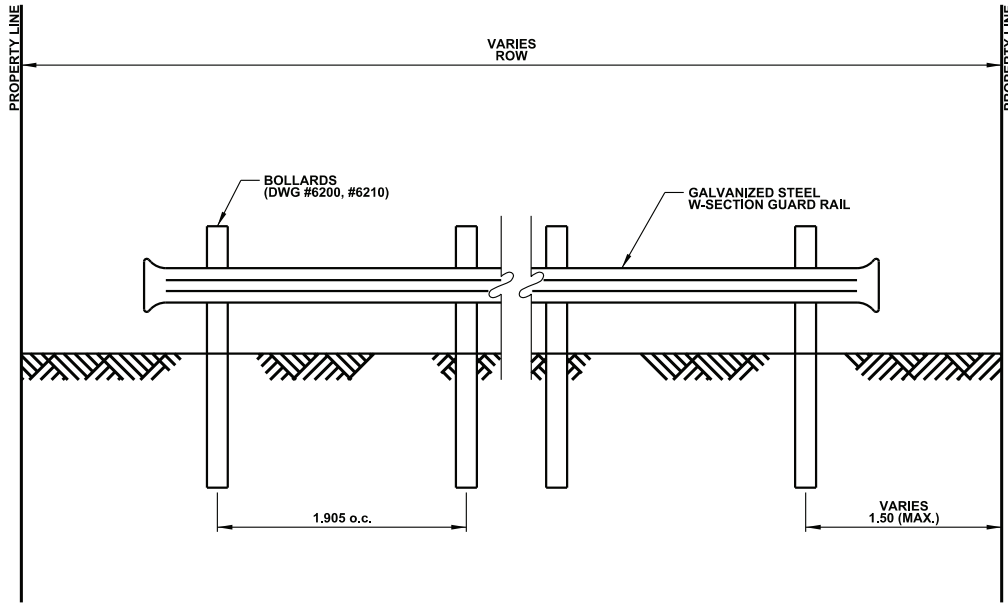

NOTES:

- 1. ALL HARDWARE TO BE GALVANIZED.

**ALL DIMENSIONS
IN METRES UNLESS
OTHERWISE NOTED**

**TYPICAL BOLLARD WITH
GALVANIZED STEEL W-SECTION**



STANDARD DRAWING

DATE APPROVED: **2018**

DRAWN BY: **KSYC**

APPROVED: *M.A.R.*

DRAWING NUMBER: **6220**

SCALE: **N.T.S.**

CHECKED BY: **JN**

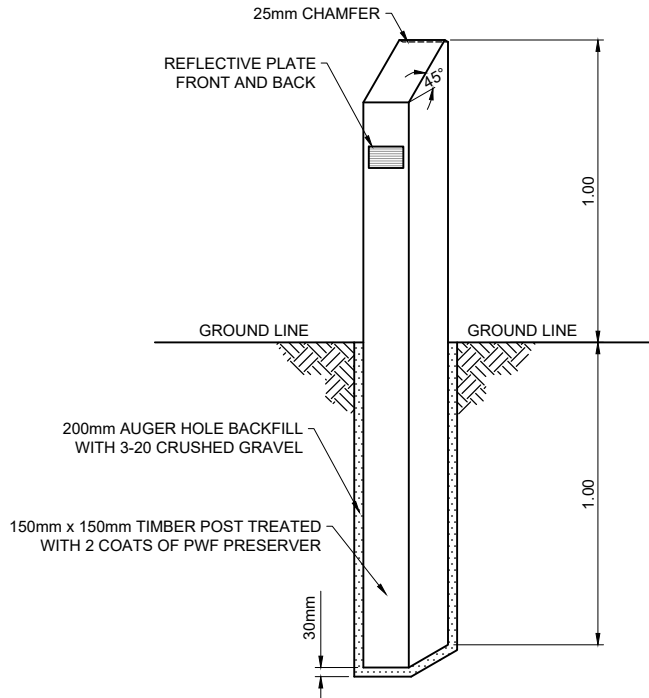
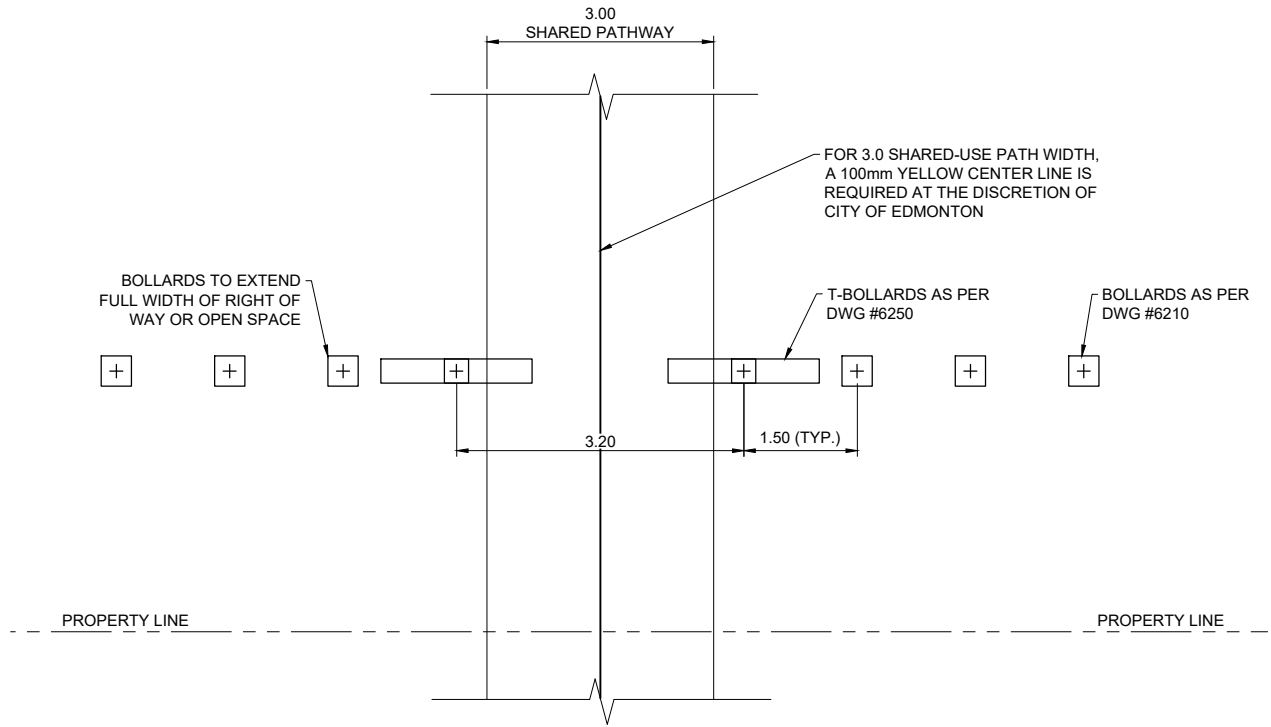

BOLLARD DETAIL

LEGEND:

-  BOLLARD
-  T-BOLLARD

NOTE:

1. HAND TREAT ALL CUTS WITH PWF PRESERVER.
2. REQUIREMENT AND LOCATION OF CENTER BOLLARD WITHIN SHARED PATHWAY IS SUBJECT TO CITY OF EDMONTON APPROVAL.

**ALL DIMENSIONS
IN METRES UNLESS
OTHERWISE NOTED**



STANDARD DRAWING

**TYPICAL BOLLARD LAYOUT
FOR 3.00m ASPHALT SHARED PATHWAY
WITHIN PIPELINE / POWER ROW / OPEN SPACE**

DATE APPROVED: **2025**

SCALE: **N.T.S.**

DRAWN BY: **FR**

CHECKED BY: **JN**

APPROVED: 

DRAWING NUMBER: **6230**

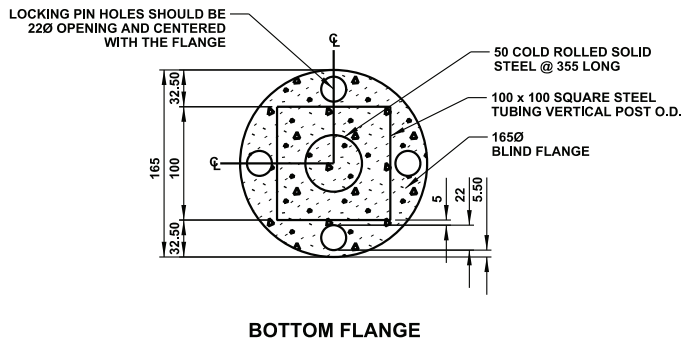
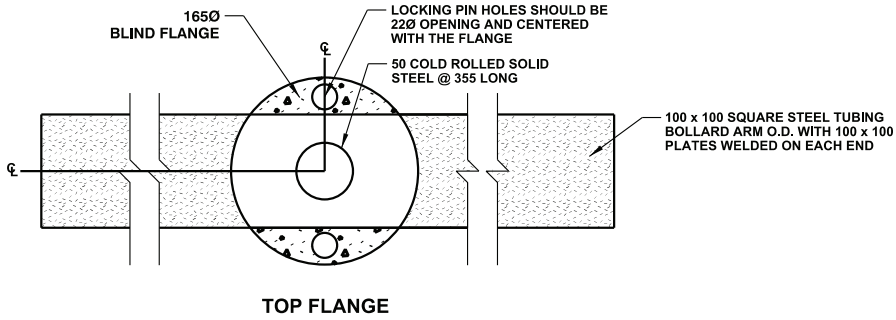
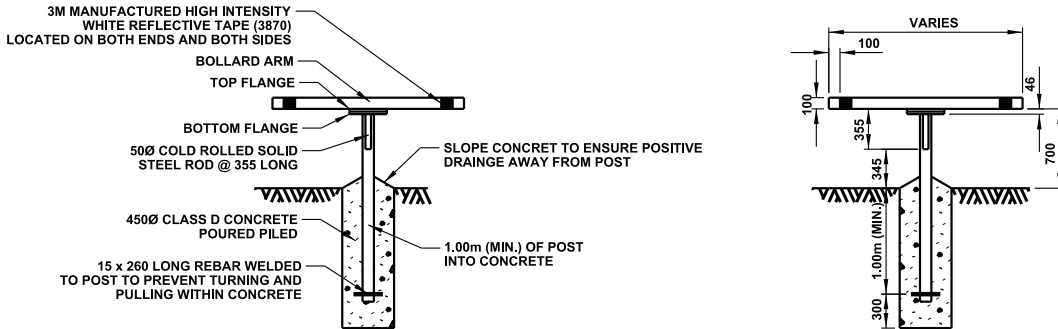
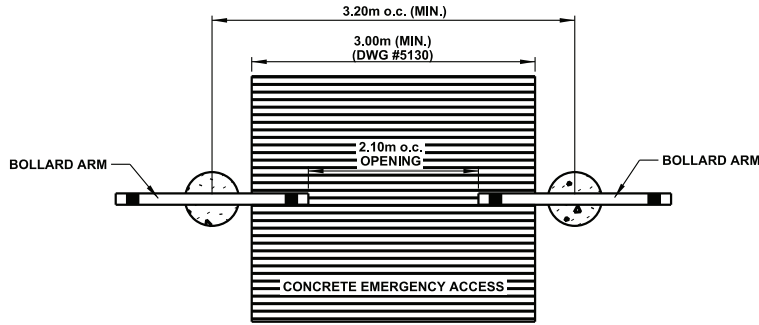

REFER TO DRAWING #6251 FOR T-BOLLARD ASSEMBLY DETAIL

ALL DIMENSIONS IN MILLIMETRES UNLESS OTHERWISE NOTED

NOTES:

1. ALL METAL TO BE GALVANIZED. (POWDER COATING OPTIONAL) COLOR TO BE APPROVED BY CITY OF EDMONTON.
2. USE OF T-BOLLARDS TO BE AT DISCRETION OF CITY OF EDMONTON.

T-BOLLARD IN EMERGENCY ACCESS



STANDARD DRAWING

DATE APPROVED: **2018**

DRAWN BY: **KSYC**

APPROVED: *M.A.R.*

DRAWING NUMBER: **6250**

SCALE: **N.T.S.**

CHECKED BY: **JN**

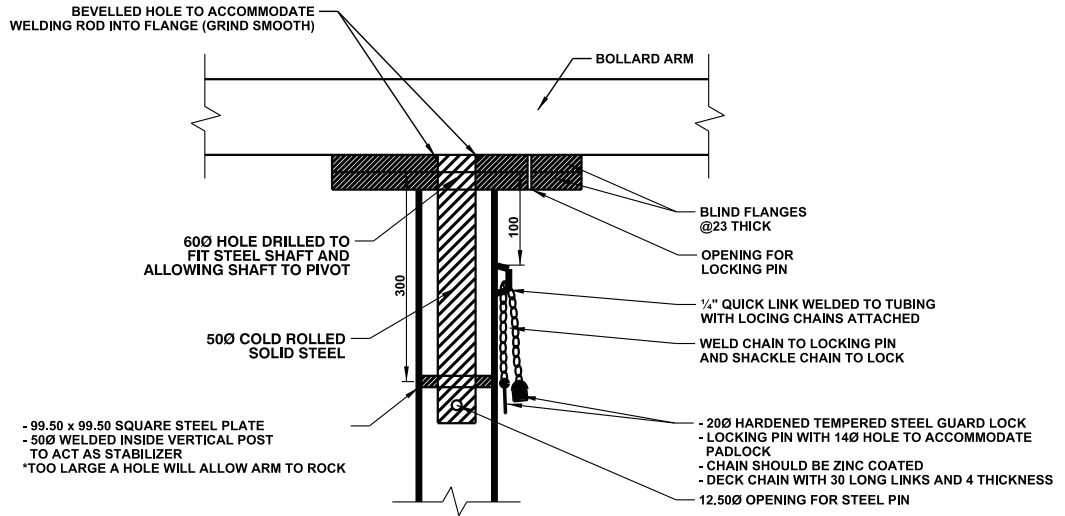

ASSEMBLY DETAIL

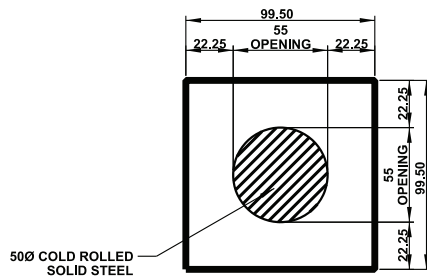
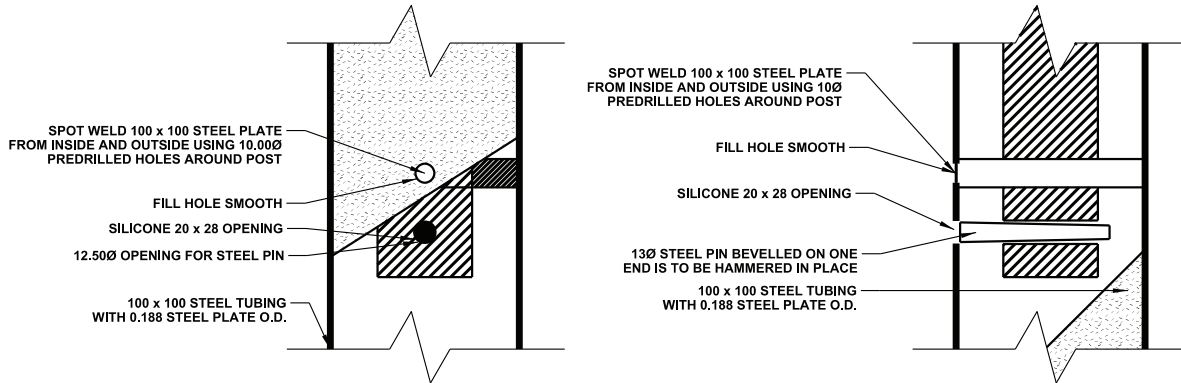

99.50 x 99.50 SQUARE STEEL PLATE

NOTES:

- 1. ALL METAL TO BE GALVANIZED. (POWDER COATING OPTIONAL) COLOR TO BE APPROVED BY CITY OF EDMONTON.

ALL DIMENSIONS IN MILLIMETRES UNLESS OTHERWISE NOTED

T-BOLLARD ASSEMBLY DETAIL



STANDARD DRAWING

DATE APPROVED: **2018**

DRAWN BY: **KSYC**

APPROVED: *M.R.*

DRAWING NUMBER: **6251**

SCALE: **N.T.S.**

CHECKED BY: **JN**

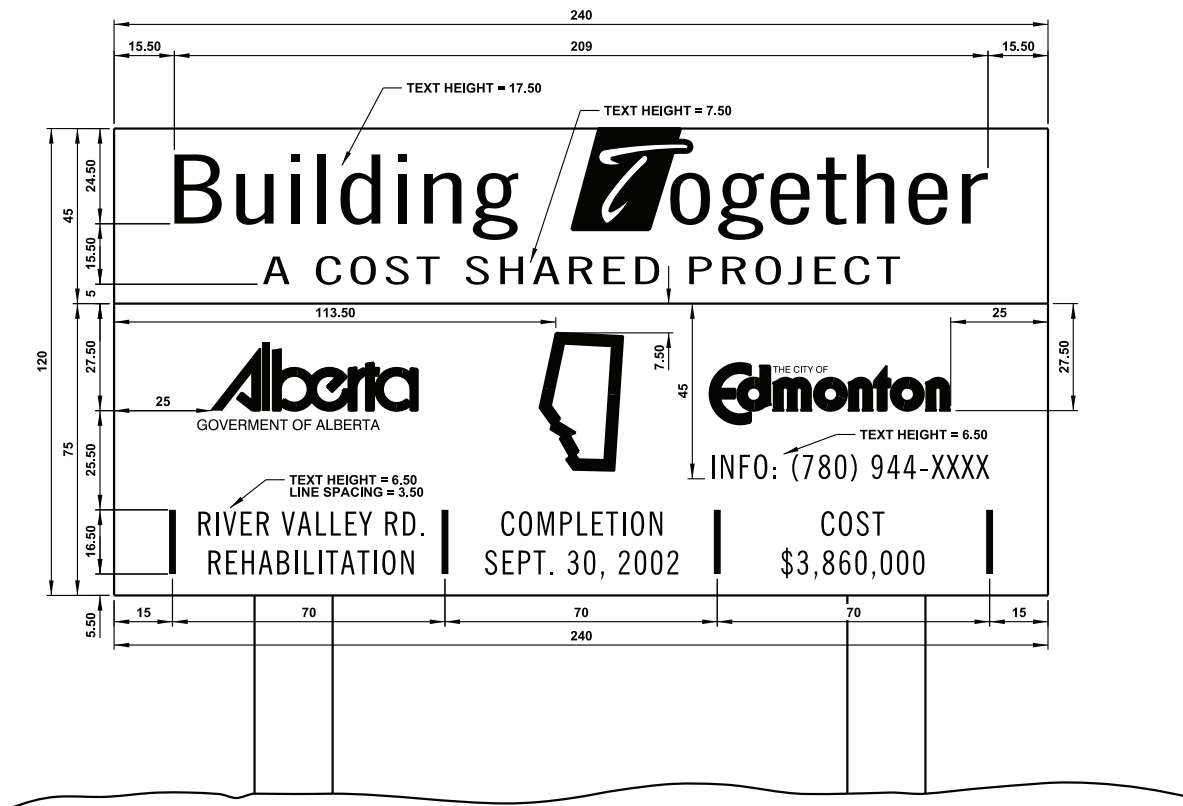

SIGNAGE SPECIFICATION:

DIMENSIONS: 240 x 120

MATERIAL: HIGH INTENSITY GRADE REFLECTIVE SHEETING
19mm HIGH DENSITY OVERLAY FIR PLYWOOD

COLOR: TOP: BACKGROUND - WHITE
MESSAGE - BLUE (PMS 286)
BOTTOM: BACKGROUND - BLUE (PMS 286)
MESSAGE - WHITE

LETTER STYLE: GILL SANS BOLD

NOTES: LETTER SPACING TO BE DETERMINED WHEN EACH SIGN IS FABRICATED

**ALL DIMENSIONS
IN CENTIMETRES UNLESS
OTHERWISE NOTED**



COST SHARE PROJECT SIGN

DATE APPROVED: **2018**
SCALE: **N.T.S.**

DRAWN BY: **KSYC**
CHECKED BY: **JN**

APPROVED: *M.L.R.*

DRAWING NUMBER: **6500**

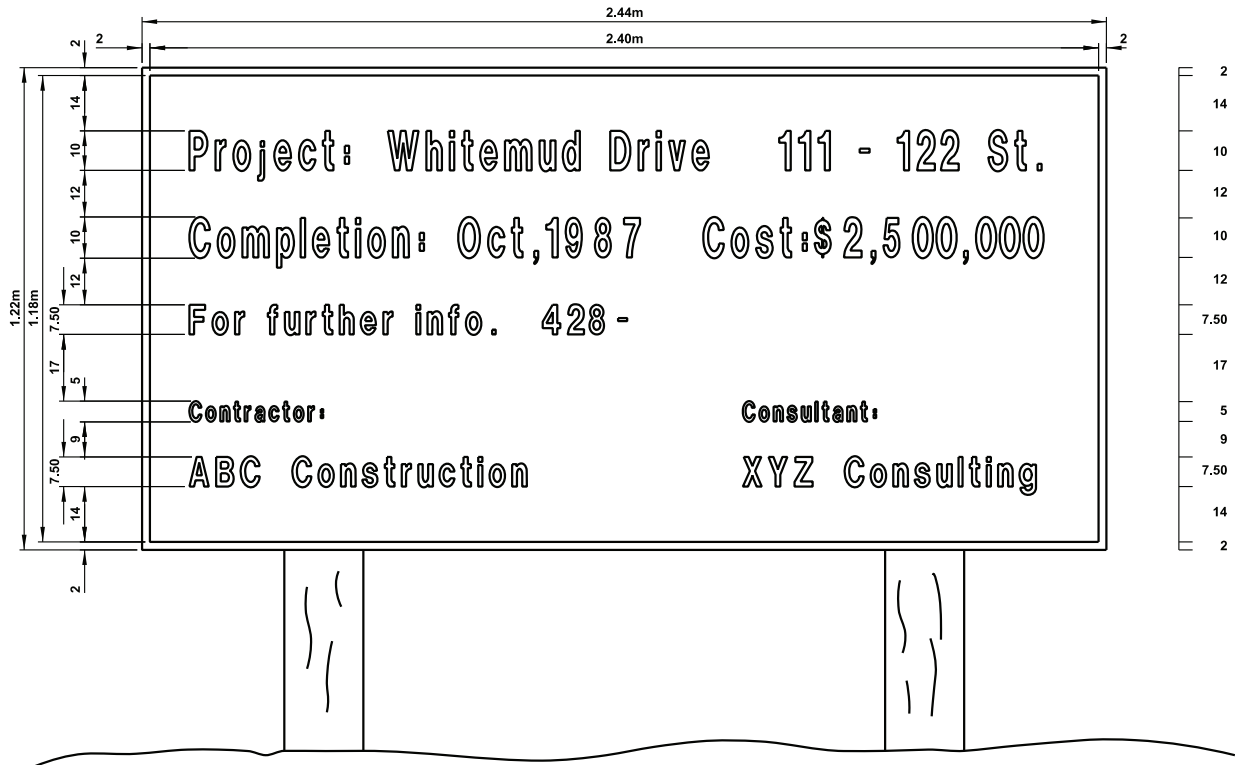

SIGNAGE SPECIFICATION:

DIMENSION: 240 x 120

MATERIALS: HIGH INTENSITY GRADE REFLECTIVE SHEETING 2870 - SILVER (SCOTCHLITE)
19mm HIGH DENSITY OVERLAY FIR PLYWOOD

INK: 810 TRANSPARENT BLUE 3M

COLOR: TRANSPARENT BLUE ON SILVER BACKGROUND

LETTER STYLE: COOPER BLACK ITALIC AND HELVETICA MEDIUM - SIZES AS SHOWN ABOVE

NOTES: LETTER SPACING TO BE DETERMINED WHEN EACH SIGN IS FABRICATED

COST: CONTRACT DOLLAR (\$) AMOUNT TO NEAREST 100,000

**ALL DIMENSIONS
IN CENTIMETRES UNLESS
OTHERWISE NOTED**



AUXILIARY PROJECT SIGN

DATE APPROVED: **2018**
SCALE: **N.T.S.**

DRAWN BY: **KSYC**
CHECKED BY: **JN**

APPROVED: *M.R.*

DRAWING NUMBER: **6510**

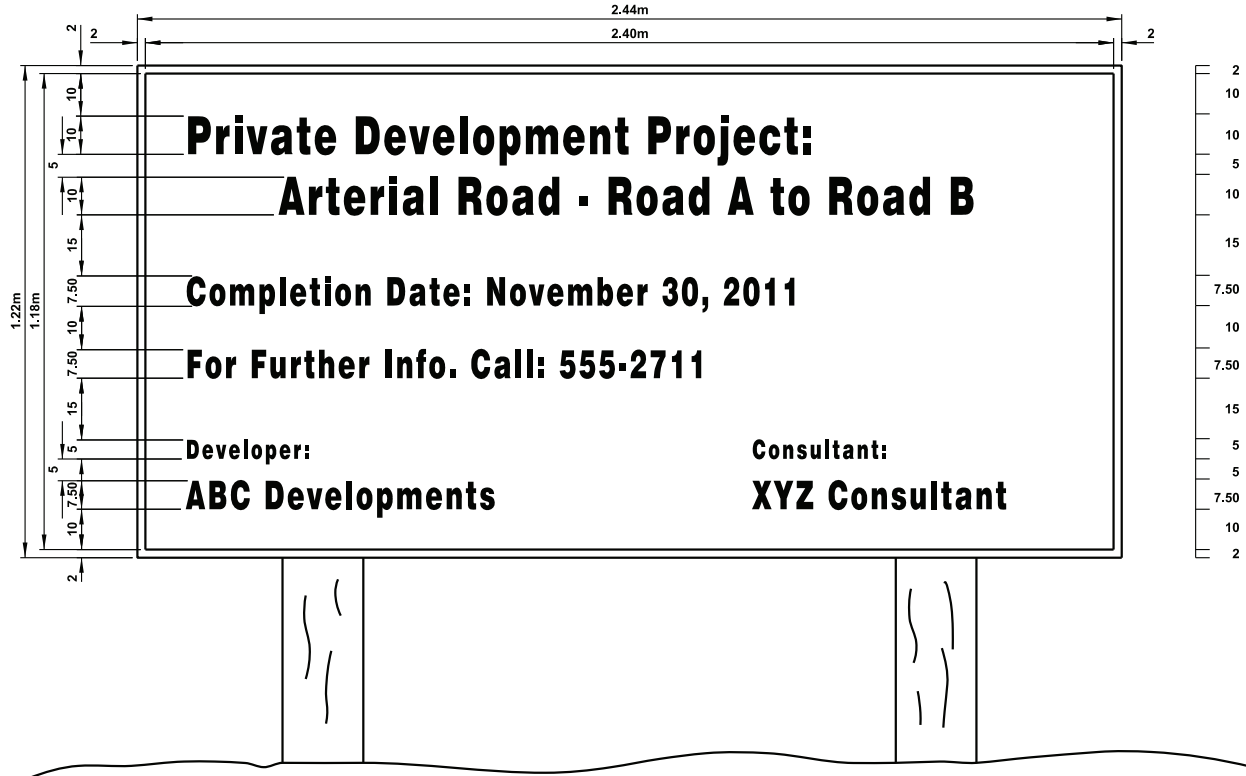

SIGNAGE SPECIFICATION:

DIMENSION: 240 x 120

MATERIALS: HIGH INTENSITY GRADE REFLECTIVE SHEETING 3870 - SILVER (HIGH INTENSITY SCOTCHLITE)
19mm HIGH DENSITY OVERLAY FIR PLYWOOD

INK: 810 TRANSPARENT BROWN 3M

COLOR: TRANSPARENT BROWN ON SILVER BACKGROUND

LETTER STYLE: HELVETICA MEDIUM OR CLEAR VIEW FONT - SIZES AS SHOWN ABOVE

NOTES: LETTER SPACING TO BE DETERMINED WHEN EACH SIGN IS FABRICATED

**ALL DIMENSIONS
IN CENTIMETRES UNLESS
OTHERWISE NOTED**

**ARTERIAL ROAD PROJECT SIGN
DEVELOPER-BUILT PROJECTS**



STANDARD DRAWING

DATE APPROVED: **2018**

DRAWN BY: **KSYC**

APPROVED: *M.R.*

DRAWING NUMBER: **6520**

SCALE: **N.T.S.**

CHECKED BY: **JN**

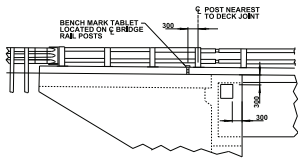

PLAQUE AND BENCH MARK TABLE LOCATION FOR MAJOR BRIDGE 1.30

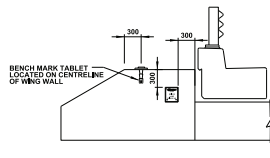

CONCRETE WINGWALL 1.30

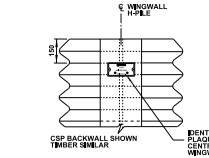

TIMBER OR CORRUGATED BACKWALL (CSP BACKWALL SHOWN TIMBER SIMILAR) 1.30

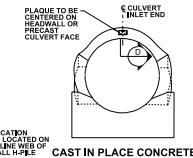

CAST IN PLACE CONCRETE HEADWALLS AND PRECAST CULVERTS (CSP SHOWN, PRECAST SIMILAR) N.T.S.

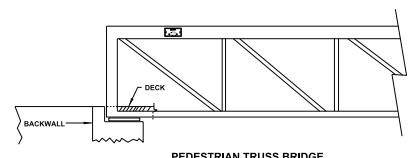

PEDESTRIAN TRUSS BRIDGE

PLAQUE AND BENCH MARK TABLE LOCATION FOR STANDARD BRIDGE/CULVERTS/PEDESTRIAN TRUSS BRIDGES

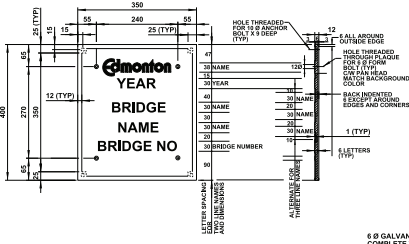

CASTING DETAILS 1.3

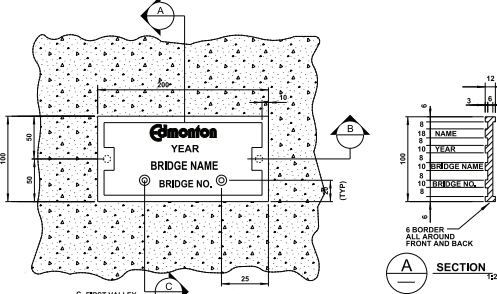

INSTALLATION DETAILS (CSP AND SP CSP CULVERTS) 1.3

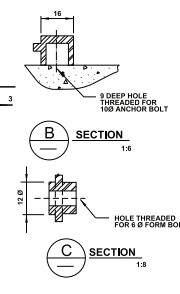

CASTING DETAILS 1.3

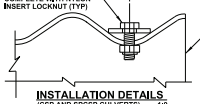

INSTALLATION DETAILS (CSP AND SP CSP CULVERTS) 1.3

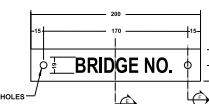

CASTING DETAILS 1.3

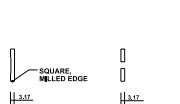

INSTALLATION DETAILS (CSP AND SP CSP CULVERTS) 1.3

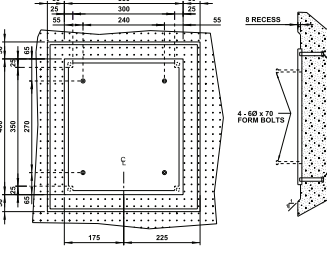

INSTALLATION DETAILS LARGE PLAQUE 1.3

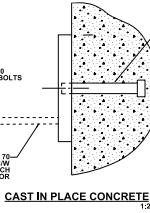

INSTALLATION DETAILS SMALL PLAQUE 1.3

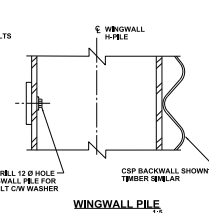

CASTING DETAILS WINGWALL PILE 1.3

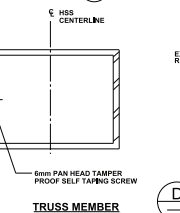

INSTALLATION DETAILS TRUSS MEMBER 1.3

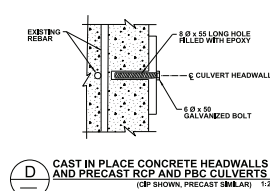

CASTING DETAILS CAST IN PLACE CONCRETE HEADWALLS AND PRECAST RCP AND PVC CULVERTS (CSP SHOWN, PRECAST SIMILAR) 1.3

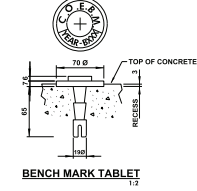

CASTING DETAILS BENCH MARK TABLE 1.3

GENERAL NOTES:

- ALL DIMENSIONS ARE IN MILLIMETERS UNLESS NOTED
- LARGE PLAQUE SHALL BE USED FOR VERTICAL BRIDGES, BRIDGE SIZE CULVERTS AND MAJOR PEDESTRIAN BRIDGES
- SMALL PLAQUE SHALL BE USED FOR STANDARD BRIDGES, CULVERTS, AND PEDESTRIAN TRUSS BRIDGES
- CULVERT PLAQUE SHALL BE USED FOR METAL CULVERTS
- FABRICATION AND INSTALLATION OF ALL PLAQUES AND BENCH MARK TABLES FOR ALL THE NEW STRUCTURES SHALL BE IN ACCORDANCE WITH STANDARD SPECIFICATIONS FOR BRIDGE CONSTRUCTION SECTION 13
- MATERIALS FOR ALL PLAQUES SHALL BE CAST ALUMINUM

PLAQUES:

- ALL PLAQUES SHALL BE FABRICATED TO THE DIMENSIONS SHOWN. ANY PROPOSED CHANGES SHALL BE APPROVED BY THE CITY OF EDMONTON
- BRIDGE PLAQUES SHALL BE LOCATED ON THE RIGHT HAND SIDE OF THE FIRST ABUTMENT ENCOUNTERED IN THE DIRECTION OF TRAVEL
- FOR RCP HEADWALLS AND PRECAST CONCRETE CULVERTS THE PLAQUE SHALL BE LOCATED AT THE INLET END
- ALL LETTERS AND NUMBERS CAST ON THE PLAQUE SHALL BE UPPERCASE UNIFORMS 66, EXCEPT NAME "EDMONTON"
- NAME "EDMONTON" SHALL BE FOLLOWED IN ABSOLUTE DETAILS AS SHOWN IN THE PRELO SEMIBOLD FONT. ANY DEVIATIONS REQUIRED FOR CASTING PURPOSES SHALL BE REVIEWED AND ACCEPTED BY THE CITY OF EDMONTON
- BRIDGE NAME CAST ON THE PLAQUES @ SITE SPECIFIC AND SHALL BE PROVIDED BY THE CITY OF EDMONTON
- THE BRIDGE NAME SHALL BE PLACED IN 2 OR 3 LINES AS REQUIRED
- THE YEAR SHALL BE THE YEAR WHEN CONSTRUCTION IS COMPLETED
- BRIDGE NUMBER SHALL BE OBTAINED FROM THE CITY OF EDMONTON
- ALL PLAQUES SHALL BE SUPPLIED WITH BLACK ANTI-OXIDANT PAINT EVERYWHERE EXCEPT FOR FULL BORDERS AND ALL NUMBERS AND LETTERS WHICH SHALL BE EXPOSED ALUMINUM WITH 2 LAYERS OF CLEAR COAT AND
- HEX HEAD CAP SCREWS SHALL CONFORM TO ASTM A307. NUTS AND WASHERS SHALL CONFORM TO ASTM A563 AND FINISH RESPECTIVELY
- BOLTS, NUTS AND WASHERS SHALL BE GALVANNEKED IN ACCORDANCE WITH ASTM F2329
- FILL MATERIAL THAT RECEIVE FORM BOLDS WITH EPOXY

BENCH MARK TABLES

- BRONZE BENCH MARK TABLES SHALL BE INSTALLED ON MAJOR AND STANDARD BRIDGE STRUCTURES
- THE SUPPLY, FABRICATION AND INSTALLATION OF BENCH MARK TABLES SHALL BE IN ACCORDANCE WITH CURRENT ALBERTA TRANSPORTATION STANDARD SPECIFICATIONS FOR BRIDGE CONSTRUCTION SECTION 13
- BENCH MARK TABLES SHALL BE INSTALLED ON ABUTMENTS THAT ARE SUPPORTED ON PILES OR BERTHOCS
- BENCH MARK TABLES SHALL GENERALLY BE PLACED ON THE NORTH WEST CORNER OF THE ABUTMENT AND THE LOCATION OF THE BENCH MARK TABLES SHALL BE CLEARLY MARKED ON THE SITE SPECIFIC DRAWINGS
- THE FINAL BENCH MARK ELEVATION AS WELL AS WHICH GEODETIC BASED BENCH MARK IT WAS TIED TO, WILL BE REPORTED TO THE CITY OF EDMONTON BRIDGE TEAM
- TWIN STRUCTURES WILL ONLY REQUIRE ONE BENCH MARK TABLE ON ONE OF THE STRUCTURES

				BRIDGE/CULVERT STANDARD IDENTIFICATION PLAQUES AND BENCHMARK TABLES	
DATE APPROVED	2023	DESIGNED BY	CJC	PROJECT	PROJ#
SCALE	N.T.S.	CHECKED BY	MS	DATE	
					6525

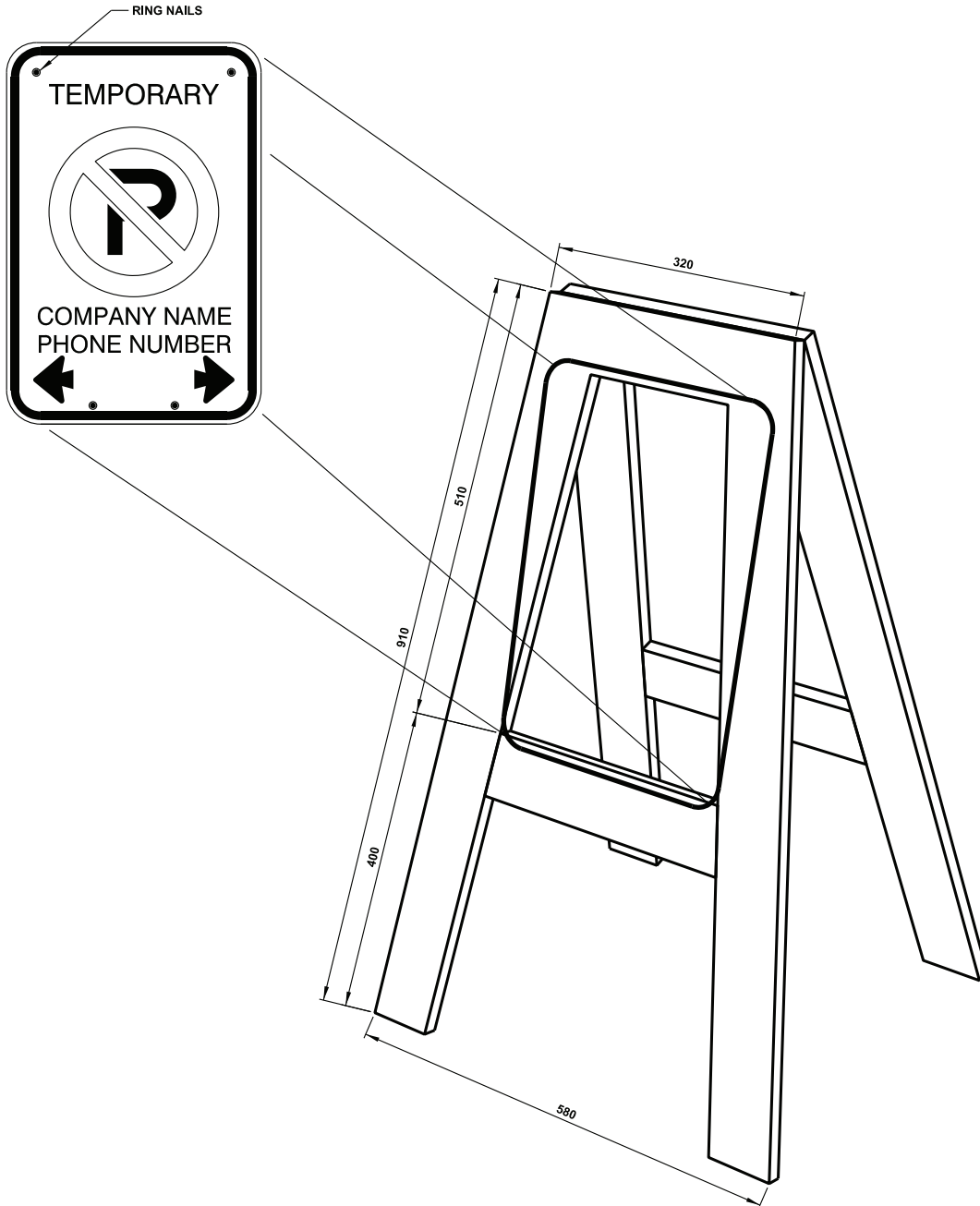

NOTES:

- 1. SIGN: 30cm x 45cm BLACK MESSAGE
BORDER: RED CIRCLE AND WHITE BACKGROUND. (RB-5203)
- 2. PLACE AT 45° FACING TRAFFIC.
SPACING @ 25.00m (MAX.)

**ALL DIMENSIONS
IN MILLIMETRES UNLESS
OTHERWISE NOTED**

TYPICAL A-FRAME SIGN



STANDARD DRAWING

DATE APPROVED: 2018

DRAWN BY: KSYC

APPROVED: *M.A.R.*

DRAWING NUMBER: 6530

SCALE: N.T.S.

CHECKED BY: JN

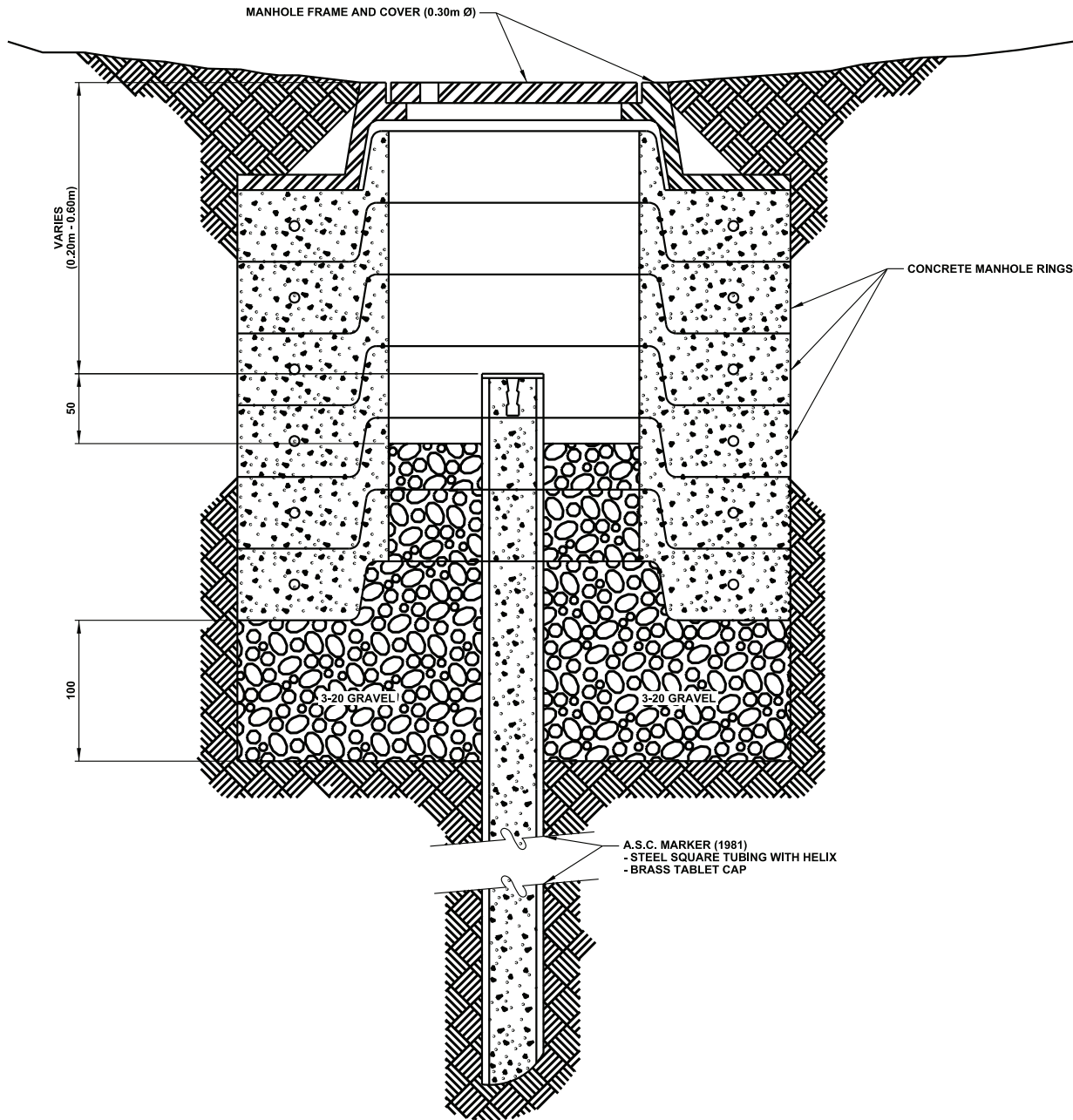

NOTES:

1. NUMBER OF CONCRETE RINGS (MINIMUM 4 RINGS) VARIES WITH DEPTH.

**ALL DIMENSIONS
 IN MILLIMETRES UNLESS
 OTHERWISE NOTED**



STANDARD DRAWING

**MANHOLE INSTALLATION FOR SURVEY CONTROL MARKERS
 DEPTHS BETWEEN 0.20m - 0.60m**

DATE APPROVED: **2018**

DRAWN BY: **KSYC**

APPROVED: *M.L.R.*

DRAWING NUMBER: **6600**

SCALE: **N.T.S.**

CHECKED BY: **JN**

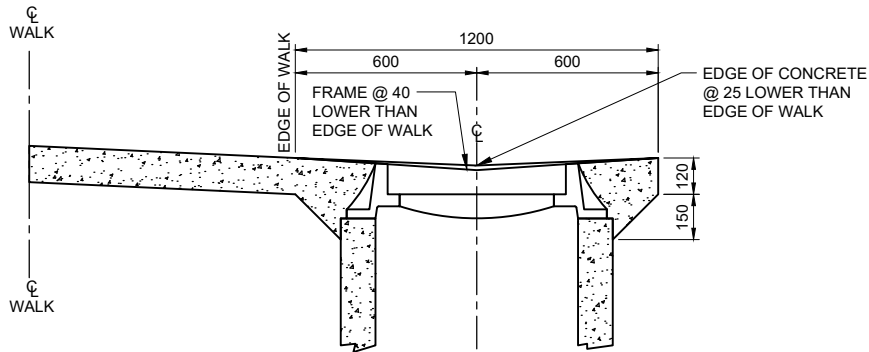
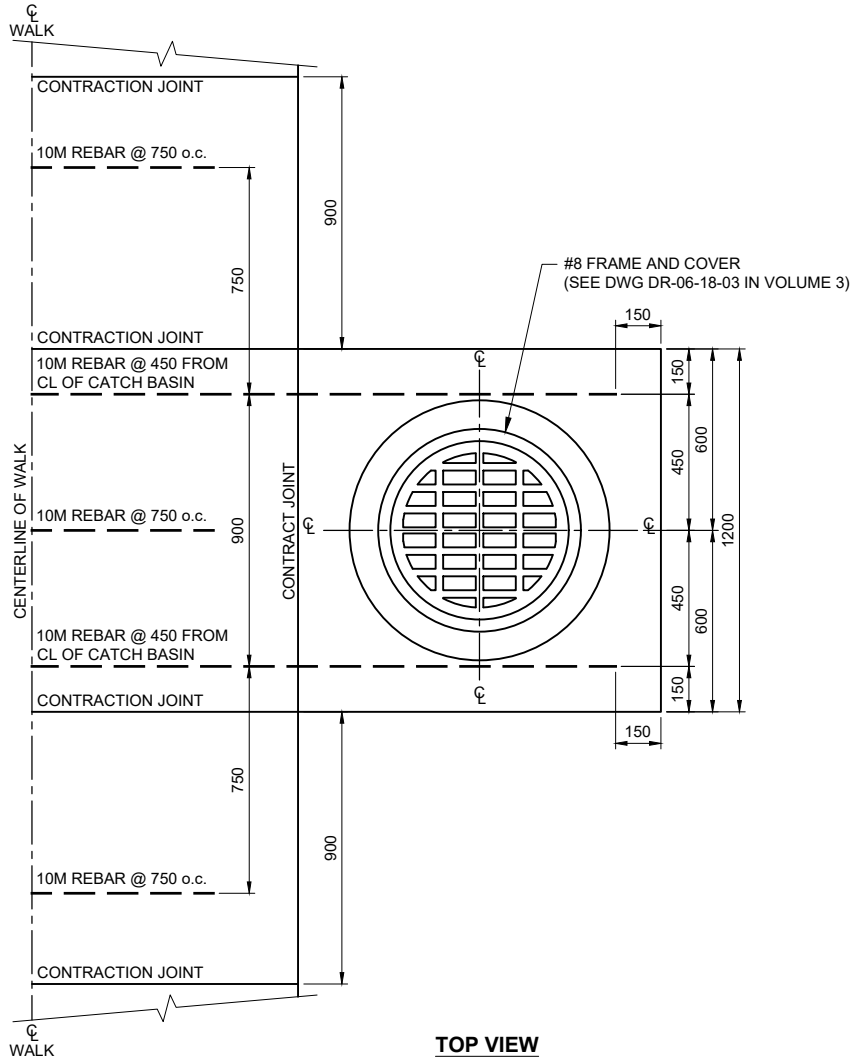

**ALL DIMENSIONS
IN MILLIMETRES UNLESS
OTHERWISE NOTED**

STANDARD DRAWING

CATCH BASINS IN WALKWAY RIGHT-OF-WAY

DATE APPROVED: **2025**
SCALE: **N.T.S.**

DRAWN BY: **FR**
CHECKED BY: **JN**

APPROVED: *[Signature]*

DRAWING NUMBER: **7976**

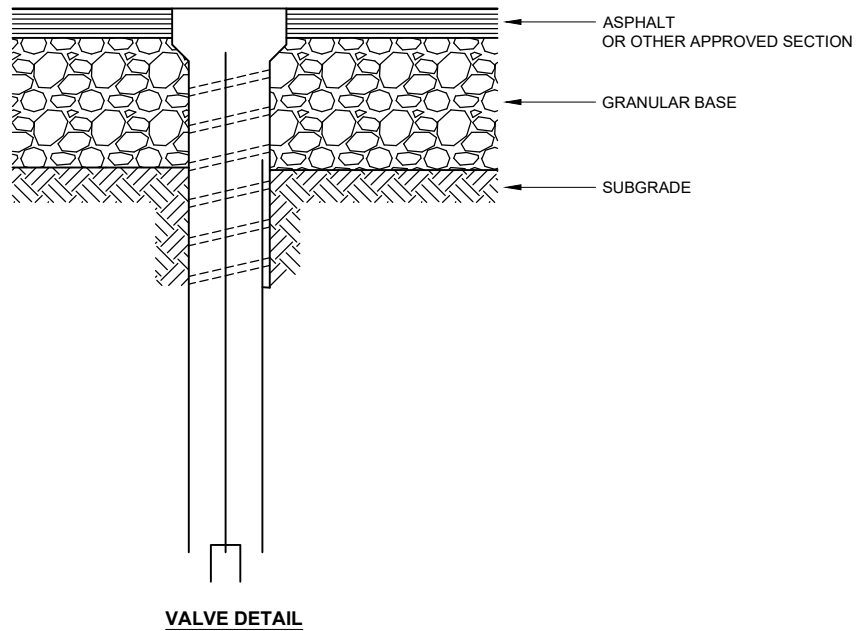
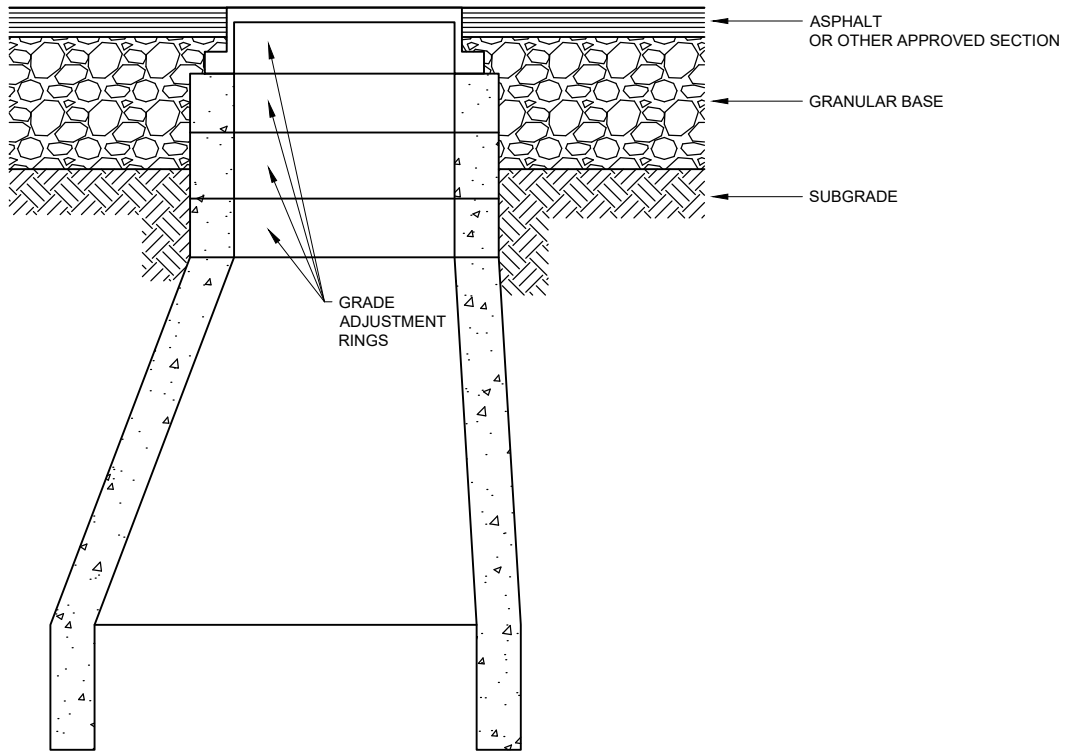

NOTE:

1. THIS DETAIL APPLIES TO BACKFILL FOR MAINTENANCE HOLE AND VALVE RAISED TO FINISH SUBGRADE, FINISHED GRAVEL GRADE, AND FINISHED ASPHALT GRADE IN SUCCESSIVE OPERATIONS.
2. BACKFILL WITH EXISTING MATERIALS (CLAY OR GRANULAR BASE) WHEN MAINTENANCE HOLE FRAMES AND COVERS ARE RAISED FROM BELOW SUBGRADE TO TOP OF SUCCESSIVE LAYER (SEVERAL OPERATIONS. IF NOT, REFER TO DRAWING #7981



STANDARD DRAWING

BACKFILL DETAIL OF MAINTENANCE HOLE AND VALVE RAISED TO GRADE

DATE APPROVED: **2025**

DRAWN BY: **FR**

APPROVED:

DRAWING NUMBER: **7980**

SCALE: **N.T.S.**

CHECKED BY: **JN**

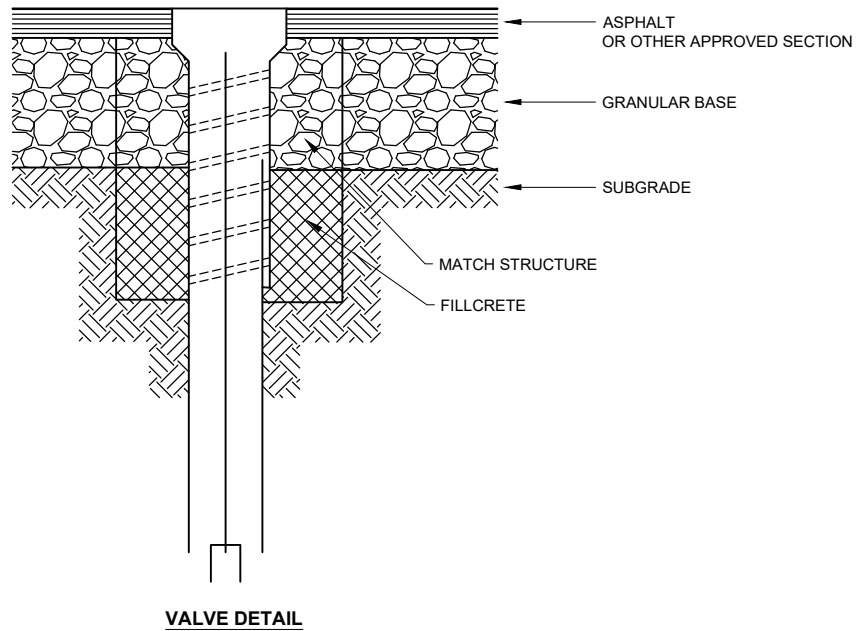
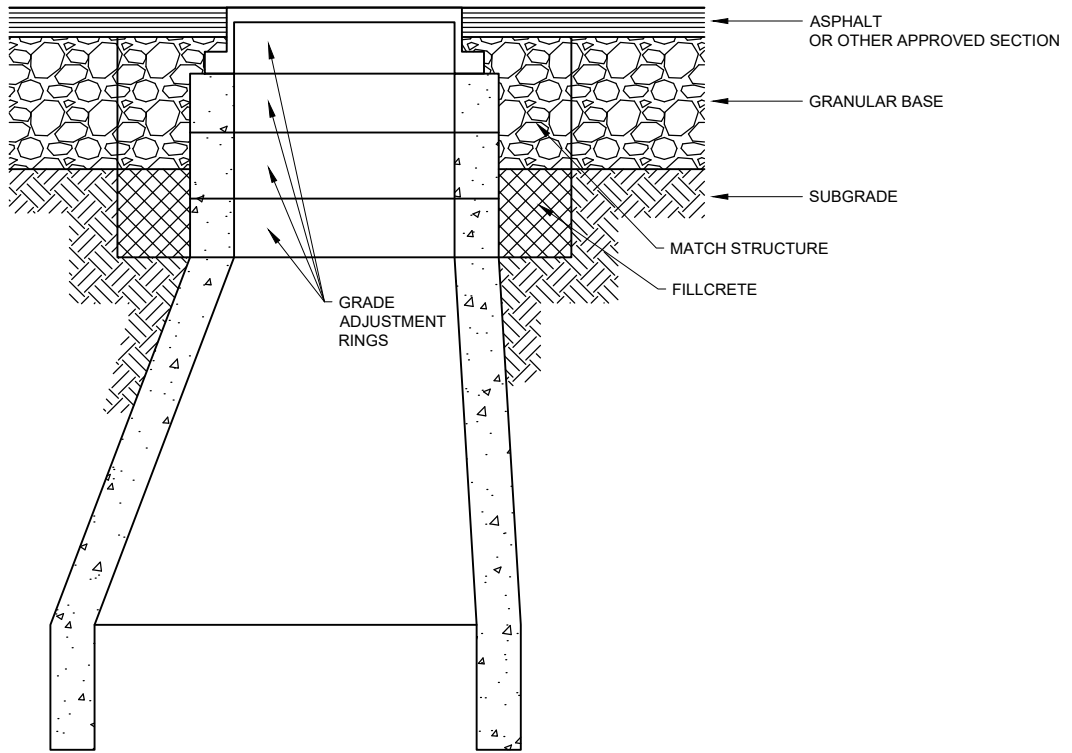

NOTE:

1. BACKFILL WITH FILLCRETE WHEN MAINTENANCE HOLE FRAMES AND COVERS ARE RAISED FROM BELOW SUBGRADE TO UNDERSIDE OF GRANULAR BASE.
2. SDR3T PVC SLEEVE TO BE PLACED AROUND VALVE CASING WHEN IN FILLCRETE.



STANDARD DRAWING

**BACKFILL DETAIL OF
MAINTENANCE HOLE AND VALVE RAISED TO GRADE (FILLCRETE OPTION)**

DATE APPROVED: **2025**

DRAWN BY: **FR**

APPROVED:

DRAWING NUMBER: **7981**

SCALE: **N.T.S.**

CHECKED BY: **JN**

